

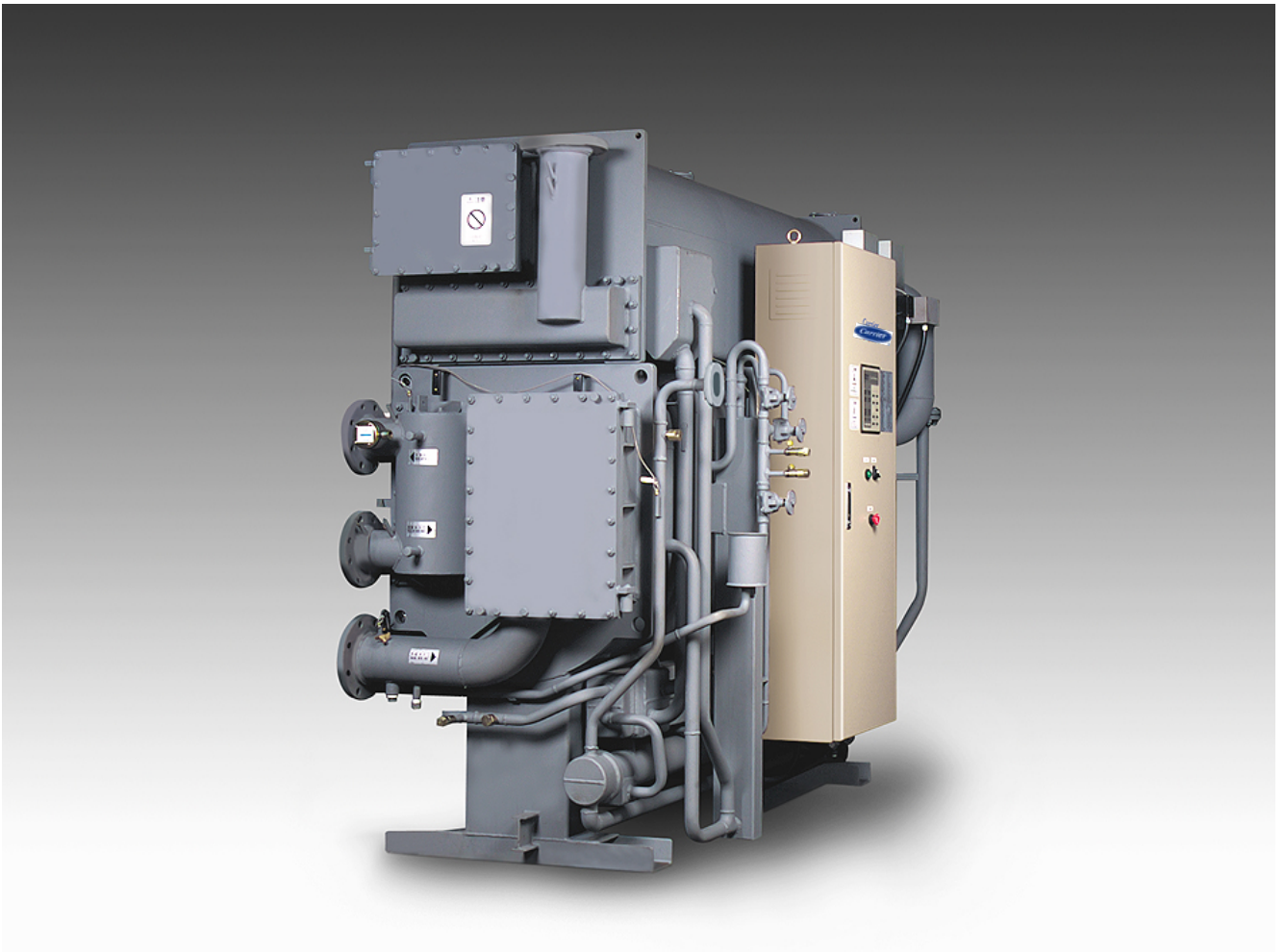

**INSTALLATION MANUAL**  
**Absorption Chiller**  
**16LJ-F Series**

---



*Original language*  
ACQA36-00270

## NOTES TO USERS

Thank you for purchasing Carrier Absorption Chiller.  
Before operating the Chiller, please read this manual thoroughly.

Please utilize the Chiller to its optimum performance by following recommended daily maintenance and handling, and periodic service.

If you need any information about maintenance contract or any other inquiries, please contact Carrier service agent.

## DECLARATION OF CONFORMITY < for CE marking model >

This product is marked " CE " as it satisfied EEC Directive No. 2006/42/EC, 2014/30/EU, 97/23/EC, 2009/142/EC and conforms with following standards.

This declaration will become void in case of misuse and/or from non observance though partial of Manufacturer's installation and/or operating instructions.

Class and group description (EN 55011, clause 5.1)

This is group 1, class A product according to EN 55011. This means that this product does not generate and/or use intentionally radio-frequency energy, in the form of electromagnetic radiation, inductive and/or capacitive coupling, for the treatment of material or inspection / analysis purpose and that it is suitable for use in all establishments other than domestic and those directly connected to a low voltage power supply network which supplies buildings used for domestic purposes.

Statement for Class A Equipment (EN 55011, clause 5.3)

This is a class A product. There may be potential difficulties in ensuring electromagnetic compatibility in environments other than industrial, due to conducted as well as radiated disturbances.

Cable Specification and Equipment Orientation (EN 55011, clause 7.5.2 and EN 61000-6-2)

Refer to the "Field wiring" section of the Installation manual.

CE Marking and Apparatus Identification (2006/42/EC, clause 16.2 and 2004/108/EC, clause 8.1)

There are printed on the nameplate of the chiller control panel.

Name and Address of Manufacture

Refer to the document of Declaration of conformity.

Statement for Equipment for with Compliance with the Protection Requirements is not ensured in Residential Areas (EMC Directive 2014/30/EU, clause 9.4)

- This product must not be used in residential areas.
- This product may cause interference if used in residential areas. Such use must be avoided unless the user takes special measures to reduce electromagnetic emissions to prevent interference to the reception of radio and television broadcasts.

## UL CERTIFICATION < for UL marking model >

This product has met the necessary design and construction qualifications for certification per Underwriters' Laboratories. Each machine carries a UL listing and is labeled accordingly.

## PRODUCT PROFILE

- (1) Excellent for peak shaving during high electrical demand periods.
- (2) Designed to provide chilled water from waste heat sources, generated from industrial processes and cogeneration systems.
- (3) Allows diversification of critical cooling requirements. Critical cooling loads are met with minimal electrical power input with a hot water-fired chiller.
- (4) Allows for smaller generator set installation be utilized since the electrical load associated with an absorption chiller is minimal when compared to an electric chiller.
- (5) Ozone safe, CFC free. Cooling requirements are met without chlorine based refrigerants.
- (6) Reduces effectors to global warming. Minimizes global impact by greatly reducing electricity consumption and eliminating the use of greenhouse gases.
- (7) Environment: Molybdate solution inhibitor is used with no impact on environment.
- (8) Low noise and vibration. The absorption chiller dose not utilize a large motor-compressor, and this leads to quiet, trouble-free operation.
- (9) Small footprint saves facility space.

## USE OF PRODUCT

Absorption Chiller is air conditioning equipment achieving comfortable space, energy saving, and economic efficiency. It has been used in office buildings, hotels, department stores, hospitals, schools, convention centers, government building, etc.



Note: The contents of this manual are subject to change without notice.

Table of Contents

1. Safety Precautions -----	1
2. Installation	
2-1. Installation plan -----	3
2-2. Rigging work and safety precautions -----	3
2-3. Carrying-in with rolling work -----	4
2-4. Procedure and note for horizontal pulling installation -----	4
2-5. Installation location -----	4
2-6. Installation space -----	4
2-7. Safety precautions at the installation on the foundation -----	5
3. Requirements for the foundation	
3-1. Foundation work -----	5
3-2. Accuracy of dimensions and levelness of the foundation -----	5
3-3. Foundation bolts -----	6
4. Piping -----	6
5. Field wiring -----	6
6. External visual inspection -----	6







# 1. Safety precautions

Be sure to follow the instructions and requirements on safety described in this manual. We explain about a harm or damage if a chiller is used with mistaken usage ignoring these precautions.

	<b>WARNING</b>	Failure to observe this instruction may cause serious injury or death.
	<b>CAUTION</b>	Failure to observe this instruction may result in impediment or damage to the product or the property.







## Symbol conventions

 Refer to advice that must be observed.

 <b>WARNING</b>	
<p><b>Leave the installation work to professionals</b></p> <p>Leave the installation work to professionals. Inadequate work may cause a water leakage, shock, fire, etc.</p> <div style="text-align: right;">   <b>Must be observed</b> </div>	<p><b>Rigging and moving of the unit shall be done by the licensed professionals</b></p> <p>Rigging and moving of the unit shall be done by the licensed professionals following the manufacturer's instructions. Inappropriate operation may cause accidents such as turnover, falling, etc.</p> <div style="text-align: right;">   <b>Must be observed</b> </div>
<p><b>Unit shall be firmly fixed</b></p> <p>Unit shall be firmly fixed by bolts/nuts on the foundation which has adequate strength to carry the system. Strength poverty or fixing defect may cause a water leakage and/or turnover of the unit in case.</p> <div style="text-align: right;">   <b>Must be observed</b> </div>	<p><b>The installation location shall be free from flammable circumstances</b></p> <p>The installation location shall be free from flammable circumstances and/or corrosive gases otherwise it may cause fire.</p> <div style="text-align: right;">   <b>Must be observed</b> </div>
<p><b>Follow the applicable codes and chiller specifications</b></p> <p>Follow the applicable codes and chiller specifications. Inadequate wiring capacity or defective works may cause shock, fire, etc.</p> <div style="text-align: right;">   <b>Must be observed</b> </div>	



## CAUTION

<p><b>The machine room shall be finished with waterproof floor</b></p> <p>The machine room shall be finished with waterproof floor to protect surrounding equipments and facilities from wetting.</p> <p> <b>Must be observed</b></p>	<p><b>Ventilate the machine room whenever nitrogen pressurized test is performed</b></p> <p>Fully ventilate the machine room whenever nitrogen pressurized test is performed on the unit or piping. Insufficient ventilation may cause an oxygen-deficient accident.</p> <p> <b>Must be observed</b></p>
<p><b>Make space around the unit for safe maintenance work</b></p> <p>Make space around the unit for safe maintenance work. Lack of space may cause deficient service works and an injury in case.</p> <p> <b>Must be observed</b></p>	<p><b>Earth leakage breaker shall be installed</b></p> <p>Earth leakage breaker shall be installed in some installation locations to prevent a shock accident.</p> <p> <b>Must be observed</b></p>
<p><b>Perform grounding works</b></p> <p>Grounding works is necessary but never connect the earth wire to the gas piping, water piping and/or earth line of the lightning rod or telephone. Imperfect grounding may damage the unit or cause a shock.</p> <p> <b>Must be observed</b></p>	<p><b>Wires shall be securely connected</b></p> <p>Wires shall be securely connected and the terminal connection shall be stress-free from any external force. Defective connection may cause heat generation or fire.</p> <p> <b>Must be observed</b></p>
<p><b>Flue and the unit shall be insulated by professionals</b></p> <p>Flue and the unit shall be insulated by professionals. Insufficient insulation may cause a fire or a burn injury.</p> <p> <b>Must be observed</b></p>	

### NOTE)

- (1) Absorption chiller is indoor use only.
- (2) IP number of Absorption chiller is IP40.
- (3) Install Absorption chiller at a height of less than 1000m above sea level. If the location is higher than 1000m above sea level, please contact a service agent.

## 2. Installation

### 2-1. Installation plan

It is very important to make an installation plan of the absorption chiller because it is relatively large machinery in the air-conditioning system. The construction form of the air-conditioning system is on-site assembly of the various equipments therefore it is necessary to set a strict schedule to enable a timely installation of every required element depending on the status of progress of the construction work. Regarding the installation of the absorption chiller, its style of packing, installation date and hour, carrying-in route, installation method, etc. are closely related to the local road conditions and the construction site conditions, therefore it is necessary to make preliminary arrangements with the relevant parties.

A basic term of delivery is FOB shipping point. Unloading, horizontal pulling and setting are scope of supply for the purchaser.

### 2-2. Rigging work and safety precautions

- (1) Only the licensee shall perform the rigging work.
- (2) Confirm the Load and center of gravity on the specification.
- (3) Rigging wire and shackle shall meet the local rule.
- (4) Sling angle shall be within 60 degree.
- (5) Four-point suspension is essential. Two-point suspension or slant suspension is absolutely forbidden.
- (6) When the wire hits against any piping or element, protect it with a guard plate.
- (7) Basically the unit is a high vacuum vessel charged with absorbent solution and refrigerant. It is possible that a vacuum breaking damage may cause irremediable harm to the unit. Particular attention should be given to the bottom area where the bottom shell, piping, pumps exist.

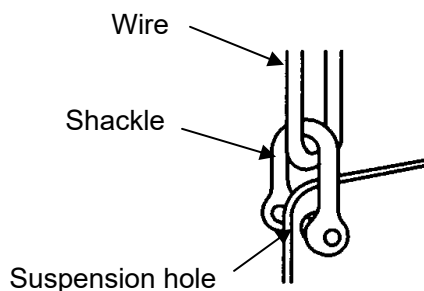

Suspension hole diameter

LJ-F11 true 53 : 42 mm (1-5/8 inch)

LJ-F61 true 63 : 50 mm (2 inch)

LJ-F71 true 73 : 60 mm (2-3/8 inch)

LJ-F81 true 82 : 72 mm (2-7/8 inch)

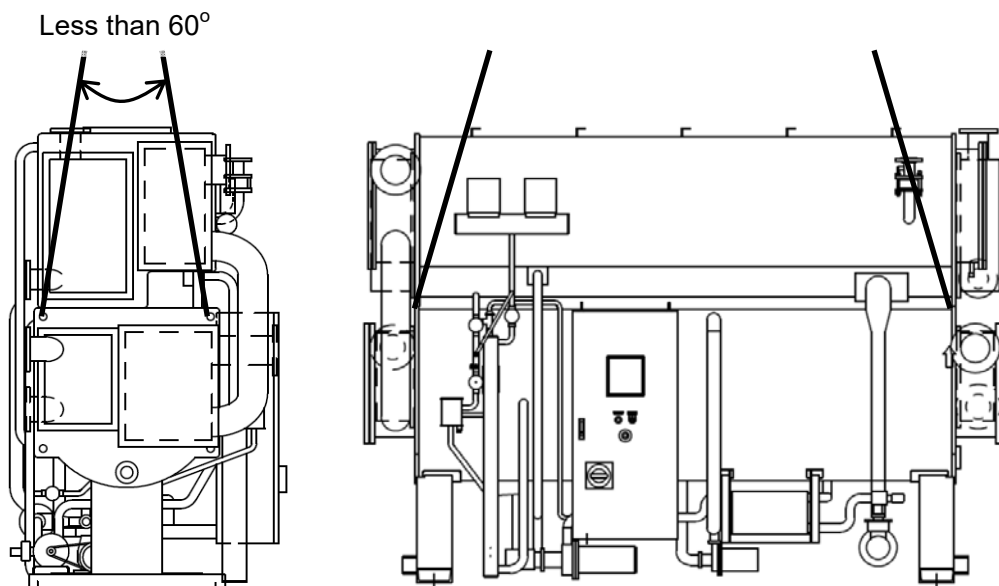

### 2-3. Carrying-in with rolling work

Size of the equipment hatch and the carrying-in entrance shall exceed the overall dimension which is indicated on the specification. If the unit is rolled on logs, size of the rolls and soleplate shall be considered.

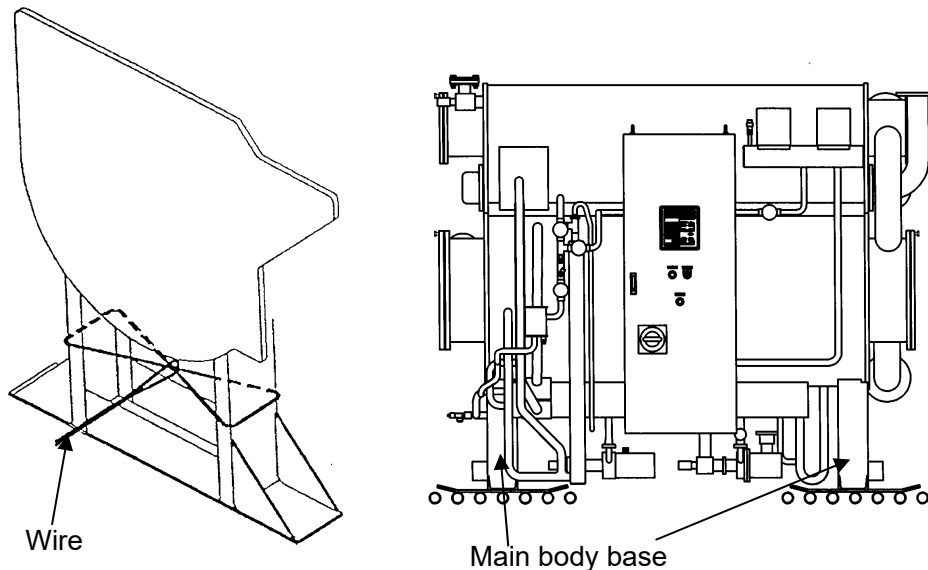

The rolls and soleplate shall be set underneath the base of the main body as shown by the diagram.

#### Note

- \*The above procedures shall also be applied to the multi section shipping unit.
- \*Unit appearance at the installation varies by model.

### 2-4. Procedure and note for horizontal pulling installation

The pulling wire should be connected to the base of the main unit as shown by the diagram. Pull the unit gently. If the ground or floor is inclined the unit shall be pulled ahead and behind.

### 2-5. Installation location

- (1) Set the chiller on a firm and flat floor.
- (2) The installation location should be free from corrosive gas, dust and high-humidity.

### 2-6. Installation space

Ensure the space based on the external dimensions in the contract specification.

- (1) Tube removal space  
To enable the replacement of the all heat transfer tubes, the space must be secured at either end in a longitudinal direction of the chiller. Refer to the detail data on the "Dimensions" in the specification. Temporary transfer of the obstacles is a choice to make the space at the case may be.
- (2) Maintenance space  
At least 0.5m (2feet)-wide maintenance space is required around the unit. Also the maintenance space for the facility equipment such as valves and instruments should be considered.
- (3) Upper clearance of the unit  
At least 0.4m (16 inch) is required.

## 2-7. Safety precautions at the installation on the foundation

Put the chiller on the foundation slowly and gently with careful attention to the foundation bolts positions. Also pay attention to avoid falling or turnover accident.

## 3. Requirements for the foundation

Refer to the information on the foundation as shown in the contract specifications. Set the chiller on the foundation bolt position.

### 3-1. Foundation work

- (1) The concrete foundation should be finished in consideration of the required level for the chiller.
- (2) The foundation shall meet the loads bearing requirements and also avoid trouble of a differential settlement between the main body and the high temp. generator.
- (3) Prevention against noise and vibration should be taken into consideration.

### 3-2. Accuracy of dimensions and levelness of the foundation

Important precaution for the foundation dimensions are flatness of each foundation and levelness error between two foundations parted in a longitudinal direction of the chiller.

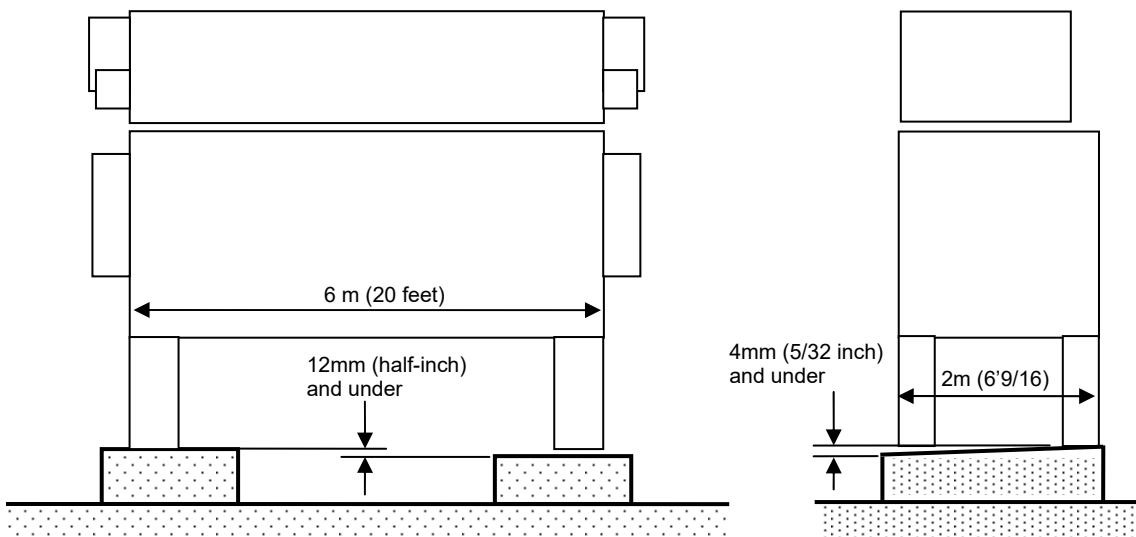

Permissible levelness for the absorption chiller installation

The permissible levelness for the absorption chiller is 2/1000 in both longitudinal and width direction. For the 6 meter(20 feet)-long absorption chiller the error should be 12mm(half-inch) and under in longitudinal direction, and for 2 meter(6'9/16")-wide unit it should be 4mm(5/32 inch) and under in width direction.

Cement mortar finish is not required for the foundation surface but trowelled finishing of the concrete should be performed in consideration of the above levelness.

### 3-3. Foundation bolts

Foundation bolts, washers and nuts are the scope of supply for purchaser.

- (1) Weld the washers on the chiller's frame.
- (2) Tight up the nuts.

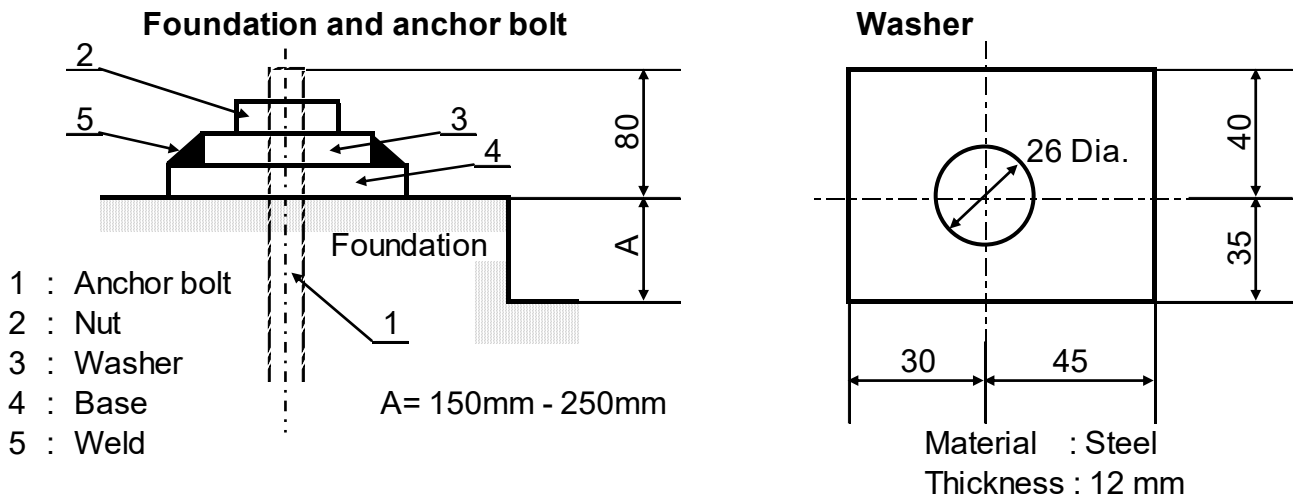

## 4. Piping

### 4-1. Piping

- (1) Connect each pipe according to "Typical piping diagram" and "Rupture disk" in the contract specifications.
- (2) Make all necessary connections to the building water and steam systems. Ensure that all piping is adequately supported and that no strain is placed on the Chiller nozzles and connecting flanges.
- (3) Provide adequate temperature sensing and pressure sensing sockets or taps on all the supply and return piping.

### 4-2. Flashing

It is necessary to flash in the pipe of all water system before running water through the chiller.

## 5. Field wiring

- (1) For CE marking; Power supply connection shall follow the overvoltage category III. And other connections shall follow the overvoltage category II. Connect each wire according to CE requiring.
- (2) Refer to "Field electric wiring" and "Electric wiring diagram" in the contract specifications for wiring connection.
- (3) A properly qualified electrician should carry out the electrical wiring works.

## 6. External visual inspection

The followings shall be inspected.

- (1) Insulation for the Chiller shall be properly performed.
  - a) Each valves, dampers, service valves and sight glass shall be operable.
  - b) Temperature sensors and pressure gauges shall be replaceable.
  - c) Ber- thermometers shall be able to insert into holders provided on water headers and solution pipes.
  - d) Each water header cover shall be removable.
  - e) The following parts shall not be insulated.
    - \*The motor portion of the refrigerant pump, \*Rupture disk

- (2) No-rust shall be observed on the Chiller.
- (3) No-looseness shall be observed at each flange and bolted connections.
- (4) No-looseness shall be observed at each Water header flange of the chiller.
- (5) There shall be no-liquid leakage from the Chiller.
- (6) No-damage shall be observed on all components of the Chiller.
- (7) There shall be no-missing of all components of the Chiller.
- (8) No-wire-cut shall be observed on electric wiring and piping.

---

Manufacturer  
CARRIER SCS  
Route de Thil - BP49  
01122 MONTLUEL CEDEX, FRANCE