

TOSHIBA

AIR CONDITIONER (MULTI TYPE)

Installation Manual

R32 or R410A

Indoor Unit

Model Name:

For commercial use

High-Wall Type

MMK-UP0051DHPL-E

MMK-UP0071DHPL-E

MMK-UP0091DHPL-E

MMK-UP0121DHPL-E

MMK-UP0151DHPL-E

MMK-UP0181DHPL-E

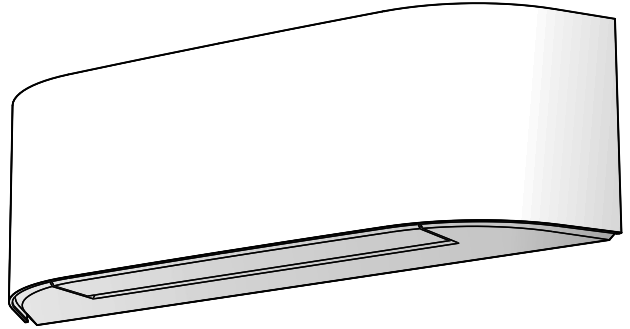

When the DHPL model (MMK-UP*DHPL-E) is installed, PMV kit is necessary

Scan QR CODE to access installation and owner's manual on website.

<https://www.toshiba-carrier.co.th/manuals/default.aspx>

Manual are available in AR/BG/CS/DA/DE/EL/EN/ES/ET/FI/FR/HR/HU/IT/LV/NL/NO/PL/PT/RO/RU/SK/SL/SV/TR.



Original instruction









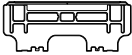
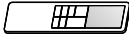

Please read this Installation Manual carefully before installing the Air Conditioner.

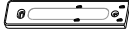
- This Manual describes the installation method of the indoor unit.
- For installation of the outdoor unit, follow the Installation Manual attached to the outdoor unit.

Contents

1	ACCESSORY PARTS	2
2	SELECTION OF INSTALLATION PLACE	4
3	INSTALLATION OF INDOOR UNIT	7
4	CUTTING A HOLE AND MOUNTING INSTALLATION PLATE	8
5	PIPING AND DRAIN HOSE INSTALLATION	10
6	INDOOR UNIT FIXING	14
7	DRAINAGE	15
8	REFRIGERANT PIPING	16
9	ELECTRICAL CONNECTION	18
10	APPLICABLE CONTROLS	27
11	TEST RUN	30
12	TROUBLESHOOTING	32
13	SPECIFICATIONS	38
14	NOTICE CODE	38
15	APPENDIX	41

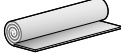
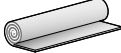
1 ACCESSORY PARTS

No.	Part name	Q'ty	Shape	Usage
①	Installation plate	1		-
②	Wireless remote controller	1		-
③	Battery	2		-
④	Remote controller holder	1		-
⑤	Ultra pure filter	2		-
⑥	Mounting screw	10		-
⑦	Flat head wood screw	2		-
⑧	Screw	2		-
⑨	Owner's Manual	1		For hand over to customers
⑩	Installation Manual	1		For hand over to customers
⑪	Decorative fabric (dark gray)	1		-
⑪	Decorative fabric (light gray)	1		-
⑫	Safety Manual	1		For hand over directly to the customer

■ Decorative Fabric Installation

The decorative fabric for cover on the air inlet grille of indoor unit was put in the accessories. User can use it as required.

The method of installation is as follows.

1. Remove the air inlet grille.
Open the air inlet grille upward and pull it toward you.
As shown on figure as below.

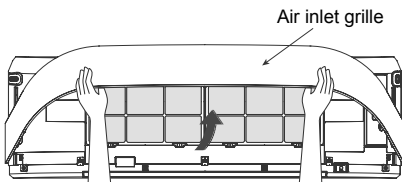

2. Prepare the fabric that you choose for install.
3. Insert the fabric into the left and right side of the air inlet grille and adjust corner position of decorative fabric is smooth.
Attach the hook and loop of velcro tape fully together.
As shown on figure as below.

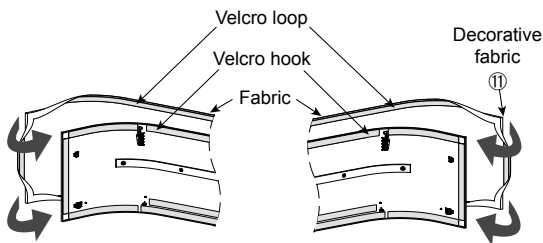

4. Insert the fabric into the top and bottom side of the air inlet grille.
Attach the hook and loop of velcro tape fully together.
As shown on figure as below.

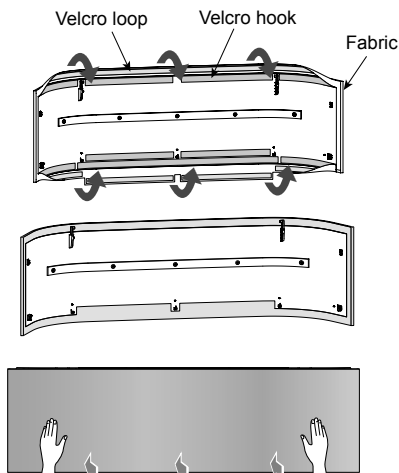

5. Reassembly the air inlet grille by reverse process of 1.

NOTE

- The tightness of the fabric depends on attaching the hook and loop of velcro around the air inlet grille, take appropriate action.

⚠ CAUTION

- If clean decorative fabric by washing, it may affect to appearance and fitting of the decorative fabric.
- Recommend to use vacuum cleaner to removing the dusts from decorative fabric.

2 SELECTION OF INSTALLATION PLACE

WARNING

- **Install the air conditioner at enough strong place to withstand the weight of the unit.**
If the strength is not enough, the unit may fall down resulting in injury.

CAUTION

- **Do not install in a location where flammable gas may leaks are possible.**
If the gas leak and accumulate around the unit, it may ignite and cause a fire.
- **When an outdoor unit using R32 refrigerant is combined with indoor unit, be attention to the floor area in the room to be installed.**
Indoor units cannot be installed in rooms with a floor area less than the minimum floor area.
For details, follow the Installation Manual to the outdoor unit.

Upon approval of the customer, install the air conditioner in a place that satisfies the following conditions.

- Place where the unit can be installed horizontally.
- Place where a sufficient servicing space can be ensured for safety maintenance and check.
- Place where drained water will not cause any problem.

Avoid installing in the following places.

Select a location for the indoor unit where the cool or warm air will circulate evenly.

Avoid installation in the following kinds of locations.

- Saline area (coastal area).
- Locations with acidic or alkaline atmospheres (such as areas with hot springs, factories where chemicals or pharmaceuticals are made and places where the exhaust air from combustion appliances will be sucked into the unit).
Doing so may cause the heat exchanger (its aluminum fins and copper pipes) and other parts to become corroded.
- Locations with atmospheres with mist of cutting oil or other types of machine oil.
Doing so may cause the heat exchanger to become corroded, mists caused by the blockage of the heat exchanger to be generated, the plastic parts to be damaged, the heat insulators to peel off, and other such problems to result.
- Places where iron or other metal dust is present. If iron or other metal dust adheres to or collects on the interior of the air conditioner, it may spontaneously combust and start a fire.
- Locations where vapors from food oils are formed (such as kitchens where food oils are used).
Blocked filters may cause the air conditioner's performance to deteriorate, condensation to form, the plastic parts to be damaged, and other such problems to result.
- Locations near obstructions such as ventilation openings or lighting fixtures where the flow of the blown air will be disrupted (a disruption of the air flow may cause the air conditioner's performance to deteriorate or the unit to shut down).
- Locations where an in-house power generator is used for the power supply.
The power line frequency and voltage may fluctuate, and the air conditioner may not work properly as a result.
- On truck cranes, ships or other moving conveyances.
- The air conditioner must not be used for special applications (such as for storing food, plants, precision instruments or art works).
(The quality of the items stored may be degraded.)
- Locations where high frequencies are generated (by inverter equipment, in-house power generators, medical equipment or communication equipment).
(Malfunctioning or control trouble in the air conditioner or noise may adversely affect the equipment's operation.)
- Locations where there is anything under the unit installed that would be compromised by wetness.
(If the drain has become blocked or when the humidity is over 80%, condensation from the indoor unit will drip, possibly causing damage to anything underneath.)
- In the case of the wireless type of system, rooms with the inverter type of fluorescent lighting or locations exposed to direct sunlight.
(The signals from the wireless remote controller may not be sensed.)
- Locations where organic solvents are being used.
- The air conditioner cannot be used for liquid carbonic acid cooling or in chemical plants.
- Location near doors or windows where the air conditioner may come into contact with high-temperature, high-humidity outdoor air.
(Condensation may occur as a result.)
- Locations where special sprays are used frequently.

■ Installation diagram of Indoor unit

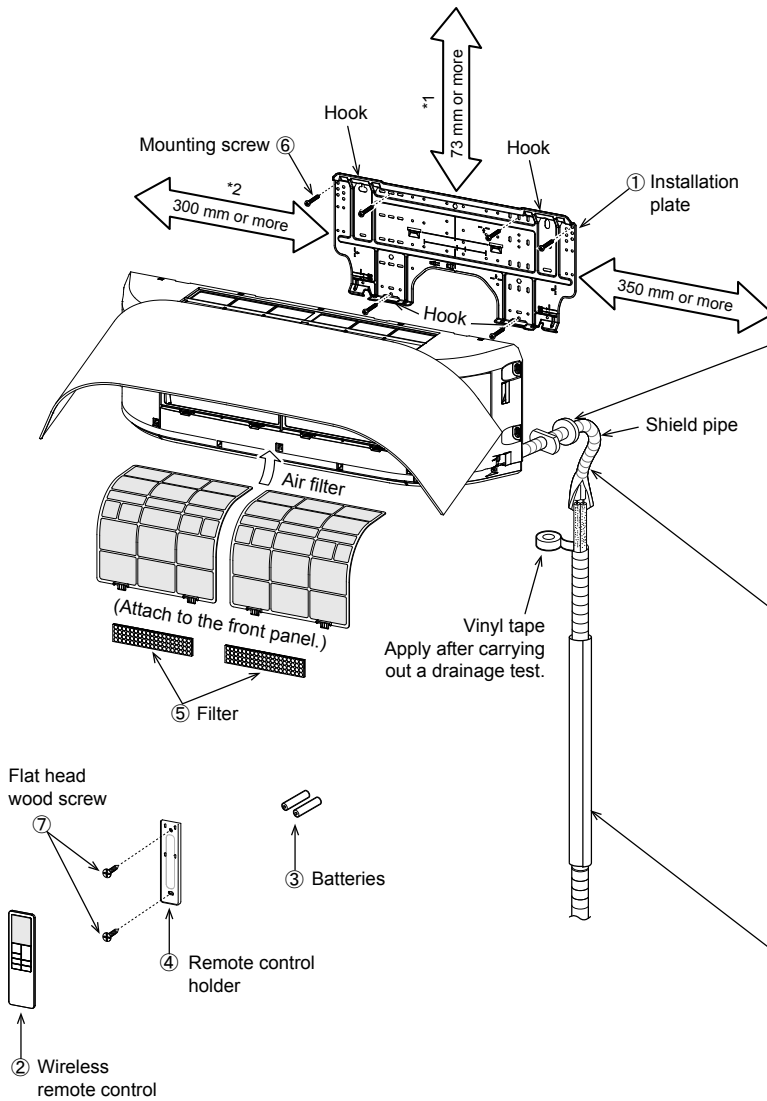

For the rear left and bottom left piping

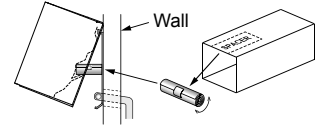

Cut out a piece of SPACER from indoor unit packaging box, roll it and insert between the indoor unit and wall to tilt the indoor unit for better operation.

The auxiliary piping can be connected to rear left, rear right, bottom right or bottom left.

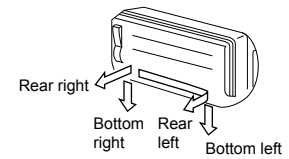

Do not allow the drain hose to get slack.

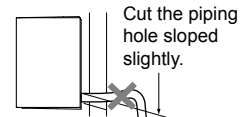

Make sure to run the drain hose sloped downward.

Refrigerant piping must be protected from physical damage. Install a plastic cover or equivalent.

Insulate the refrigerant pipes separately with insulation, not together.

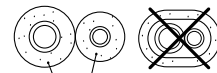

6 mm thick heat resisting polyethylene foam

■ Installation space

The indoor unit shall be installed at least 2.5 m height.

Also it must be avoided to put anything on top of the indoor unit.

*1 Reserve space required to install the indoor unit and for service work.

Keep 73 mm or more for clearance between top plate of the indoor unit and the ceiling surface.

*2 Provide a space as shown for service clearance for the cross flow fan.

■ Installation place

- A place which provides the spaces around the indoor unit as shown in the above diagram.
- A place where there is no obstacle near the air inlet and outlet.
- A place that allows easy installation of the piping to the outdoor unit.
- A place which allows the front panel to be opened.

⚠ CAUTION

- Direct sunlight to the indoor unit's wireless receiver should be avoided.
- The microprocessor in the indoor unit should not be too close to RF noise sources.
(For details, see the Owner's Manual.)

■ Wireless remote controller

- A place where there are no obstacles such as a curtain that may block the signal from the indoor unit.
- Do not install the remote controller in a place exposed to direct sunlight or close to a heating source, such as a stove.
- Keep the remote controller at least 1 m apart from the nearest TV set or stereo equipment.
(This is necessary to prevent image disturb-bounces or noise interference.)
- The location of the remote controller should be determined as shown below.

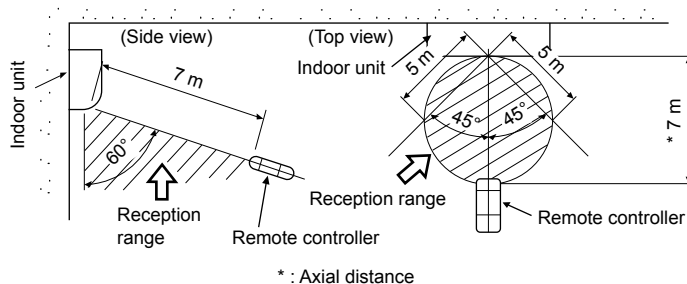

4 CUTTING A HOLE AND MOUNTING INSTALLATION PLATE

■ Cutting a hole

In case of installing the refrigerant pipes from the rear:

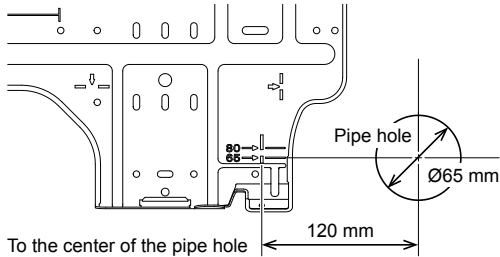

1. After determining the pipe hole position on the mounting plate (➔), drill the pipe hole (Ø65 mm) at a slight downward slant to the outdoor side.

NOTE

- When drilling a wall that contains a metal lath, wire lath or metal plate, be sure to use a pipe hole brim ring sold separately.

■ Mounting the installation plate

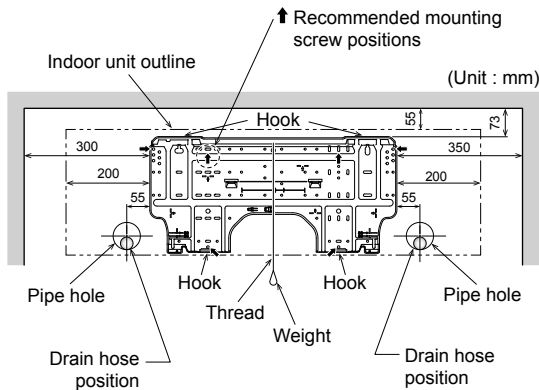

■ Space allows under the indoor unit

- Space allows for moving range of the air inlet grille and horizontal louver in operation above curtain rails, window cornice or other objects.

(Unit : mm)

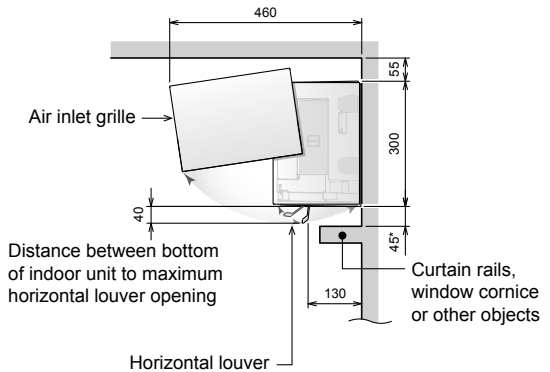

⚠ CAUTION

- If have curtain rails, window cornice or other objects, allow space from the indoor unit should be 45 mm or more.
- If allow space is less than 45 mm, this can affect the opening and closing of the air inlet grille and the horizontal louver.
- However, there should be no objects in the air outlet position. It will block the air flow direction and drop performance.

■ When the installation plate is directly mounted on the wall

1. Securely fit the installation plate onto the wall by screwing it in the upper and lower parts to hook up the indoor unit.
2. To mount the installation plate on a concrete wall with anchor bolts, utilize the anchor bolt holes as illustrated in the above figure.
3. Install the installation plate horizontally in the wall.

CAUTION

When installing the installation plate with a mounting screw, do not use the anchor bolt hole. Otherwise the unit may fall down and result in personal injury and property damage.

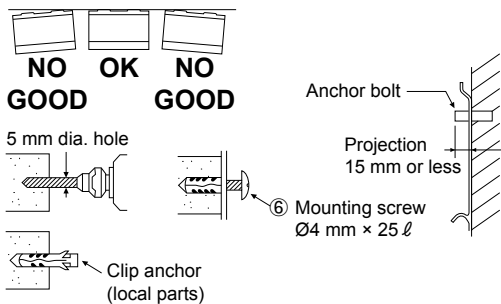

CAUTION

Failure to firmly install the unit may result in personal injury and property damage if the unit falls.

- In case of block, brick, concrete or similar type walls, make 5 mm dia. holes in the wall.
- Insert clip anchors for appropriate mounting screws.

NOTE

- Secure four corners and lower parts of the installation plate with 6 mounting screws to install it.

5 PIPING AND DRAIN HOSE INSTALLATION

■ Piping and drain hose forming

- Since dewing results in a machine trouble, make sure to insulate both connecting pipes. (Use polyethylene foam as insulating material.)
- The connection of pipes can be installed in the following directions.

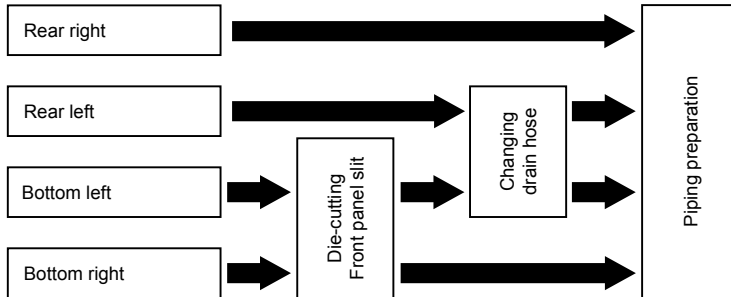

• Rear right

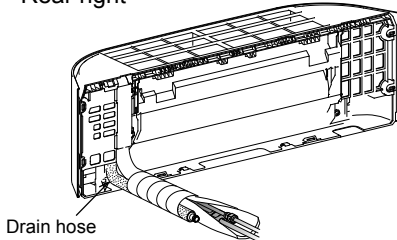

Drain hose

• Rear left

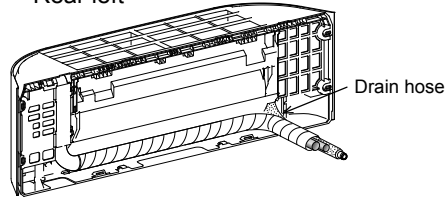

Drain hose

• Bottom right

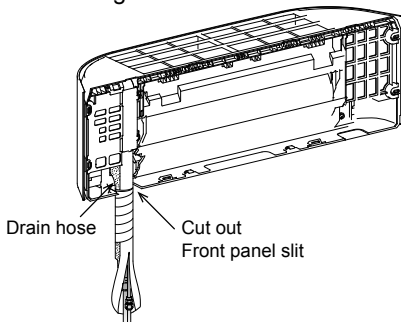
Drain hose
Cut out
Front panel slit

• Bottom left

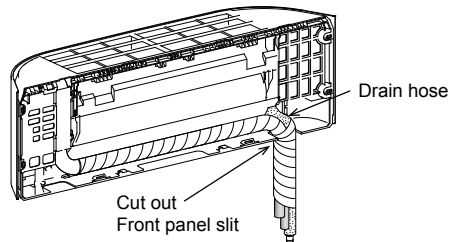
Drain hose
Cut out
Front panel slit

1. Die-cutting Front panel slit

- Cut out the slit on the bottom left or bottom right side of the Front panel for the bottom left or bottom right connection with a coping saw.

2. Changing drain hose

- The factory default of the drain hose is installed on the right side.
- For bottom-leftward connection and rear leftward connection's piping, it is necessary to change the drain hose and drain cap.

How to cutting the Front panel

- To connect piping to the bottom side, the Front panel must be cut off.
- The front panel can be removed by removing 2 screws securing then secure remove the front panel from the main body.
- ※ Be careful of air inlet grill fall down that may cause of injure or part damage.

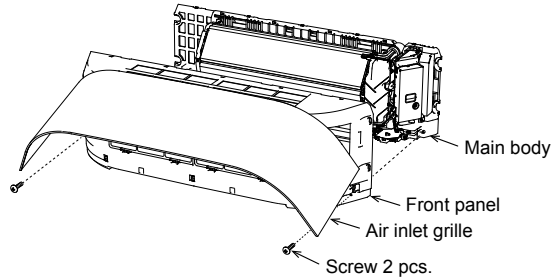

- The marking for cutting are indicated on the inside of the Front panel in the following positions.

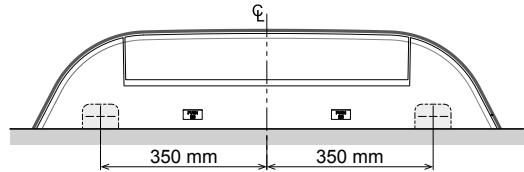

- Cut off the pipe exist from inside of Front panel using a coping saw or an equivalent tool.
- The plastic burrs from the cutting process should be removed with a half round file or an equivalent tool.

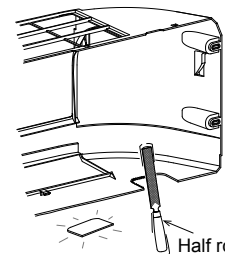
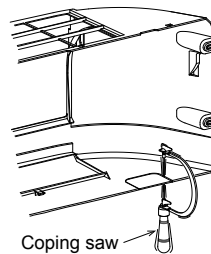

CAUTION

When cutting the Front panel, be careful of cutting tools and any sharp edges of plastic. It can cause injuries.

How to remove the drain hose

- Removed fixing screw of LED set then pull out it from the main body.
- Removed 2 screws to fix drain pan then secure remove the drain pan from the main body.

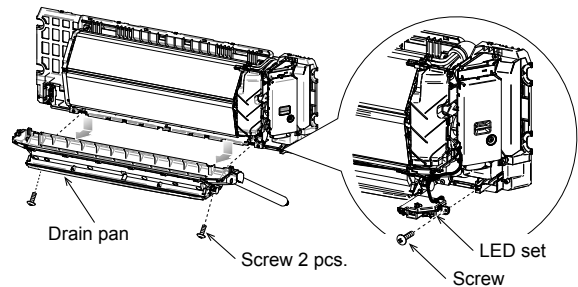

- The drain hose can be removed by removing the screw securing the drain hose then secure rotate steel plate of drain hose to out of the Drain pan and pulling out the drain hose.

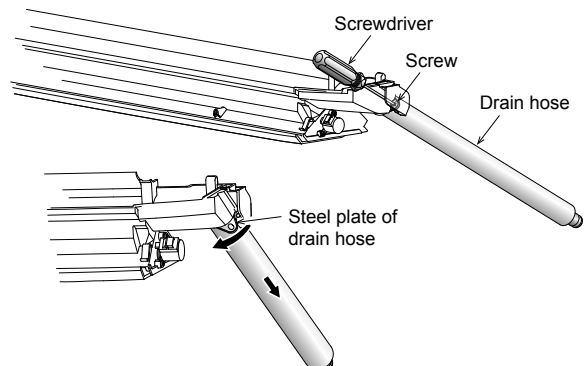

How to fix the drain hose

- To install the drain hose, insert the drain hose firmly until the connection part contacts with heat insulator, secure push steel plate of drain hose to predetermined position of Drain pan then fix it by original screw.

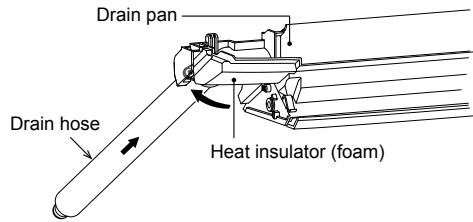

CAUTION

When removing or install the drain hose, be careful of any sharp edges of steel plate. The edges can cause injuries.

How to remove the drain cap

- Clip the drain cap by needle-nose pliers and pull out.

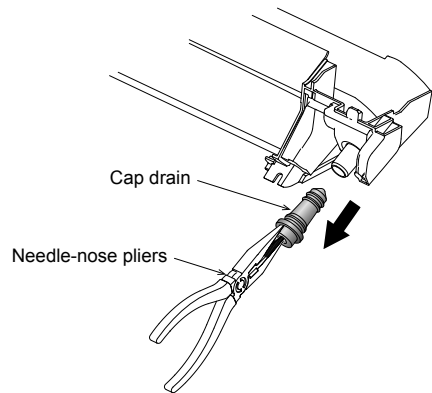

How to fix the drain cap

- Insert hexagonal wrench (dia. 4 mm) in a center head.

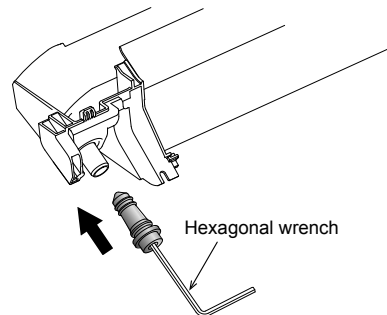

- Firmly insert the drain cap.

Do not apply lubricating oil (refrigerant machine oil) when inserting the drain cap. Application causes deterioration and drain leakage from the plug.

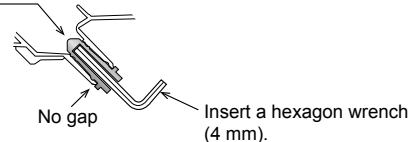

CAUTION

Firmly insert the drain hose and drain cap; otherwise, water may leak.

■ Left-hand connection with piping

- Bend the connecting pipe so that it is laid within 43 mm above the wall surface. If the connecting pipe is laid exceeding 43 mm above the wall surface, the indoor unit may unstably be set on the wall. When bending the connecting pipe, make sure to use a spring bender so as not to crush the pipe.

Bend the connecting pipe within a radius of 30 mm.

To connect the pipe after installation of the unit (figure)

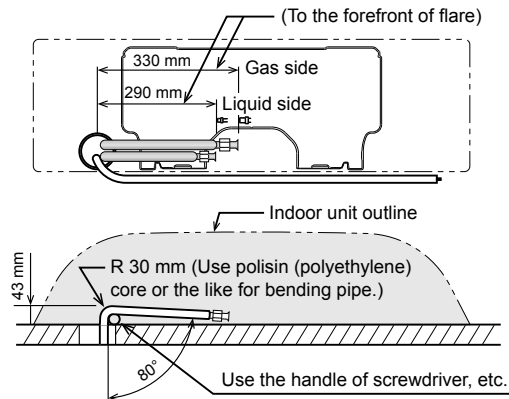

NOTE

If the pipe is bent incorrectly, the indoor unit may unstably be set on the wall. After passing the connecting pipe through the pipe hole, connect the connecting pipes to the auxiliary pipes and wrap the facing tape around them.

⚠ CAUTION

- Bind the auxiliary pipes (two), power supply and connecting cable with facing tape tightly.

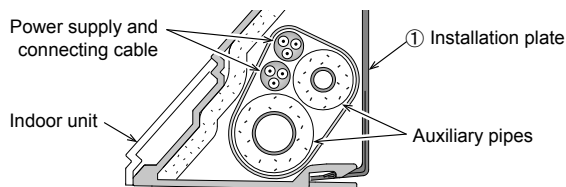

- Carefully arrange pipes so that any pipe does not stick out of the rear plate of the indoor unit.
- Carefully connect the auxiliary pipes and connecting pipes to one another and cut off the insulating tape wound on the connecting pipe to avoid double-taping at the joint; moreover, seal the joint with the vinyl tape, etc.
- Since dewing results in a machine trouble, make sure to insulate both connecting pipes. (Use polyethylene foam as insulating material.)
- When bending a pipe, carefully do it, not to crush it.

6 INDOOR UNIT FIXING

1. Pass the pipe through the hole in the wall, and hook the indoor unit on the installation plate at the upper hooks.
2. Swing the indoor unit to right and left to confirm that it is firmly hooked up on the installation plate.
3. While pressing the indoor unit onto the wall, hook it at the lower part on the installation plate. Pull the indoor unit toward you to confirm that it is firmly hooked up on the installation plate.

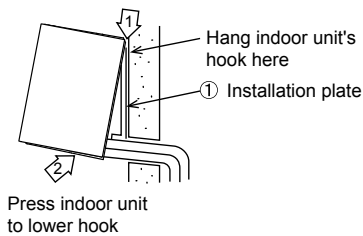

- For detaching the indoor unit from the installation plate, pull the indoor unit toward you while pushing its bottom up at the specified parts.

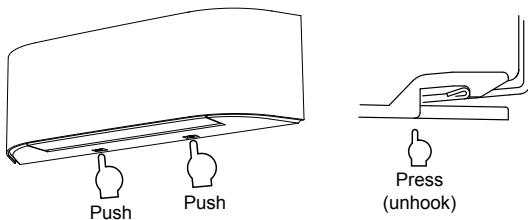

⚠ CAUTION

MOUNTING INDOOR UNIT TO THE INSTALLATION PLATE

- The lower part of indoor unit may float, due to the condition of piping and installer cannot fix it to the installation plate. In that case, use the screws provided to fix the indoor unit with the installation plate.
- Especially when the pipes are pulled out to the left side, the indoor unit must be screwed to the installation plate.

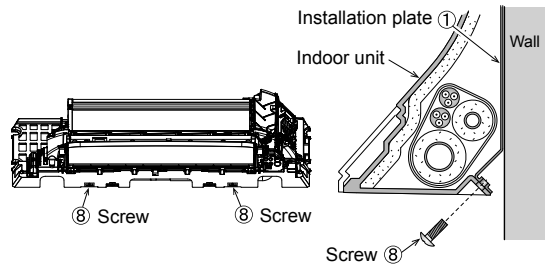

DIRECTLY MOUNTING INDOOR UNIT TO THE WALL

- In case left side or right of indoor unit may float, the provided screws should be used to fix the indoor unit directly to the wall at the predetermined position.
- In the case of block, brick, concrete or similar type wall, determining the mount screw position on the wall can be used symbol (▶) on the main body of indoor unit for drill hole to insert clip anchors for appropriate mounting screw.

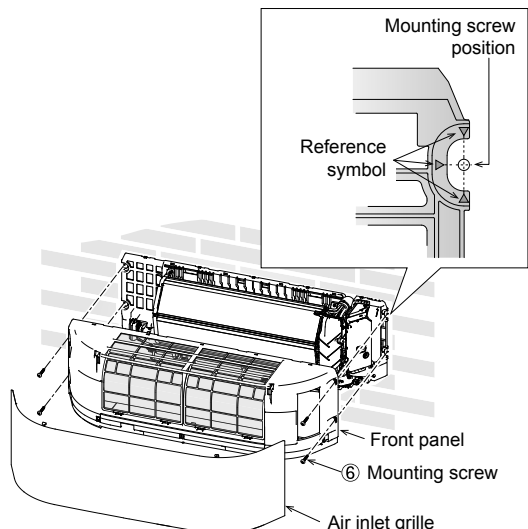

7 DRAINAGE

1. Run the drain hose sloped downwards.

NOTE

- Hole should be made at a slight downward slant on the outdoor side.

- Put water in the drain pan and make sure that the water is drained out of doors.
- When connecting extension drain hose, insulate the connecting part of extension drain hose with shield pipe.

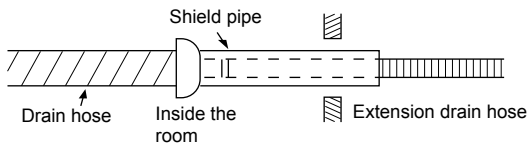
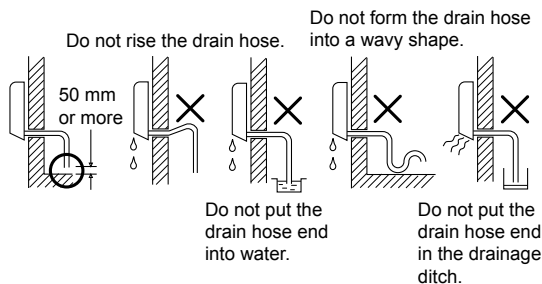

⚠ CAUTION

Arrange the drain pipe for proper drainage from the unit.

Improper drainage can result in dew-dropping.

This air conditioner has the structure designed to drain water collected from dew, which forms on the back of the indoor unit, to the drain pan. Therefore, do not store the power cord and other parts at a height above the drain guide.

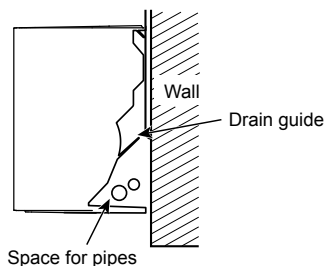

8 REFRIGERANT PIPING

CAUTION

Use flare nuts that are included with the unit. Using different flare nuts may cause refrigerant gas leakage.

■ Refrigerant Piping

Use the following item for the refrigerant piping.

Material: Seamless phosphorous de-oxidized copper pipe.

6.35, 9.52 and 12.7 wall thickness 0.8 mm or more.

15.88 wall thickness 1.0 mm or more.

REQUIREMENT

When the refrigerant pipe is long, provide support brackets at intervals of 2.5 - 3 m to clamp the refrigerant pipe. Otherwise, abnormal sound may be generated.

CAUTION

IMPORTANT 4 POINTS FOR PIPING WORK

1. Reusable mechanical connectors and flared joints are not allowed indoors. When mechanical connectors are reused indoors, sealing parts shall be renewed.
When flared joints are reused indoors, the flare part shall be re-fabricated.
2. Tight connection (between pipes and unit)
3. Evacuate the air in the connecting pipes by using VACUUM PUMP.
4. Check the gas leakage. (Connected points)

■ Pipe size

(dia.: mm)

MMK-	UP0051 to UP0121 type	UP0151 to UP0181 type
Gas side	9.5	12.7
Liquid side	6.4	6.4

■ Permissible Piping Length and Height Difference

They vary according to the outdoor unit. For details, refer to the Installation Manual attached to the outdoor unit.

Flaring

- Cut the pipe with a pipe cutter. Remove burrs completely. Remaining burrs may cause gas leakage.
- Insert a flare nut into the pipe, and flare the pipe. As the flaring sizes of R32 or R410A differ from those of refrigerant R22, the flare tools newly manufactured for R32 or R410A are recommended.

However, the conventional tools can be used by adjusting projection margin of the copper pipe.

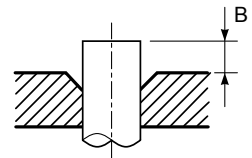

▼ Projection margin in flaring: B (Unit: mm)

RIDGID (Clutch type)

Outer dia. of copper pipe	Tool used	Conventional tool used
6.4, 9.5	0 to 0.5	1.0 to 1.5
12.7		

▼ Flaring dia. meter size: A (Unit: mm)

Outer dia. of copper pipe	A _{0.4} ⁺⁰
6.4	9.1
9.5	13.2
12.7	16.6

CAUTION

- Do not scratch the inner surface of the flared part when removing burrs.
- Flare processing under the condition of scratches on the inner surface of flare processing part will cause refrigerant gas leak.
- Check that the flared part is not scratched, deformed, stepped, or flattened, and that there are no chips adhered or other problems, after flare processing.
- Do not apply refrigerating machine oil to the flare surface.

* In case of flaring for R32 or R410A with the conventional flare tool, pull it out approx. 0.5 mm more than that for R22 to adjust to the specified flare size. The copper pipe gauge is useful for adjusting projection margin size.

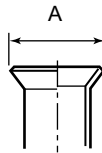

Tightening connection

⚠ CAUTION

- Do not apply excessive torque. Otherwise, the nut may crack depending on the conditions.

(Unit: N•m)

Outer dia. of copper pipe	Tightening torque
6.4 mm (dia.)	14 to 18 (1.4 to 1.8 kgf•m)
9.5 mm (dia.)	33 to 42 (3.3 to 4.2 kgf•m)
12.7 mm (dia.)	50 to 62 (5.0 to 6.2 kgf•m)

▼ Tightening torque of flare pipe connections

Pressure of R32 or R410A is higher than that of R22. (Approx. 1.6 times) Therefore, using a torque wrench, tighten the flare pipe connecting sections which connect the indoor and outdoor units of the specified tightening torque.

Incorrect connections may cause not only a gas leak, but also a trouble of the refrigeration cycle. Align the centers of the connecting pipes and tighten the flare nut as far as possible with your fingers. Then tighten the nut with a spanner and torque wrench as shown in the figure.

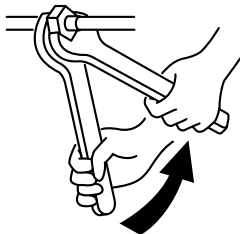

Work using double spanner

REQUIREMENT

Tightening with an excessive torque may crack the nut depending on installation conditions. Tighten the nut within the specified tightening torque.

Piping with outdoor unit

- Shape of valve differs according to the outdoor unit.
For details of installation, refer to the Installation Manual of the outdoor unit.

Heat insulation

Heat insulation for the pipes should be done separately for the liquid side and gas side. Because both of the liquid and gas side pipes become a low temperature during cooling operation, sufficient heat insulation should be done to prevent condensation.

- Heat insulator with a heat resistance of 120°C or more must be used for the gas side pipe.
- The pipe connection section of the indoor unit must be heat insulated securely and compactly with the attached heat insulator.

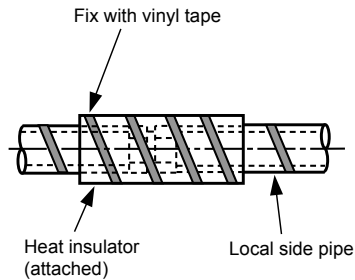

■ Airtight test / Air purge, etc.

For air tightness test, vacuum drying and adding refrigerant, refer to the Installation Manual attached to the outdoor unit.

⚠ CAUTION

Do not supply power to the indoor unit until the airtight test and vacuuming are completed. (If the indoor unit is powered on, the pulse motor valve is fully closed, which extends the time for vacuuming.)

■ Open fully valves of the outdoor unit

Open the valve of the outdoor unit fully. A hexagonal wrench is required for opening the valve.

For details, refer to the Installation Manual attached to the outdoor unit.

■ Gas leak check

Check with a leak detector or soap water whether gas leaks or not, from the pipe connecting section or cap of the valve.

REQUIREMENT

Use a leak detector manufactured exclusively HFC refrigerant (R410A, R134a, R32, etc.).

9 ELECTRICAL CONNECTION

WARNING

1. **Using the specified wires, ensure to connect the wires, and fix wires securely so that the external tension to the wires do not affect the connecting part of the terminals.**
Incomplete connection or fixation may cause a fire, etc.
2. **Be sure to connect earth wire. (grounding work)**
Incomplete grounding cause an electric shock.
Do not connect ground wires to gas pipes, water pipes, lightning rods or ground wires for telephone wires.
3. **Appliance shall be installed in accordance with national wiring regulations.**
Capacity shortage of power circuit or incomplete installation may cause an electric shock or a fire.

REQUIREMENT

- For power supply wiring, strictly conform to the Local Regulation in each country.
- For wiring of power supply of the outdoor units, follow the Installation Manual of each outdoor unit.
- Perform the electric wiring so that it does not come to contact with the high-temperature part of the pipe.
The coating may melt resulting in an accident.
- After connecting wires to the terminal blocks, provide a trap and fix wires with the cord clamp.
- Run the refrigerant piping line and control wiring line in the same line.
- Do not turn on the power of the indoor unit until vacuuming of the refrigerant pipes completes.

CAUTION

- **For communication line, use wires with the same type and size. If each wire has a different type and size from another one, it will cause a communication trouble.**
- If incorrect/incomplete wiring is carried out, it will cause an electrical fire or smoke.
- Install an earth leakage breaker that is not tripped by shock waves. If an earth leakage breaker is not installed, an electric shock may be caused.
- Use the cord clamps attached to the product.
- Do not damage or scratch the conductive core and inner insulator of power and system interconnection wires when peeling them.
- Use the power supply wire and control wires of specified thickness, type, and protective devices required.
- Do not connect 208V – 240V power to the terminal blocks (Uv (U1)), (Uv (U2)), (A), (B) for control wiring.
(Otherwise, the system will fail.)
- Perform the electric wiring so that it does not come to contact with the high-temperature part of the pipe.
The coating may melt resulting in an accident.

■ Power supply wire and communication wires specifications

Power supply wire and communication wires are procured locally.

For the power supply specifications, follow the table below. Power supply wiring and communication wiring are to be procured locally.

For specifications of the power capacity of the outdoor unit and the power supply wires, refer to the Installation Manual supplied with the outdoor unit.

Indoor unit power supply

- Prepare an exclusive power supply for the indoor unit independently of the outdoor unit.
- Arrange the power supplies to the indoor and outdoor units, so that a common earth leakage breaker and main switch can be used.
- Power supply wire specification: Cable 3-core 2.5 mm², **in conformity with Design H07RN-F or 60245 IEC 57.**

▼ Power supply

Power supply	220-240V ~ 50Hz 208-230V ~ 60Hz
Power supply switch/Earth leakage breaker or power supply wiring/fuse rating for indoor units should be selected by the accumulated total current values of the indoor units.	
Power supply wiring	Below 50 m 2.5 mm ²

Control wiring, Central controller wiring

- Use a 2 core non polarity wire.
- To prevent any possible noise issues, use a shielded 2 core wire.
- The total stated length of communication wiring is determined by the interconnecting length of indoor to outdoor wire plus the length of the central control communication wire.

▼ Communication line

TU2C-Link models (U series) can be combined with TCC-Link models (other than U series).

For details of communication type, refer to the following table.

Communication type and model names

Communication type	TU2C-Link (U series and future models)	TCC-Link (Other than U series)
Outdoor unit	MMY-MUP*** ↑ This letter indicates U series model.	Other than U series MMY-MHP*** MCY-MHP*** MMY-MAP***
Indoor unit	MM*-UP*** ↑ This letter indicates U series model.	Other than U series MM*-AP***
Wired remote controller	RBC-ASCU*** ↑ This letter indicates U series model.	Other than U series
Wireless remote controller kit & receiver unit	RBC-AXU*** ↑ This letter indicates U series model.	Other than U series

U series outdoor unit : SMMS-u (MMY-MUP*)**

Other than U series outdoor unit : SMMS-i, SMMS-e etc. (MMY-MHP*)**

<In the case of combining with outdoor units of Super Modular Multi System u series (SMMS-u)>

Uv line and Uc line (L2, L3, L4) (2-core shield wire, non-polarity)	Wire size : 0.5 mm ² (Up to 500 m) 0.75 to 1.25 mm ² (Up to 1000 m)
Uh line (L1) (2-core shield wire, non-polarity)	Wire size : 0.75 to 1.25 mm ² (Up to 1000 m) 2.0 mm ² (Up to 2000 m)

- **U (v, h, c)** line means of control wiring.
Uv line : Between indoor and outdoor units.
Uh line : Central control line.
Uc line : Between outdoor and outdoor units.
- **Uv line and Uc line** are independent from another refrigerant line. Total length of **Uv** and **Uc** lines (**L3+L4**) in each refrigerant line is up to 1000 m.

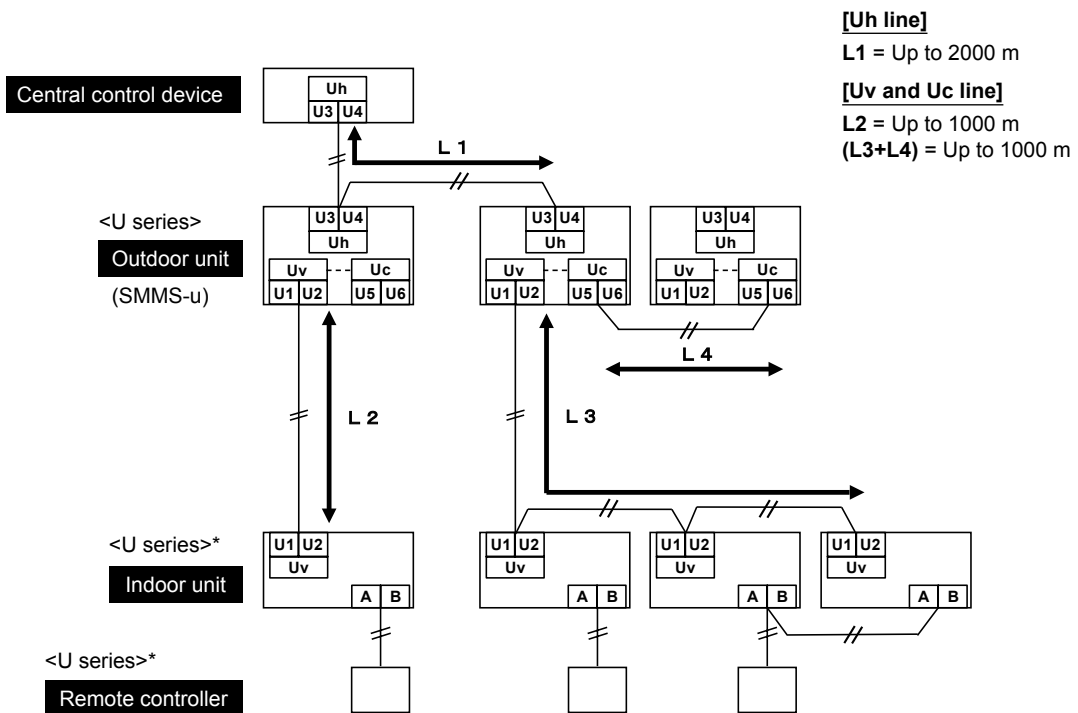

* Even if the indoor unit and the remote controller are "other than U series", the wiring specification are the same.

<In the case of combining with outdoor units other than Super Modular Multi System u series (SMMS-u)>

Control wiring between indoor units, and outdoor unit (L2, L3) (2-core shield wire, non-polarity)	Wire size : 1.25 mm ² (Up to 1000 m) 2.0 mm ² (Up to 2000 m)
Central control line wiring (L1) (2-core shield wire, non-polarity)	
Control wiring between outdoor units (L4) (2-core shield wire, non-polarity)	Wire size : 1.25 to 2.0 mm ² (Up to 100 m)

- The length of the communication line (L1+L2+L3) means the total length of the inter-unit wire length between indoor and outdoor units added with the central control system wire length.

[Communication line]

(L1+L2+L3) = Up to 2000 m

L4 = Up to 100 m

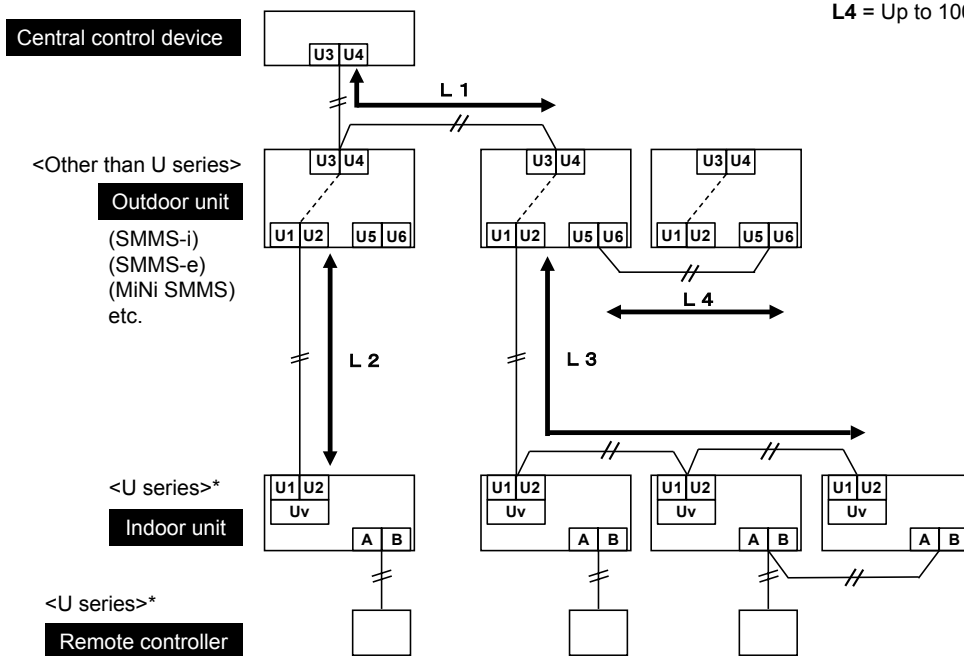

* Even if the indoor unit and the remote controller are “other than U series”, the wiring specification are the same.

Wired remote controller wiring

This wiring is not required when using the supplied wireless remote controller.

- For wiring remote controllers a 2 core non polarity wire must be used.

Wired remote controller wiring, remote controller inter-unit wiring	Wire size: 0.5 mm ² to 2.0 mm ²	
Total wire length of wired remote controller wiring and remote controller inter-unit wiring = L + L1 + L2 + ... Ln	In case of wired type only	Up to 500 m
	In case of wireless type included	Up to 400 m
Total wire length of wired remote controller inter-unit wiring = L1 + L2 + ... Ln	Up to 200 m	

⚠ CAUTION

- The remote controller wire (Communication line) and AC 208-240V wires cannot be parallel to contact each other and cannot be stored in the same conduits. If doing so, a trouble may be caused on the control system due to noise, etc.
- If U series models (TU2C-Link) are combined with models other than U series (TCC-Link), the wiring specifications and maximum number of connectable indoor units will be changed. Pay attentions to their communication specifications when carrying out the installation, maintenance, or repair. For its details, refer to the "Communication line" in **9 Electrical connection**.

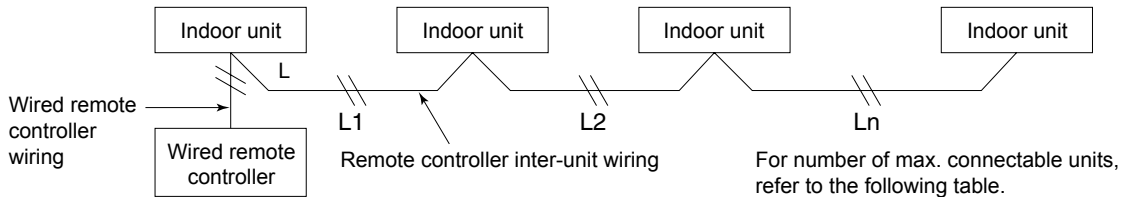

Max. number of connectable indoor units, and communication type

Outdoor unit	Unit type							
	U series	U series	U series	U series	*	*	*	*
Indoor unit	U series	U series	*	*	U series	U series	*	*
Remote controller	U series	*	U series	*	U series	*	U series	*
Communication type	TU2C-Link		TCC-Link					
Max. number of connectable unit	16		8					

* : Other than U series

■ Control wiring between indoor and outdoor units

NOTE

- A wiring diagram below is an example for connection to SMMS-u series. For connecting to other outdoor unit series, refer to the Installation Manual attached to the outdoor unit to be connected.

▼ Wiring example

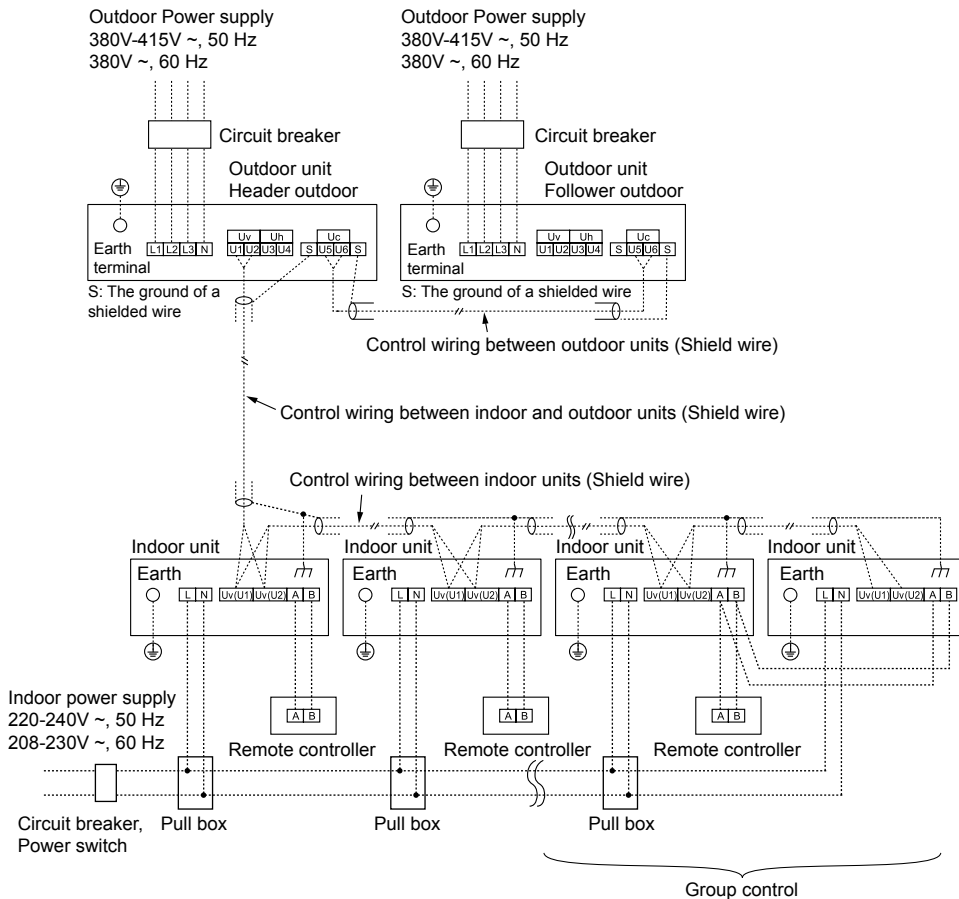

■ Address setup

Set up the addresses as per the Installation Manual supplied with the outdoor unit.

■ Wired remote controller wiring

- As the wired remote controller wire has non-polarity, there is no problem if connections to indoor unit terminal blocks A and B are reversed.

▼ Wiring diagram

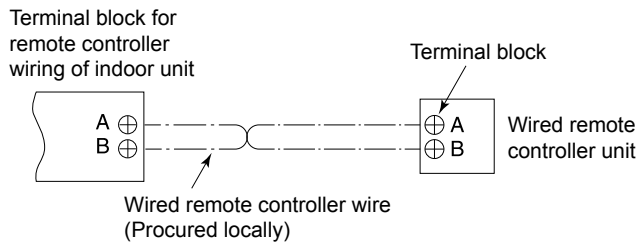

■ Wiring Connection

How to connect the power supply wiring and control wiring

The power supply wire and the control wire can be connected without removing the front panel.

REQUIREMENT

Connect the power supply wire after connecting the control wire for this model.

1. Remove the air inlet grille.
Open the air inlet grille upward and pull it toward you.
2. Remove the terminal cover and the clamp base.
3. Insert the power supply wire and control wire (according to the local rule) into the pipe hole on the wall.
4. Take the power supply wire out of the cable slot on the rear panel so that it protrudes about 150 mm from the front.
5. Insert the control wire fully into the control/wired remote controller terminal block (Uv (U1)), (Uv (U2)), (A), (B) and secure it tightly with screws.
6. Clamp the control wire with the cord clamp.
7. Install the clamp base with a screw.
8. Insert the power supply wire fully into the terminal block and secure it tightly with screws. Tightening torque: 1.2 N·m (0.12 kgf·m) Secure the earth line with the earth screw.
9. Clamp the power supply wire with the cord clamp.
10. Attach the terminal cover and the air inlet grille to the indoor unit.

CAUTION

- Be sure to refer to the wiring diagram attached inside the front panel.
- Check local electrical cords and also any specific wiring instructions and limitations.
- Do not catch the control wire when installing the clamp base.

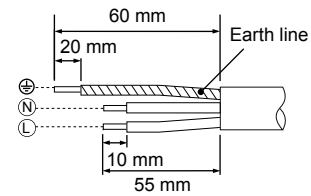
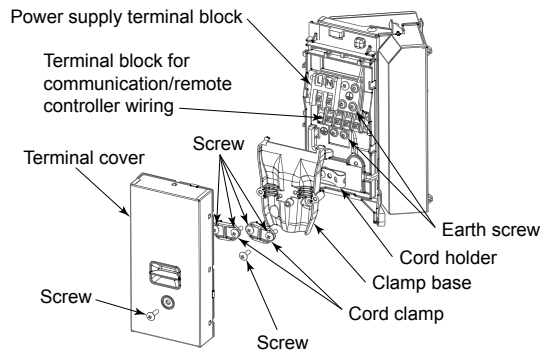

<Stripping length of the power supply wire>

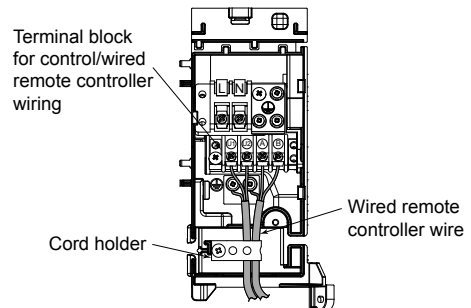
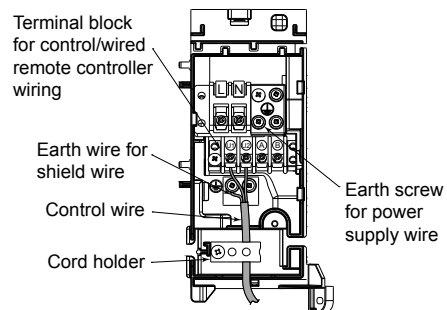

<Connecting wired remote controller wire>

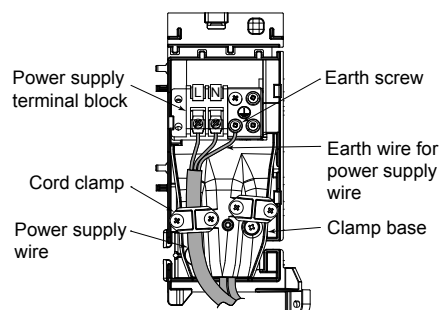

■ Wiring connection for flow selector unit

How to connect the wiring of flow selector unit

Connect the power supply wire and the communication wire supplied with the flow selector unit to the indoor unit.

1. Remove the air inlet grille.
Open the air inlet grille upward and pull it toward you.
2. Remove the terminal cover and the clamp base.
3. Insert the control wire fully into the control/wired remote controller terminal block and secure it tightly with screws.
4. Connect the control wire connector of the flow selector unit to the lead with a connector to the left of the control/wired remote controller terminal block.
5. Clamp the control wire and the control wire of the flow selector unit with the cord clamp.
6. Install the clamp base with a screw.
7. Insert the power supply wire fully into the terminal block and secure it tightly with screws.
Tightening torque: 1.2 N·m (0.12 kgf·m)
Secure the earth line with the earth screw.
8. Clamp the power supply wire with the cord clamp.
9. Insert the power supply wire fasten terminal of the flow selector unit into the power supply terminal.
- Secure the earth line with the earth screw.
10. Clamp the power supply wire of the flow selector unit tight with the cord clamp.
11. Attach the terminal cover, the front panel and the air inlet grille to the indoor unit.

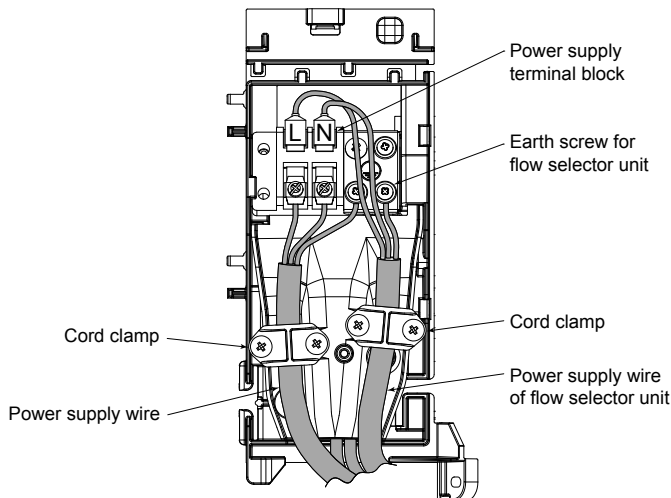

CAUTION

Confirm that every wires are stored in the electric parts box without getting caught before attaching the terminal cover.

10 APPLICABLE CONTROLS

REQUIREMENT

When the air conditioner is used for the first time, it will take some moments after the power has been turned on before the remote controller becomes available for operations: This is normal and is not indicative of trouble.

- Concerning the automatic addresses
(The automatic addresses are set up by performing operations on the outdoor interface circuit board.)
While the automatic addresses are being set up, no remote controller operations can be performed.
Setup takes up to 10 minutes (usually about 5 minutes).
- When the power is turned on after automatic address setup, it takes up to 10 minutes (usually about 3 minutes) for the outdoor unit to start operating after the power has been turned on.

Before the air conditioner was shipped from the factory, all units are set to [STANDARD] (factory default).

If necessary, change the indoor unit settings. The settings are changed by operating the wired remote controller.

- * The settings cannot be changed using only a wireless remote controller, simple remote controller or group control remote controller by itself so install a wired remote controller separately as well.

■ Applicable controls setup (settings at the site)

Remote controller model name:
RBC-ASCU11-E

Basic procedure

Be sure to stop the air conditioner before making settings.

(Change the setup while the air conditioner is not working.)

CAUTION

Set only the Code No. shown in the following table: DO NOT set any other Code No.

If a Code No. not listed is set, it may not be possible to operate the air conditioner or other trouble with the product may result.

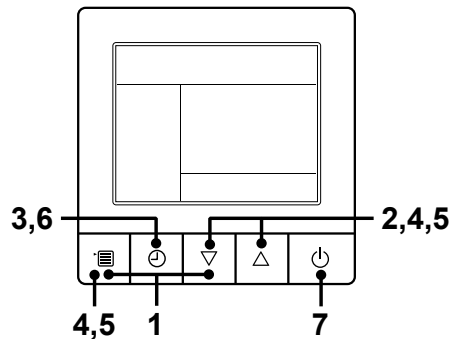

- 1 Push and hold menu button and [▽] setting button simultaneously for 10 seconds or more.

- After a while, the display flashes as shown in the figure. "ALL" is displayed as indoor unit numbers during initial communication immediately after the power has been turned on.

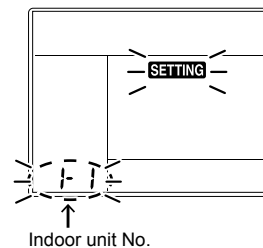

- 2 Each time [▽] [△] setting button is pushed, indoor unit numbers in the group control change cyclically. Select the indoor unit to change settings for.

- The fan of the selected indoor unit runs.
The indoor unit can be confirmed for which to change settings.

- 3 Push OFF timer button to confirm the selected indoor unit.

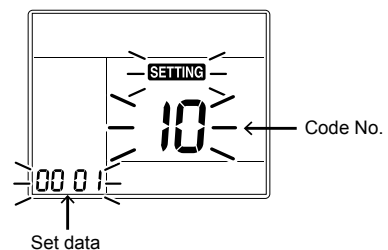

- 4 Push the menu button to make Code No. [**] flash. Change Code No. [**] with [▽] [△] setting button.

- 5** Push the menu button to make Set data [***] flash. Change Set data [***] with [▽] [△] setting button.
- 6** Push OFF timer button.
By doing so, the setup is completed.
- To change other settings of the selected indoor unit, repeat from Procedure **4**.
- 7** When all the settings have been completed, push ON/OFF button to determine the settings.
“SETTING” flashes and then the display content disappears and the air conditioner enters the normal stop mode. (The remote controller is unavailable while “SETTING” is flashing.)
- To change settings of another indoor unit, repeat from Procedure **1**.

■ Change of lighting time of filter sign

According to the installation condition, the lighting time of the filter sign (Notification of filter cleaning) can be changed.

Follow to the basic operation procedure

(**1** → **2** → **3** → **4** → **5** → **6**).

- For the CODE No. in Procedure **4**, specify [01].
- For the [SET DATA] in Procedure **5**, select the SET DATA of filter sign lighting time from the following table.

SET DATA	Filter sign lighting time
0000	None
0001	150H (Factory setting)
0002	2500H
0003	5000H
0004	10000H

■ To secure better effect of heating

When it is difficult to obtain satisfactory heating due to installation place of the indoor unit or structure of the room, the detection temperature of heating can be raised. Also use a circulator, etc. to circulate heat air near the ceiling.

Follow to the basic operation procedure

(**1** → **2** → **3** → **4** → **5** → **6**).

- For the CODE No. in Procedure **4**, specify [06].
- For the SET DATA in Procedure **5**, select the SET DATA of shift value of detection temperature to be set up from the table below.

SET DATA	Detection temp shift value
0000	No shift
0001	+1°C
0002	+2°C (Factory setting)
0003	+3°C
0004	+4°C
0005	+5°C
0006	+6°C

■ Adjustment of air direction

1. Using the remote controller switch, change the up/down air direction by moving the horizontal louver.
2. Adjust the right/left air direction by bending the vertical grille inside of the air outlet port with hands.

REQUIREMENT

Do not touch the horizontal louver directly with hands; otherwise a trouble may be caused. For handling of the horizontal louver, refer to "Owner's Manual" attached to the outdoor unit.

■ Group control

In a group control, a remote controller can control up to maximum 8 or 16 units. (Depending on the connecting unit type in page 22)

- The wired remote controller only can control a group control. The wireless remote controller is unavailable for this control.
- For cabling procedure and cables of the individual line (Identical refrigerant line) system, refer to "Electrical Connection" in this Manual.
- Cabling between indoor units in a group is performed in the following procedure.
Connect the indoor units by connecting the remote controller inter-unit cables from the remote controller terminal blocks (A, B) of the indoor unit connected with a remote controller to the remote controller terminal blocks (A, B) of the other indoor unit. (Non-polarity)
- For address setup, refer to the Installation Manual attached to the outdoor unit.

11 TEST RUN

■ Before test run

- Before turning on the power supply, carry out the following procedure.
 - 1) By using insulation tester (500VMΩ), check that resistance of 1MΩ or more exists between the terminal block L to N and the earth (grounding).
If resistance of less than 1MΩ is detected, do not run the unit.
 - 2) Check the valve of the outdoor unit being opened fully.
- To protect the compressor at activation time, leave power-ON for 12 hours or more before operating.
- Before starting a test run, set addresses by following the Installation Manual supplied with the outdoor unit.

◆ Requirements for turning thermostat OFF

Cooling operation

- When the outdoor/suction air temperature is lower than or equal to 19°C.
- When the outdoor/suction air temperature is lower than or equal to 3°C above the set temperature.

Heating operation

- When the outdoor/suction air temperature is lower than or equal to -10°C.
- When the outdoor/suction air temperature is higher than or equal to 15°C.
- When the outdoor/suction air temperature is higher than or equal to 3°C above the set temperature.

■ Execute a test run

- When a fan operation is to be performed for an individual indoor unit, turn off the power, short circuit CN72 on the circuit board, and then turn the power back on. (Set the operation mode to “fan” to operate the unit.) When the test run has been performed using this method, be sure to release the short circuit of CN72 after the test run is completed.

Operate the unit with the remote controller as usual.

For the procedure of the operation, refer to the attached Owner's Manual to the outdoor unit. A forced test run can be executed in the following procedure even if the operation stops by thermostat-OFF.

In order to prevent a serial operation, the forced test run is released after 60 minutes have passed and returns to the usual operation.

CAUTION

- Do not use the forced test run for cases other than the test run because it applies an excessive load to the devices.

Wired remote controller

Be sure to stop the air conditioner before making settings.

(Change the setup while the air conditioner is not working.)

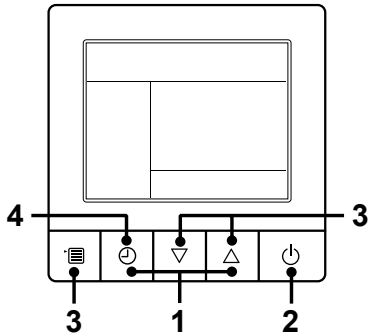

- 1 Push and hold OFF timer button and [△] setting button simultaneously for 10 seconds or more. [TEST] is displayed on the display part and the test run is permitted.

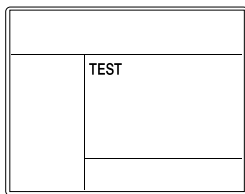

- 2 Push ON/OFF button.
- 3 Push menu button to select the operation mode. Select [Cool] or [Heat] with [▽] [△] setting button, and then push menu button (three times) again to determine the operation mode.
 - Do not run the air conditioner in a mode other than [Cool] or [Heat].
 - The temperature setting function does not work during test run.
 - The check code is displayed as usual.
- 4 After the test run, push OFF timer button to stop a test run. ([TEST] disappears on the display and the air conditioner enters the normal stop mode.)

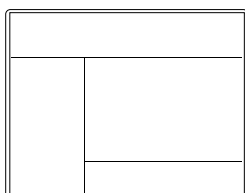

In case of wireless remote controller (Forced test operation is performed in a different way.)

REQUIREMENT

- For the operation procedure, be sure to follow the Owner's Manual.
- Finish the forced cooling operation in a short time because it applies excessive strength to the air conditioner.
- A test operation of forced heating is unavailable. Perform a test operation by heating operation using the switches of the remote controller. However heating operation may be not carried out according to the temperature conditions.

- Check wiring/piping of indoor and outdoor units

1. When pushing [RESET] button for 10 seconds or more, "Pi!" sound is heard and the operation changes to a forced cooling operation. After approx. 3 minutes, a cooling operation starts forcibly. Check cool air starts blowing. If the operation does not start, check wiring again.
2. To stop a test operation, push [RESET] button once again (Approx. 1 second). The louver closes and the operation stops.
 - Check wiring/piping of the indoor and outdoor units in forced cooling operation.

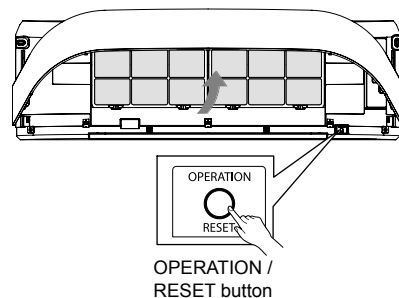

- Check transmission of remote controller

1. Push "START/STOP" button of the remote controller to check an operation can also start by the remote controller.
 - "Cooling" operation by the remote controller may be unavailable according to the temperature conditions.

12 TROUBLESHOOTING

A wired remote controller is necessary for this function. This function cannot be operate with a wireless remote controller.

■ Confirmation and check

If a problem occurs with the air conditioner, the OFF timer indicator alternately shows the check code and the indoor Unit No. in which the problem occurred.

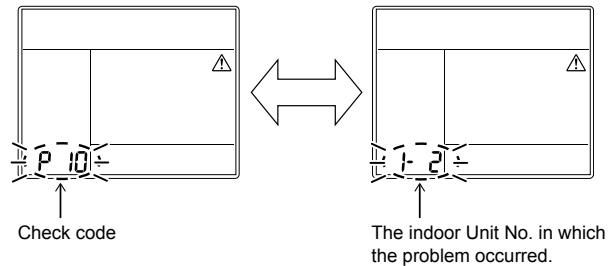

■ Troubleshooting history and confirmation

You can check the troubleshooting history with the following procedure if a problem occurs with the air conditioner.

(The troubleshooting history records up to 4 incidents.)

You can check it during operation or when operation is stopped.

- If you check the troubleshooting history during OFF timer operation, the OFF timer will be canceled.

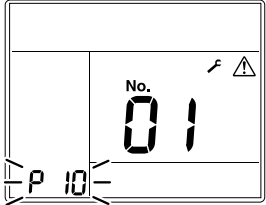
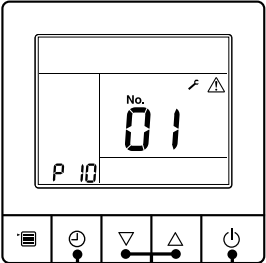
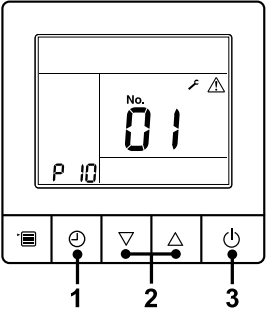
Procedure	Description of operation
<p>1</p>	<p>Push the OFF timer button for over 10 seconds and the indicators appear as an image indicating the troubleshooting history mode has been entered. If [Service check] is displayed, the mode enters in the troubleshooting history mode.</p> <ul style="list-style-type: none"> • [01: Order of troubleshooting history] appears in the temperature indicator. • The OFF timer indicator alternately shows the [check code] and the [indoor Unit No.] in which the problem occurred. 
<p>2</p>	<p>Each time the setting button is pushed, the recorded troubleshooting history is displayed in sequence. The troubleshooting history appears in order from [01] (newest) to [04] (oldest).</p> <p>CAUTION</p> <p>In the troubleshooting history mode, DO NOT push the Menu button for over 10 seconds, doing so deletes the entire troubleshooting history of the indoor unit.</p> 
<p>3</p>	<p>After you have finished checking, push the ON/OFF button to return to the regular mode.</p> <ul style="list-style-type: none"> • If the air conditioner is operating, it remains operated even after the ON/OFF button has been pushed. To stop its operation, push the ON/OFF button again. 

■ Check method

On the remote controller (Wired remote controller, Central control remote controller) and the interface P.C. Board of the outdoor unit (I/F), a check display LCD (Remote controller) or 7-segment display (on the outdoor interface P.C. Board) to display the operation is provided. Therefore the operation status can be known. Using this self-diagnosis function, a trouble or position with error of the air conditioner can be found as shown in the table below.

■ Check code list

The following list shows each check code. Find the check contents from the list according to part to be checked.

- In case of check from indoor remote controller: See “Wired remote controller display” in the list.
- In case of check from outdoor unit: See “Outdoor 7-segment display” in the list.
- In case of check from indoor unit with a wireless remote controller: See “Sensor block display of receiving unit” in the list.

○ : Lighting, ◻ : Flashing, ● : Goes off
 ALT: Flashing is alternately when there are two flashing LED.
 SIM: Simultaneous flashing when there are two flashing LED.
 Inverter: Compressor / Fan inverter P.C. Board
 I/F: Interface P.C. Board

Check code			Wireless remote controller				Check code name	Judging device
Wired remote controller display	Outdoor unit 7-segment display		Sensor block display of receiving unit					
		Auxiliary code	Operation	Timer	Ready	Flash		
E01	–	–	◻	●	●		Communication trouble between indoor unit and remote controller (Detected at remote controller side)	Remote controller
E02	–	–	◻	●	●		Remote controller transmission trouble	Remote controller
E03	–	–	◻	●	●		Communication trouble between indoor unit and remote controller (Detected at indoor unit side)	Indoor unit
E04	–	–	●	●	◻		Communication circuit trouble between indoor / outdoor unit (Detected at indoor unit side)	Indoor unit
E06	E06	No. of indoor units in which sensor has been normally received	●	●	◻		Decrease of No. of indoor units	I/F
–	E07	–	●	●	◻		Communication circuit trouble between indoor / outdoor unit (Detected at outdoor unit side)	I/F
E08	E08	Duplicated indoor unit addresses	◻	●	●		Duplicated indoor unit addresses	Indoor unit • I/F
E09	–	–	◻	●	●		Duplicated master remote controllers	Remote controller
E10	–	–	◻	●	●		Communication trouble between indoor unit MCU	Indoor unit
E11	–	–	◻	●	●		Communication trouble between Application control kit and Indoor unit	Indoor unit Application control kit
E12	E12	01: Indoor/Outdoor units communication 02: Outdoor/Outdoor units communication	◻	●	●		Automatic address start trouble	I/F
E15	E15	–	●	●	◻		No indoor unit during automatic addressing	I/F
E16	E16	00: Capacity over 01: No. of connected units	●	●	◻		Capacity over / No. of connected indoor units	I/F
E17	–	–	◻	●	●		Communication trouble between indoor unit and Flow Selector unit	Indoor unit
E18	–	–	◻	●	●		Communication trouble between header and follower units Indoor unit	Indoor unit
E19	E19	00: Header is not detected 02: Two or more header units	●	●	◻		Outdoor header units quantity trouble	I/F

Wired remote controller display		Check code		Wireless remote controller				Check code name	Judging device
		Outdoor unit 7-segment display		Sensor block display of receiving unit					
			Auxiliary code	Operation	Timer	Ready	Flash		
E20	E20	01: Outdoor unit of other line connected 02: Indoor unit of other line connected	●	●	○		Other line connected during automatic address	I/F	
E23	E23	–	●	●	○		Sending trouble in communication between outdoor units Trouble in number of heat storage units (trouble with reception)	I/F	
E25	E25	–	●	●	○		Duplicated follower outdoor addresses	I/F	
E26	E26	No. of outdoor units which received signal normally	●	●	○		Decrease of No. of connected outdoor units	I/F	
E28	E28	Detected outdoor unit number	●	●	○		Follower outdoor unit trouble	I/F	
E31	E31	*1 Inverter quantity information	●	●	○		Inverter communication trouble	I/F	
F01	–	–	○	○	●	ALT	Indoor unit TCJ sensor trouble	Indoor unit	
F02	–	–	○	○	●	ALT	Indoor unit TC2 sensor trouble	Indoor unit	
F03	–	–	○	○	●	ALT	Indoor unit TC1 sensor trouble	Indoor unit	
F04	F04	–	○	○	○	ALT	TD1 sensor trouble	I/F	
F05	F05	–	○	○	○	ALT	TD2 sensor trouble	I/F	
F06	F06	01: TE1 sensor 02: TE2 sensor 03: TE3 sensor	○	○	○	ALT	TE1, TE2 or TE3 sensor trouble	I/F	
F07	F07	01: TL1 sensor 02: TL2 sensor 03: TL3 sensor	○	○	○	ALT	TL1, TL2 or TL3 sensor trouble	I/F	
F08	F08	–	○	○	○	ALT	TO sensor trouble	I/F	
F09	F09	01: TG1 sensor 02: TG2 sensor 03: TG3 sensor	○	○	○	ALT	TG1, TG2 or TG3 sensor trouble	I/F	
F10	–	–	○	○	●	ALT	Indoor unit TA sensor trouble	Indoor unit	
F11	–	–	○	○	●	ALT	TF sensor trouble	Indoor unit	
F12	F12	01: TS1 sensor 03: TS3 sensor 04: TS3 sensor disconnect	○	○	○	ALT	TS1 or TS3 sensor trouble	I/F	
F13	F13	1*: Comp. 1 side 2*: Comp. 2 side	○	○	○	ALT	TH sensor trouble	Inverter	
F15	F15	–	○	○	○	ALT	Outdoor unit temp. sensor miswiring (TE, TL)	I/F	
F16	F16	–	○	○	○	ALT	Outdoor unit pressure sensor miswiring (Pd, Ps)	I/F	
F22	F22	–	○	○	○	ALT	TD3 sensor trouble	I/F	
F23	F23	–	○	○	○	ALT	Ps sensor trouble	I/F	
F24	F24	–	○	○	○	ALT	Pd sensor trouble	I/F	
F29	–	–	○	○	●	SIM	Indoor unit other trouble	Indoor unit	
F30	F30	–	○	○	○	SIM	Occupancy sensor trouble	Indoor unit	
F31	F31	–	○	○	○	SIM	Indoor unit EEPROM trouble	I/F	
H01	H01	1*: Comp. 1 side 2*: Comp. 2 side	●	○	●		Compressor break down	Inverter	
H02	H02	1*: Comp. 1 side 2*: Comp. 2 side	●	○	●		Compressor trouble (lock)	Inverter	
H03	H03	1*: Comp. 1 side 2*: Comp. 2 side	●	○	●		Current detect circuit system trouble	Inverter	
H04	H04	–	●	○	●		Comp. 1 case thermostat operation	I/F	
H05	H05	–	●	○	●		TD1 sensor miswiring	I/F	
H06	H06	–	●	○	●		Low pressure protective operation	I/F	
H07	H07	–	●	○	●		Oil level down detective protection	I/F	
H08	H08	01: TK1 sensor trouble 02: TK2 sensor trouble 03: TK3 sensor trouble 04: TK4 sensor trouble 05: TK5 sensor trouble	●	○	●		Oil level detective temp. sensor trouble	I/F	

Wired remote controller display		Check code		Wireless remote controller				Check code name	Judging device
		Outdoor unit 7-segment display		Sensor block display of receiving unit					
			Auxiliary code	Operation	Timer	Ready	Flash		
H14	H14	–	●	○	●		Comp. 2 case thermostat operation	I/F	
H15	H15	–	●	○	●		TD2 sensor miswiring	I/F	
H16	H16	01: TK1 oil circuit system trouble 02: TK2 oil circuit system trouble 03: TK3 oil circuit system trouble 04: TK4 oil circuit system trouble 05: TK5 oil circuit system trouble	●	○	●		Oil level detective circuit trouble	I/F	
H17	H17	1* : Compressor 1 side 2* : Compressor 2 side	●	○	●		Compressor trouble (Step out)	I/F	
H25	H25	–	●	○	●		TD3 sensor miswiring	I/F	
J02	–	–	●	○	○	SIM	Communication trouble between control boards in Flow Selector unit	Indoor unit	
J03	–	–	●	○	○	SIM	Duplicated Flow Selector unit addresses	Indoor unit	
J10	J10	Detected indoor unit address	●	○	○	SIM	Flow Selector unit overflow trouble	Indoor unit	
J11	–	–	●	○	○	SIM	Flow Selector unit temperature sensor (TCS) trouble		
J29	–	–	●	○	○	SIM	Refrigerant leak detection sensor trouble	Indoor unit	
J30	J30	Detected indoor unit address * Not displayed depending on the DN code (I.DN) setting	●	○	○	SIM	Refrigerant leak detection	Indoor unit	
J31	–	–	●	○	○	SIM	Refrigerant leak detection sensor exceeding its life of the product	Indoor unit	
L02	L02	Detected indoor unit address	○	●	○	SIM	Model mismatch of indoor and outdoor unit Indoor unit incompatible with A2L (R32) refrigerant	I/F	
L03	–	–	○	●	○	SIM	Indoor unit center unit duplicated	Indoor unit	
L04	L04	–	○	○	○	SIM	Outdoor unit line address duplicated	I/F	
L05	–	–	○	●	○	SIM	Duplicated indoor units with priority (Displayed in indoor unit with priority)	I/F	
L06	L06	No. of indoor units with priority	○	●	○	SIM	Duplicated indoor units with priority (Displayed in unit other than indoor unit with priority)	I/F	
L07	–	–	○	●	○	SIM	Group line in individual indoor unit	Indoor unit	
L08	L08	–	○	●	○	SIM	Indoor unit group/Address unset	Indoor unit, I/F	
L09	–	–	○	●	○	SIM	Indoor unit capacity unset	Indoor unit	
L10	L10	–	○	○	○	SIM	Outdoor unit capacity unset	I/F	
L11	L11	Detected indoor unit address	○	○	○	SIM	Flow Selector unit not connected	I/F	
L12	L12	01: Flow Selector unit installation trouble	○	○	○	SIM	Flow Selector unit system trouble	I/F	
L13	L13	Detected indoor unit address	○	○	○	SIM	Safety device setting unmatched	I/F	
L14	L14	Detected indoor unit address	○	○	○	SIM	Safety device nonconformity	I/F	
L17	L17	–	○	○	○	SIM	Outdoor unit type mismatch trouble	I/F	
L18	L18	Detected indoor unit address	○	○	○	SIM	Flow Selector unit trouble	I/F	
L20	–	–	○	○	○	SIM	Duplicated central control addresses	Indoor unit	
L22	–	–	○	○	○	SIM	There is a DX-kit (heat source capacity command) non-compliant machine in the group (DDC control, TA control and TF control are mixed)	Indoor unit	
L24	L24	01: Duplication of Flow Selector unit address 02: Indoor unit operation mode priority setting	○	○	○	SIM	Flow Selector unit setting trouble	I/F	
L28	L28	–	○	○	○	SIM	Too many outdoor units connected	I/F	
L29	L29	*1 Inverter quantity information	○	○	○	SIM	No. of inverter trouble	I/F	
L30	L30	Detected indoor unit address	○	○	○	SIM	Indoor unit outside interlock	Indoor unit	
–	L31	–	–	–	–		Extended I/C trouble	I/F	

Check code			Wireless remote controller				Check code name	Judging device
Wired remote controller display	Outdoor unit 7-segment display		Sensor block display of receiving unit					
		Auxiliary code	Operation	Timer	Ready	Flash		
P01	–	–	●	□	□	ALT	Indoor fan motor trouble	Indoor unit
P03	P03	–	□	●	□	ALT	Discharge temp. TD1 trouble	I/F
P04	P04	1* : Comp. 1 side 2* : Comp. 2 side	□	●	□	ALT	High-pressure SW system operation	Inverter
P05	P05	1* : Comp. 1 side 2* : Comp. 2 side	□	●	□	ALT	Phase missing detection/Power failure detection Inverter DC voltage trouble (comp.)	I/F
P07	P07	1* : Comp. 1 side 2* : Comp. 2 side 04: Heat sink	□	●	□	ALT	Heat sink overheat trouble Heat sink dew condensation trouble	Inverter, I/F
P10	P10	Detected indoor unit address	●	□	□	ALT	Indoor unit overflow trouble	Indoor unit
P11	P11	–	●	□	□	ALT	Outdoor heat exchanger freezing trouble	I/F
P12	–	–	●	□	□	ALT	Indoor unit fan motor trouble	Indoor unit
P13	P13	–	●	□	□	ALT	Outdoor liquid back detection trouble	I/F
P15	P15	01: TS condition 02: TD condition	□	●	□	ALT	Gas leak detection	I/F
P16	P16	01: PMV5 02: PMV6 03: SV7	□	●	□	ALT	Injection circuit trouble	I/F
P17	P17	–	□	●	□	ALT	Discharge temp. TD2 trouble	I/F
P18	P18	–	□	●	□	ALT	Discharge temp. TD3 trouble	I/F
P19	P19	0#: 4-way valves 1#: 4-way valve1 2#: 4-way valve2 * Put in outdoor unit No. in [#] mark.	□	●	□	ALT	4-way valve inverse trouble	I/F
P20	P20	–	□	●	□	ALT	High-pressure protective operation	I/F
P22	P22	1* : Compressor 1 side 2* : Compressor 2 side	□	●	□	ALT	Outdoor unit fan inverter trouble	Inverter
P26	P26	1* : Comp. 1 side 2* : Comp. 2 side	□	●	□	ALT	IPM short protection trouble	Inverter
P29	P29	1* : Comp. 1 side 2* : Comp. 2 side	□	●	□	ALT	Comp. position detective circuit system trouble	Inverter
P31	–	–	□	●	□	ALT	Other indoor unit trouble (Group follower indoor unit trouble)	Indoor unit

- For details about check codes determined with an Interface P.C. Board or an Inverter P.C. Board, refer to the Installation Manual of the outdoor unit.

***1 Inverter quantity information**
(Super Modular Multi System e and u series (SMMS-e, SMMS-u, SHRM-A))

No.	Comp. Inverter		Fan Inverter		Trouble
	1	2	1	2	
01	○				Comp. 1
02		○			Comp. 2
03	○	○			Comp. 1 + Comp. 2
08			○		Fan 1
09	○		○		Comp. 1 + Fan 1
0A		○	○		Comp. 2 + Fan 1
0B	○	○	○		Comp. 1 + Comp. 2 + Fan 1
10				○	Fan 2
11	○			○	Comp. 1 + Fan 2
12		○		○	Comp. 2 + Fan 2
13	○	○		○	Comp. 1 + Comp. 2 + Fan 2
18			○	○	Fan 1 + Fan 2
19	○		○	○	Comp. 1 + Fan 1 + Fan 2
1A		○	○	○	Comp. 2 + Fan 1 + Fan 2
1B	○	○	○	○	All

○ : Inverter trouble

Trouble detected by central control device

Central control device indication	Check code		Wireless remote controller				Check code name	Judging device
	Outdoor unit 7-segment display		Sensor block display of receiving unit					
		Auxiliary code	Operation	Timer	Ready	Flash		
C05	-	-			-		Sending trouble in central control device	Central control device
C06	-	-			-		Receiving trouble in central control device	Central control device
C12	-	-			-		Batch alarm of general-purpose equipment control interface	General-purpose equipment I/F
P30 (L20)	Differs according to trouble contents of unit with occurrence of alarm						Group control follower unit trouble	Central control device
	-	-	(L20 is displayed.)				<ul style="list-style-type: none"> • Duplication addresses of indoor units in central control device • With the combination of air conditioning system, the indoor unit may detect the check code of L20 	
S01	-	-			-		Receiving trouble in central control device	Central control device

13 SPECIFICATIONS

Model	Sound pressure level (dBA)		Weight (kg)
	Cooling	Heating	
MMK-UP0051DHPL-E	*	*	12
MMK-UP0071DHPL-E	*	*	12
MMK-UP0091DHPL-E	*	*	12
MMK-UP0121DHPL-E	*	*	12
MMK-UP0151DHPL-E	*	*	12
MMK-UP0181DHPL-E	*	*	12

* Under 70 dBA

14 NOTICE CODE

- Notice code is a function only in TC2U-Link communication.
- When the outdoor or indoor unit detects its conditions requiring caution or maintenance, this function notices you to check your units with the spanner mark (Notice code mark) on the wired remote controller or central controller display.
- Even while the notice code mark is displayed, the air conditioner can operate normally.
- A maximum of 5 notice codes can be issued simultaneously in one system (line).

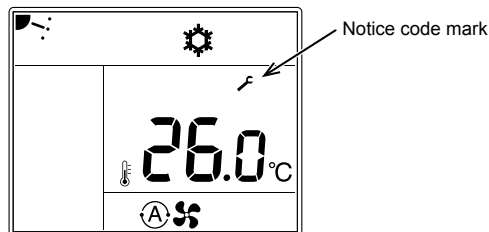

■ How to check Notice code No.

- 1 Stop the operation of the air conditioner and push the Menu button and OFF timer button at the same time for 10 seconds or more.
- 2 The unit number of the indoor unit is displayed at the bottom left of the screen. Change it with the [▽] [△] setting button and push the OFF timer button to confirm.
- 3 The history number is displayed in the center of the screen, and the Notice code No. is displayed in the lower left. [▽] [△] You can switch the history with the setting button (a maximum of 5 notice codes).
- 4 Push the ON / OFF button to return to the operation stop screen.

■ Notice code list

Notice code No.	Item	Content
203	Flow Selector unit battery dead	The battery kit connected to the Flow Selector unit has reached the end of its life.
204	Leak detector life advance display	The leak detector will soon reach the end of its life.

Declaration of Conformity

Manufacturer: CARRIER AIR CONDITIONING (THAILAND) CO., LTD.
144/9 MOO 5, BANGKADI INDUSTRIAL PARK, TIVANON ROAD,
TAMBOL BANGKADI, AMPHUR MUANGPATHUMTHANI,
PATHUMTHANI 12000, THAILAND

TCF holder: Carrier RLC Europe S.A.S
Immeuble Le Cristalia 3 rue Joseph Monier
92500 Rueil-Malmaison FRANCE

Hereby declares that the machinery described below:

Generic Denomination: Air Conditioner

Model / type: MMK-UP0051DHPL-E, MMK-UP0121DHPL-E
MMK-UP0071DHPL-E, MMK-UP0151DHPL-E
MMK-UP0091DHPL-E, MMK-UP0181DHPL-E

Commercial name: Super Modular Multi System Air Conditioner
Super Heat Recovery Multi System Air Conditioner
Mini-Super Modular Multi System Air Conditioner (MiNi-SMMS series)

Complies with the provisions of the Machinery Directive (Directive 2006/42/EC) and the regulations transposing into national law

Name: Kazunari Watanabe
Position: GM, Quality Assurance Dept.
Date: 2 May, 2024
Place Issued: Thailand

NOTE

This declaration becomes invalid if technical or operational modifications are introduced without the manufacturer's consent.

Declaration of Conformity

Manufacturer: CARRIER AIR CONDITIONING (THAILAND) CO., LTD.
144/9 MOO 5, BANGKADI INDUSTRIAL PARK, TIVANON ROAD,
TAMBOL BANGKADI, AMPHUR MUANGPATHUMTHANI,
PATHUMTHANI 12000, THAILAND

TCF holder: Carrier Solutions UK Ltd.
Porsham Close, Belliver Industrial Estate,
PLYMOUTH, Devon,
PL6 7DB, United Kingdom

Hereby declares that the machinery described below:

Generic Denomination: Air Conditioner

Model / type: MMK-UP0051DHPL-E, MMK-UP0121DHPL-E
MMK-UP0071DHPL-E, MMK-UP0151DHPL-E
MMK-UP0091DHPL-E, MMK-UP0181DHPL-E

Commercial name: Super Modular Multi System Air Conditioner
Super Heat Recovery Multi System Air Conditioner
Mini-Super Modular Multi System Air Conditioner (MiNi-SMMS series)

Complies with the provisions of the Supply of Machinery (Safety) Regulations 2008

Name: Kazunari Watanabe
Position: GM, Quality Assurance Dept.
Date: 2 May, 2024
Place Issued: Thailand

NOTE

This declaration becomes invalid if technical or operational modifications are introduced without the manufacturer's consent.

15 APPENDIX

Work instructions

The existing R22 and R410A piping can be reused for inverter R32 product installations.

WARNING

Confirming the existence of scratches or dents on the existing pipes and confirming the reliability of the pipe strength are conventionally referred to the local site. If the specified conditions can be cleared, it is possible to update existing R22 and R410A pipes to those for R32 models.

Basic conditions needed to reuse existing pipes

Check and observe the presence of three conditions in the refrigerant piping works.

1. **Dry** (There is no moisture inside of the pipes.)
2. **Clean** (There is no dust inside of the pipes.)
3. **Tight** (There are no refrigerant leaks.)

Restrictions for use of existing pipes

In the following cases, the existing pipes should not be reused as they are. Clean the existing pipes or exchange them with new pipes.

1. When a scratch or dent is heavy, be sure to use new pipes for the refrigerant piping works.
2. When the existing pipe thickness is thinner than the specified "Pipe diameter and thickness," be sure to use new pipes for the refrigerant piping works.
 - The operating pressure of refrigerant is high. If there is a scratch or dent on the pipe or a thinner pipe is used, the pressure strength may be inadequate, which may cause the pipe to break in the worst case.

* Pipe diameter and thickness (mm)

Pipe outer diameter		Ø6.4	Ø9.5	Ø12.7	Ø15.9
Thickness	R32, R410A	0.8	0.8	0.8	1.0
	R22				

3. When the outdoor unit was left with the pipes disconnected, or the gas leaked from the pipes and the pipes were not repaired and refilled.
 - There is the possibility of rain water or air, including moisture, entering the pipe.
4. When refrigerant cannot be recovered using a refrigerant recovery unit.
 - There is the possibility that a large quantity of dirty oil or moisture remains inside the pipes.

5. When a commercially available dryer is attached to the existing pipes.
 - There is the possibility that copper green rust has been generated.
6. When the existing air conditioner is removed after refrigerant has been recovered. Check if the oil is judged to be clearly different from normal oil.
 - The refrigerator oil is copper rust green in color:

There is the possibility that moisture has mixed with the oil and rust has been generated inside the pipe.
 - There is discolored oil, a large quantity of residue, or a bad smell.
 - A large quantity of shiny metal dust or other wear residue can be seen in the refrigerant oil.
7. When the air conditioner has a history of the compressor failing and being replaced.
 - When discolored oil, a large quantity of residue, shiny metal dust, or other wear residue or mixture of foreign matter is observed, trouble will occur.
8. When temporary installation and removal of the air conditioner are repeated such as when leased etc.
9. If the type of refrigerator oil of the existing air conditioner is other than the following oil (Mineral oil), Suniso, Freol-S, MS (Synthetic oil), alkyl benzene (HAB, Barrel-freeze), ester series, PVE only of ether series.
 - The winding-insulation of the compressor may deteriorate.

NOTE

The above descriptions are results have been confirmed by our company and represent our views on our air conditioners, but do not guarantee the use of the existing pipes of air conditioners that have adopted R32, R410A in other companies.

Curing of pipes

When removing and opening the indoor or outdoor unit for a long time, cure the pipes as follows:

- Otherwise rust may be generated when moisture or foreign matter due to condensation enters the pipes.
- The rust cannot be removed by cleaning, and new pipes are necessary.

Placement location	Term	Curing manner
Outdoors	1 month or more	Pinching
	Less than 1 month	Pinching or taping
Indoors	Every time	

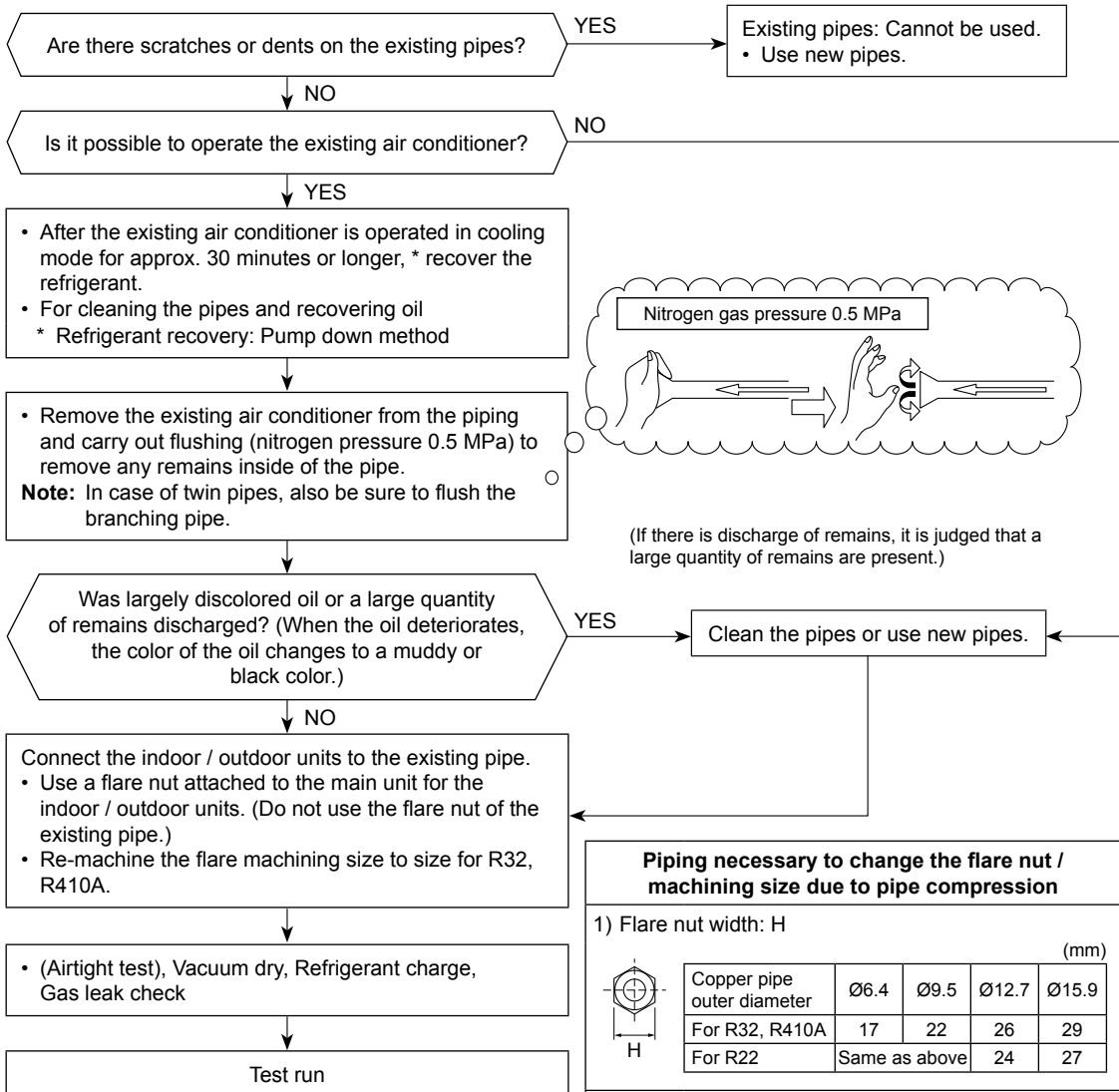

Piping necessary to change the flare nut / machining size due to pipe compression

1) Flare nut width: H (mm)

Copper pipe outer diameter	Ø6.4	Ø9.5	Ø12.7	Ø15.9
For R32, R410A	17	22	26	29
For R22	Same as above		24	27

2) Flare machining size: A (mm)

Copper pipe outer diameter	Ø6.4	Ø9.5	Ø12.7	Ø15.9
For R32, R410A	9.1	13.2	16.6	19.7
For R22	9.0	13.0	16.2	19.4

Becomes a little larger for R32, R410A

Do not apply refrigerator oil to the flare surface.

WARNINGS ON REFRIGERANT LEAKAGE

Check of Concentration Limit

The room in which the air conditioner is to be installed requires a design that in the event of refrigerant gas leaking out, its concentration will not exceed a set limit.

The refrigerant R32 or R410A which is used in the air conditioner is safe, without the toxicity or combustibility of ammonia, and is not restricted by laws to be imposed which protect the ozone layer. However, since it contains more than air, it poses the risk of suffocation if its concentration should rise excessively. Suffocation from leakage of R32 or R410A is almost non-existent. With the recent increase in the number of high concentration buildings, however, the installation of multi air conditioner systems is on the increase because of the need for effective use of floor space, individual control, energy conservation by curtailing heat and carrying power etc.

Most importantly, the multi air conditioner system is able to replenish a large amount of refrigerant compared with conventional individual air conditioners. If a single unit of the multi conditioner system is to be installed in a small room, select a suitable model and installation procedure so that if the refrigerant accidentally leaks out, its concentration does not reach the limit (and in the event of an emergency, measures can be made before injury can occur).

In a room where the concentration may exceed the limit, create an opening with adjacent rooms, or install mechanical ventilation combined with a gas leak detection device.

The concentration is as given below.

$$\frac{\text{Total amount of refrigerant (kg)}}{\text{Min. volume of the indoor unit installed room (m}^3\text{)}} \leq \text{Concentration limit (kg/m}^3\text{)}$$

The concentration limit of R32 or R410A which is used in multi air conditioners is 0.3 kg/m³.

▼ NOTE 1

If there are 2 or more refrigerating systems in a single refrigerating device, the amounts of refrigerant should be as charged in each independent device.

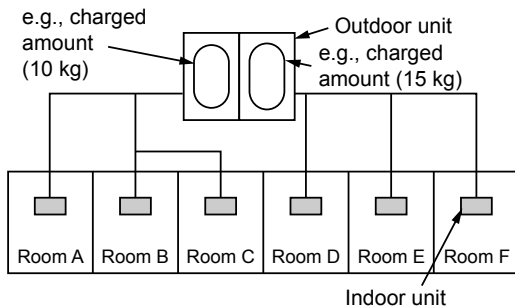

For the amount of charge in this example:

The possible amount of leaked refrigerant gas in rooms A, B and C is 10 kg.

The possible amount of leaked refrigerant gas in rooms D, E and F is 15 kg.

▼ NOTE 2

The standards for minimum room volume are as follows.

(1) No partition (shaded portion)

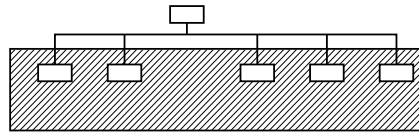

(2) When there is an effective opening with the adjacent room for ventilation of leaking refrigerant gas (opening without a door, or an opening 0.15% or larger than the respective floor spaces at the top or bottom of the door).

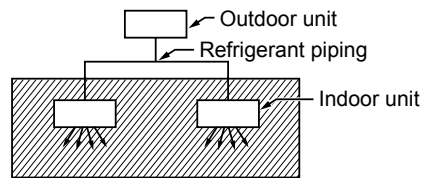

(3) If an indoor unit is installed in each partitioned room and the refrigerant piping is interconnected, the smallest room of course becomes the object. But when a mechanical ventilation is installed interlocked with a gas leakage detector in the smallest room where the density limit is exceeded, the volume of the next smallest room becomes the object.

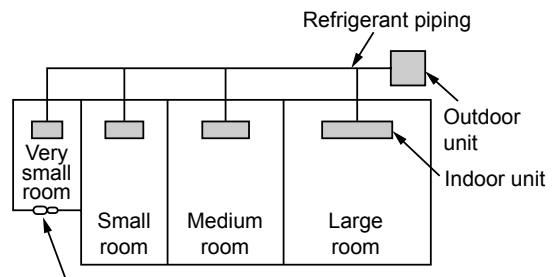

Mechanical ventilation device - Gas leak detector

▼ NOTE 3

The minimum indoor floor area compared with the amount of refrigerant is roughly as follows: (When the ceiling is 2.7 m high)

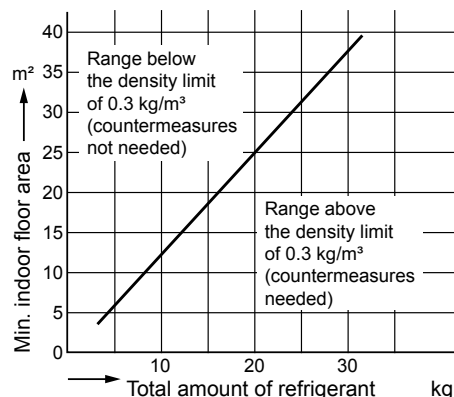

CONFIRMATION OF INDOOR UNIT SETUP

Prior to delivery to the customer, check the address and setup of the indoor unit, which has been installed in this time and fill the check sheet (Table below). Data of four units can be entered in this check sheet. Copy this sheet according to the No. of the indoor units. If the installed system is a group control system, use this sheet by entering each line system into each Installation Manual attached to the other indoor units.

REQUIREMENT

This check sheet is required for maintenance after installation. Be sure to fill this sheet and then pass this Installation Manual to the customers.

Indoor unit setup check sheet

Indoor unit			Indoor unit			Indoor unit			Indoor unit		
Room name			Room name			Room name			Room name		
Model			Model			Model			Model		
Check indoor unit address. (For check method, refer to Applicable controls in this sheet.)											
* In case of a single system, it is unnecessary to enter the indoor address. (CODE No.: Line [12], Indoor [13], Group [14], Central control [03])											
Line	Indoor	Group	Line	Indoor	Group	Line	Indoor	Group	Line	Indoor	Group
Central control address			Central control address			Central control address			Central control address		
Various setup			Various setup			Various setup			Various setup		
Have you changed high ceiling setup? If not, fill check mark [x] in [NO CHANGE], and fill check mark [x] in [ITEM] if changed, respectively. (For check method, refer to Applicable controls in this sheet.) * In case of replacement of short plugs on indoor microcomputer P.C. Board, setup is automatically changed.											
High ceiling setup (CODE No. [5d]) <input type="checkbox"/> NO CHANGE <input type="checkbox"/> STANDARD [0000] <input type="checkbox"/> HIGH CEILING 1 [0001] <input type="checkbox"/> HIGH CEILING 3 [0003]			High ceiling setup (CODE No. [5d]) <input type="checkbox"/> NO CHANGE <input type="checkbox"/> STANDARD [0000] <input type="checkbox"/> HIGH CEILING 1 [0001] <input type="checkbox"/> HIGH CEILING 3 [0003]			High ceiling setup (CODE No. [5d]) <input type="checkbox"/> NO CHANGE <input type="checkbox"/> STANDARD [0000] <input type="checkbox"/> HIGH CEILING 1 [0001] <input type="checkbox"/> HIGH CEILING 3 [0003]			High ceiling setup (CODE No. [5d]) <input type="checkbox"/> NO CHANGE <input type="checkbox"/> STANDARD [0000] <input type="checkbox"/> HIGH CEILING 1 [0001] <input type="checkbox"/> HIGH CEILING 3 [0003]		
Have you changed lighting time of filter sign? If not, fill check mark [x] in [NO CHANGE], and fill check mark [x] in [ITEM] if changed, respectively. (For check method, refer to Applicable controls in this sheet.)											
Filter sign lighting time (CODE No. [01]) <input type="checkbox"/> NO CHANGE <input type="checkbox"/> NONE [0000] <input type="checkbox"/> 150H [0001] <input type="checkbox"/> 2500H [0002] <input type="checkbox"/> 5000H [0003] <input type="checkbox"/> 10000H [0004]			Filter sign lighting time (CODE No. [01]) <input type="checkbox"/> NO CHANGE <input type="checkbox"/> NONE [0000] <input type="checkbox"/> 150H [0001] <input type="checkbox"/> 2500H [0002] <input type="checkbox"/> 5000H [0003] <input type="checkbox"/> 10000H [0004]			Filter sign lighting time (CODE No. [01]) <input type="checkbox"/> NO CHANGE <input type="checkbox"/> NONE [0000] <input type="checkbox"/> 150H [0001] <input type="checkbox"/> 2500H [0002] <input type="checkbox"/> 5000H [0003] <input type="checkbox"/> 10000H [0004]			Filter sign lighting time (CODE No. [01]) <input type="checkbox"/> NO CHANGE <input type="checkbox"/> NONE [0000] <input type="checkbox"/> 150H [0001] <input type="checkbox"/> 2500H [0002] <input type="checkbox"/> 5000H [0003] <input type="checkbox"/> 10000H [0004]		
Have you changed detected temp. shift value? If not, fill check mark [x] in [NO CHANGE], and fill check mark [x] in [ITEM] if changed, respectively. (For check method, refer to Applicable control in this sheet.)											
Detected temp. shift value setup (CODE No. [06]) <input type="checkbox"/> NO CHANGE <input type="checkbox"/> NO SHIFT [0000] <input type="checkbox"/> +1°C [0001] <input type="checkbox"/> +2°C [0002] <input type="checkbox"/> +3°C [0003] <input type="checkbox"/> +4°C [0004] <input type="checkbox"/> +5°C [0005] <input type="checkbox"/> +6°C [0006]			Detected temp. shift value setup (CODE No. [06]) <input type="checkbox"/> NO CHANGE <input type="checkbox"/> NO SHIFT [0000] <input type="checkbox"/> +1°C [0001] <input type="checkbox"/> +2°C [0002] <input type="checkbox"/> +3°C [0003] <input type="checkbox"/> +4°C [0004] <input type="checkbox"/> +5°C [0005] <input type="checkbox"/> +6°C [0006]			Detected temp. shift value setup (CODE No. [06]) <input type="checkbox"/> NO CHANGE <input type="checkbox"/> NO SHIFT [0000] <input type="checkbox"/> +1°C [0001] <input type="checkbox"/> +2°C [0002] <input type="checkbox"/> +3°C [0003] <input type="checkbox"/> +4°C [0004] <input type="checkbox"/> +5°C [0005] <input type="checkbox"/> +6°C [0006]			Detected temp. shift value setup (CODE No. [06]) <input type="checkbox"/> NO CHANGE <input type="checkbox"/> NO SHIFT [0000] <input type="checkbox"/> +1°C [0001] <input type="checkbox"/> +2°C [0002] <input type="checkbox"/> +3°C [0003] <input type="checkbox"/> +4°C [0004] <input type="checkbox"/> +5°C [0005] <input type="checkbox"/> +6°C [0006]		
Incorporation of parts sold separately			Incorporation of parts sold separately			Incorporation of parts sold separately			Incorporation of parts sold separately		
Have you incorporated the following parts sold separately? If incorporated, fill check mark [x] in each [ITEM]. (When incorporating, the setup change is necessary in some cases. For setup change method, refer to Installation Manual attached to each part sold separately.)											
Panel <input type="checkbox"/> Standard panel			Panel <input type="checkbox"/> Standard panel			Panel <input type="checkbox"/> Standard panel			Panel <input type="checkbox"/> Standard panel		
Filter <input type="checkbox"/> Super long life filter			Filter <input type="checkbox"/> Super long life filter			Filter <input type="checkbox"/> Super long life filter			Filter <input type="checkbox"/> Super long life filter		
<input type="checkbox"/> Others ()			<input type="checkbox"/> Others ()			<input type="checkbox"/> Others ()			<input type="checkbox"/> Others ()		
<input type="checkbox"/> Others ()			<input type="checkbox"/> Others ()			<input type="checkbox"/> Others ()			<input type="checkbox"/> Others ()		

CARRIER AIR CONDITIONING (THAILAND) CO., LTD.

144/9 MOO 5, BANGKADI INDUSTRIAL PARK, TIVANON ROAD, TAMBOL BANGKADI, AMPHUR MUANGPATHUMTHANI, PATHUMTHANI 12000, THAILAND

1133850103-1A