

TOSHIBA

HOT WATER MODULE (MULTI TYPE)
Installation Manual

R32 or R410A

For commercial use

Indoor Unit

Model name:

<Mid temperature Hot Water Module>

MMW-UP0271LQ-E

MMW-UP0561LQ-E

Original instruction

Please read this Installation Manual carefully before installing the hot water module.

- This Manual describes the installation method of the hot water module.
- Also read the Installation Manual that come with the outdoor unit and optional parts.

ADOPTION OF R32 OR R410A REFRIGERANT

This hot water module has adopted a refrigerant HFC (R32 or R410A) which does not destroy the ozone layer. Be sure to check the refrigerant type for outdoor unit to be combined, and then install it.

When combining with an outdoor unit of R32 refrigerant, it is legally necessary to connect a refrigerant leak detection system. Contact your dealer or contractor for more information on the system. To check the type of refrigerant used, refer to the outdoor unit Installation Manual.

Information

If U series models (TU2C-Link) are combined with models other than U series (TCC-Link), the wiring specifications and maximum number of connect-able indoor units will be changed. Pay attentions to their communication specifications when carrying out the installation, maintenance, or repair. For its details, refer to the “**Electrical connection**” in this Manual.

Contents

1	Precautions for safety	3
2	Accessory parts	12
3	System control of Hot Water Module	13
4	Selection of installation place	24
5	Installation	25
6	Water piping	27
7	Drain piping	30
8	Refrigerant piping	31
9	Electrical connection	33
10	Applicable controls	39
11	Test run	40
12	Maintenance	41
13	Troubleshooting	41
14	Notice code	46

Thank you for purchasing this Toshiba Hot Water Module.

Please read carefully through these instructions that contain important information, and ensure that you understand them.

After completing the installation work, hand over this Installation Manual and Owner's Manual as well as the Owner's Manual provided with the outdoor unit to the user, and ask the user to keep them in a safe place for future reference.

Generic Denomination: Hot Water Module

Definition of Qualified Installer or Qualified Service Person

The hot water module must be installed, maintained, repaired and removed by a qualified installer or qualified service person. When any of these jobs is to be done, ask a qualified installer or qualified service person to do them.

A qualified installer or qualified service person is an agent who has the qualifications and knowledge described in the table below.

Agent	Qualifications and knowledge which the agent must have
Qualified installer (*1)	<ul style="list-style-type: none"> The qualified installer is a person who installs, maintains, relocates and removes the air conditioners (including the hot water modules) made by Carrier Japan Corporation. He or she has been trained to install, maintain, relocate and remove the air conditioners (including the hot water modules) made by Carrier Japan Corporation or, alternatively, he or she has been instructed in such operations by an individual or individuals who have been trained and is thus thoroughly acquainted with the knowledge related to these operations. The qualified installer who is allowed to do the electrical work involved in installation, relocation and removal has the qualifications pertaining to this electrical work as stipulated by the local laws and regulations, and he or she is a person who has been trained in matters relating to electrical work on the air conditioners (including the hot water modules) made by Carrier Japan Corporation or, alternatively, he or she has been instructed in such matters by an individual or individuals who have been trained and is thus thoroughly acquainted with the knowledge related to this work. The qualified installer who is allowed to do the refrigerant handling and piping work involved in installation, relocation and removal has the qualifications pertaining to this refrigerant handling and piping work as stipulated by the local laws and regulations, and he or she is a person who has been trained in matters relating to refrigerant handling and piping work on the air conditioners (including the hot water modules) made by Carrier Japan Corporation or, alternatively, he or she has been instructed in such matters by an individual or individuals who have been trained and is thus thoroughly acquainted with the knowledge related to this work. The qualified installer who is allowed to work at heights has been trained in matters relating to working at heights with the air conditioners (including the hot water modules) made by Carrier Japan Corporation or, alternatively, he or she has been instructed in such matters by an individual or individuals who have been trained and is thus thoroughly acquainted with the knowledge related to this work.
Qualified service person (*1)	<ul style="list-style-type: none"> The qualified service person is a person who installs, repairs, maintains, relocates and removes the air conditioners (including the hot water modules) made by Carrier Japan Corporation. He or she has been trained to install, repair, maintain, relocate and remove the air conditioners (including the hot water modules) made by Carrier Japan Corporation or, alternatively, he or she has been instructed in such operations by an individual or individuals who have been trained and is thus thoroughly acquainted with the knowledge related to these operations. The qualified service person who is allowed to do the electrical work involved in installation, repair, relocation and removal has the qualifications pertaining to this electrical work as stipulated by the local laws and regulations, and he or she is a person who has been trained in matters relating to electrical work on the air conditioners (including the hot water modules) made by Carrier Japan Corporation or, alternatively, he or she has been instructed in such matters by an individual or individuals who have been trained and is thus thoroughly acquainted with the knowledge related to this work. The qualified service person who is allowed to do the refrigerant handling and piping work involved in installation, repair, relocation and removal has the qualifications pertaining to this refrigerant handling and piping work as stipulated by the local laws and regulations, and he or she is a person who has been trained in matters relating to refrigerant handling and piping work on the air conditioners (including the hot water modules) made by Carrier Japan Corporation or, alternatively, he or she has been instructed in such matters by an individual or individuals who have been trained and is thus thoroughly acquainted with the knowledge related to this work. The qualified service person who is allowed to work at heights has been trained in matters relating to working at heights with the air conditioners (including the hot water modules) made by Carrier Japan Corporation or, alternatively, he or she has been instructed in such matters by an individual or individuals who have been trained and is thus thoroughly acquainted with the knowledge related to this work.

Definition of Protective Gear



When the hot water module is to be transported, installed, maintained, repaired or removed, wear protective gloves and 'safety' work clothing.

In addition to such normal protective gear, wear the protective gear described below when undertaking the special work detailed in the table below.

Failure to wear the proper protective gear is dangerous because you will be more susceptible to injury, burns, electric shocks and other injuries.

Work undertaken	Protective gear worn
All types of work	Protective gloves 'Safety' working clothing
Electrical-related work	Clothing to provide protection from electric shock Insulating shoes Gloves to provide protection from electric shock
Work done at heights (50 cm or more)	Helmets for use in industry
Transportation of heavy objects	Shoes with additional protective toecap
Repair of outdoor unit	Gloves to provide protection for electricians

These safety cautions describe important matters concerning safety to prevent injury to users or other people and damages to property. Please read through this manual after understanding the contents below (meanings of indications), and be sure to follow the description.

Indication	Meaning of Indication
 WARNING	Text set off in this manner indicates that failure to adhere to the directions in the warning could result in serious bodily harm (1) or loss of life if the product is handled improperly.
 CAUTION	Text set off in this manner indicates that failure to adhere to the directions in the caution could result in slight injury (2) or damage (3) to property if the product is handled improperly.
	<ol style="list-style-type: none"> Serious bodily harm indicates loss of eyesight, injury, burns, electric shock, bone fracture, poisoning, and other injuries which leave aftereffect and require hospitalization or long-term treatment as an outpatient. Slight injury indicates injury, burns, electric shock, and other injuries which do not require hospitalization or long-term treatment as an outpatient. Damage to property indicates damage extending to buildings, household effects, domestic livestock, and pets.

1 Precautions for safety

The manufacturer shall not assume any liability for the damage caused by not observing the description of this manual.

When connecting to an outdoor unit that uses R32 refrigerant, be sure to read the warnings and cautions in “Precautions for using R32 refrigerant”.

WARNING

General

- Before starting to install the hot water module, read through the Installation Manual carefully, and follow its instructions to install the hot water module.
- Only a qualified installer or service person is allowed to do installation work. Inappropriate installation may result in water leakage, electric shock or fire.
- Do not use any refrigerant different from the one specified for complement or replacement. Otherwise, abnormally high pressure may be generated in the refrigeration cycle, which may result in a failure or explosion of the product or an injury to your body.
- Before opening the front panel of the hot water module or service panel of the outdoor unit, set the circuit breaker to the OFF position. Failure to set the circuit breaker to the OFF position may result in electric shocks through contact with the interior parts. Only a qualified installer (*1) or qualified service person (*1) is allowed to remove the front panel of the hot water module or service panel of the outdoor unit and do the work required.
- Before carrying out the installation, maintenance, repair or removal work, set the circuit breaker to the OFF position. Otherwise, electric shocks may result.
- Place a “Work in progress” sign near the circuit breaker while the installation, maintenance, repair or removal work is being carried out. There is a danger of electric shocks if the circuit breaker is set to ON by mistake.
- Only a qualified installer (*1) or qualified service person (*1) is allowed to undertake work at heights using a stand of 50 cm or more or to remove the front panel of the hot water module to undertake work.

- Wear protective gloves and safety work clothing during installation, servicing and removal.
- Do not touch the plate heat exchanger of the unit. You may injure yourself if you do so. If the plate heat exchanger must be touched for some reason, first put on protective gloves and safety work clothing, and then proceed.
- Do not climb onto or place objects on top of the outdoor unit. You may fall or the objects may fall off of the outdoor unit and result in injury.
- When work is performed at heights, use a ladder which complies with the ISO 14122 standard, and follow the procedure in the ladder’s instructions. Also wear a helmet for use in industry as protective gear to undertake the work.
- Before other parts of the outdoor unit, set the circuit breaker to OFF without fail, and place a “Work in progress” sign near the circuit breaker before proceeding with the work.
- Before working at heights, put a sign in place so that no one will approach the work location, before proceeding with the work. Parts and other objects may fall from above, possibly injuring a person below. While carrying out the work, wear a helmet for protection from falling objects.
- The refrigerant used by this hot water module is the R32 or R410A.
- The hot water module must be transported in stable condition. If any part of the product is broken, contact the dealer.
- When the hot water module must be transported by hand, carry it by four or more people.
- Do not move or repair any unit by yourself. There is high voltage inside the unit. You may get electric shock when removing the cover and main unit.
- This appliance is intended to be used by expert or trained users in shops, in light industry, or for commercial use by lay persons.

Selection of installation location

- When the hot water module is installed in a small room, provide appropriate measures to ensure that the concentration of refrigerant leakage occur in the room does not exceed the critical level.
- Do not install in a location where flammable gas leaks are possible. If the gas leak and accumulate around the unit, it may ignite and cause a fire.
- To transport the hot water module, wear shoes with additional protective toe caps.

- To transport the hot water module, do not take hold of the bands around the packing carton. You may injure yourself if the bands should break.
- The hot water module has been designed to be fitted at floor level.

Installation

- Install the hot water module securely in a location where the base can sustain the weight adequately. If the strength is not enough, the unit may fall down resulting in injury.
- Follow the instructions in the Installation Manual to install the hot water module. Failure to follow these instructions may cause the product to fall down or topple over or give rise to noise, vibration, water leakage or other trouble.
- Carry out the specified installation work to guard against the possibility of earthquake. If the hot water module is not installed appropriately, a unit may topple over or fall down, causing an accident.
- If refrigerant gas has leaked during the installation work, ventilate the room immediately. If the leaked refrigerant gas comes in contact with fire, noxious gas may generate.
- Use forklift to carry in the hot water module units and use winch or hoist at installation of them.
- Helmet must be worn to protect your head from falling objects. Especially, when you work under an inspection opening, helmet must be worn to protect your head from falling objects from the opening.
- The unit can be accessed from the service panel.

Refrigerant piping

- Install the refrigerant pipe securely during the installation work before operating the hot water module. If the compressor is operated with the valve open and without refrigerant pipe, the compressor sucks air and the refrigeration cycles is over pressurized, which may cause a injury.
- Tighten the flare nut with a torque wrench in the specified manner. Excessive tighten of the flare nut may cause a crack in the flare nut after a long period, which may result in refrigerant leakage.
- After the installation work, confirm that refrigerant gas does not leak. If refrigerant gas leaks into the room and flows near a fire source, such as a cooking range, noxious gas may be generated.

- When the hot water module has been installed or relocated, follow the instructions in the Installation Manual and purge the air completely so that no gases other than the refrigerant will be mixed in the refrigerating cycle. Failure to purge the air completely may cause the hot water module to malfunction.
- Nitrogen gas must be used for the airtight test.
- The charge hose must be connected in such a way that it is not slack.

Water piping

- Do not install water pipes in a location that is susceptible to freezing.

Electrical wiring

- Only a qualified installer (*1) or qualified service person (*1) is allowed to carry out the electrical work of the hot water module. Under no circumstances must this work be done by an unqualified individual since failure to carry out the work properly may result in electric shocks and/or electrical leaks.
- To connect the electrical wires, repair the electrical parts or undertake other electrical jobs, wear gloves to provide protection for electricians and from heat, insulating shoes and clothing to provide protection from electric shocks. Failure to wear this protective gear may result in electric shocks.
- Use wiring that meets the specifications in the Installation Manual and the stipulations in the local regulations and laws. Use of wiring which does not meet the specifications may give rise to electric shocks, electrical leakage, smoking and/or a fire.
- Connect earth wire. (Grounding work)
Incomplete grounding causes an electric shock.
- Do not connect earth wires to gas pipes, water pipes, and lightning conductor or telephone earth wires.
- After completing the repair or relocation work, check that the earth wires are connected properly.
- Install a circuit breaker that meets the specifications in the installation manual and the stipulations in the local regulations and laws.
- Install the circuit breaker where it can be easily accessed by the agent.
- When installing the circuit breaker outdoors, install one which is designed to be used outdoors.

- Under no circumstances the power wire must not be extended. Connection trouble in the places where the wire is extended may give rise to smoking and/or a fire.
- Electrical wiring work shall be conducted according to law and regulation in the community and installation manual. Failure to do so may result in electrocution or short circuit.

Test run

- Before operating the hot water module after having completed the work, check that the electrical parts box cover (the front panel) of the hot water module and service panel of the outdoor unit are closed, and set the circuit breaker to the ON position. You may receive an electric shock if the power is turned on without first conducting these checks.
- If there is any kind of trouble (such as a check code display has appeared, smell of burning, abnormal sounds, the hot water module fails to heat or water is leaking) has occurred in the hot water module, do not touch the hot water module yourself but set the circuit breaker to the OFF position, and contact a qualified service person. Take steps to ensure that the power will not be turned on (by marking "out of service" near the circuit breaker, for instance) until qualified service person arrives. Continuing to use the hot water module in the trouble status may cause mechanical problems to escalate or result in electric shocks or other trouble.
- After the work has finished, use an insulation tester set (500 V Megger) to check the resistance is 1 MΩ or more between the charge section and the non-charge metal section (Earth section). If the resistance value is low, a disaster such as a leak or electric shock is caused at user's side.
- Upon completion of the installation work, check for refrigerant leaks and check the insulation resistance and water drainage. Then conduct a test run to check that the hot water module is operating properly.

Explanations given to user

- Upon completion of the installation work, tell the user where the circuit breaker is located. If the user does not know where the circuit breaker is, he or she will not be able to turn it off in the event that trouble has occurred in the hot water module.
- If the fan grille is damaged, do not approach the outdoor unit but set the circuit breaker to the OFF position, and contact a qualified service person (*1) to have the repairs done. Do not set the circuit breaker to the ON position until the repairs are completed.

Relocation

- Only a qualified installer (*1) or qualified service person (*1) is allowed to relocate the hot water module. It is dangerous for the hot water module to be relocated by an unqualified individual since a fire, electric shocks, injury, water leakage, noise and/or vibration may result.
- When carrying out the pump-down work shut down the compressor before disconnecting the refrigerant pipe. Disconnecting the refrigerant pipe with the service valve left open and the compressor still operating will cause air or other gas to be sucked in, raising the pressure inside the refrigeration cycle to an abnormally high level, and possibly resulting in rupture, injury or other trouble.

(*1) Refer to the "Definition of Qualified Installer or Qualified Service Person".

CAUTION

This hot water module has adopted a refrigerant HFC (R32 or R410A) which does not destroy the ozone layer.

- As the R32 or R410A refrigerant is easily affected by impurities such as moisture, oxidized film, oil, etc., due to the high pressure, be careful not to allow the moisture, dirt, existing refrigerant, refrigerating machine oil, etc., to get mixed up in the refrigeration cycle during the installation work.
- A special tool for the R32 or R410A refrigerant is required for installation.
- Use a new and clean piping materials for the connecting pipe so that moisture and dirt are not mixed together during the installation work.

To Disconnect the Appliance from Main Power Supply.

- This appliance must be connected to the main power supply by means of a switch with a contact separation of at least 3 mm.





Precautions for using R32 refrigerant

The basic installation work procedures are the same as conventional refrigerant (R410A, R22) models.

However, Please read through this manual after understanding the contents below;

These safety cautions describe important matters concerning safety to prevent injury to users or other people and damages to property. Please read through this manual after understanding the contents below (meanings of indications), and be sure to follow the description;

Meanings of symbols displayed on the unit

	<p>WARNING (Risk of fire)</p>	<p>This mark is for R32 refrigerant only. Refrigerant type is written on nameplate of outdoor unit. In case that refrigerant type is R32, this unit uses a flammable refrigerant. If refrigerant leaks and comes in contact with fire or heating part, it will create harmful gas and there is risk of fire.</p>
	<p>Read the OWNER'S MANUAL carefully before operation.</p>	
	<p>Service personnel are required to carefully read the OWNER'S MANUAL and INSTALLATION MANUAL before operation.</p>	
	<p>Further information is available in the OWNER'S MANUAL, INSTALLATION MANUAL, and the like.</p>	

WARNING

- Models that use refrigerant R32 and R410A have a different charging port thread diameter to prevent erroneous charging with refrigerant R22 and for safety.
- Do not use means to accelerate the defrosting process or to clean, other than those recommended by the manufacturer.
- The appliance shall be stored in a room without continuously operating ignition sources. (For example: open flames, an operating gas appliance or an operating electric heater.)
- Do not pierce or burn.
- Be aware that refrigerants may not contain an odor.
- The manufacturer may provide other suitable examples or may provide additional information about the refrigerant odor.

CAUTION

When a flammable refrigerant is used, all appliances shall be charged with refrigerant at the manufacturing location or charged on site as recommended by the manufacturer.

A part of an appliance that is charged on site, which requires brazing or welding in the installation shall not be shipped with a flammable refrigerant charge. Joints made in the installation between parts of the refrigerating system, with at least one part charged, shall be made in accordance with the following.

- A brazed, welded, or mechanical connection shall be made before opening the valves to permit refrigerant to flow between the refrigerating system parts. A vacuum valve shall be provided to evacuate the interconnecting pipe and/or any uncharged refrigerating system part.
- Mechanical connectors used indoors shall comply with ISO 14903. When mechanical connectors are reused indoors, sealing parts shall be renewed. When flared joints are reused indoors, the flare part shall be re-fabricated.
- Refrigerant tubing shall be protected or enclosed to avoid damage. Flexible refrigerant connectors (such as connecting lines between the indoor and outdoor unit) that may be displaced during normal operations shall be protected against mechanical damage.

General (Installation space / area)

- The installation of pipe-work shall be kept to a minimum.
- Pipe-work shall be protected from physical damage.
- The compliance with national gas regulations shall be observed.
- The mechanical connections shall be accessible for maintenance purposes.
- In cases that require mechanical ventilation, ventilation openings shall be kept clear of obstruction.
- When disposing of the product is used, be based on national regulations with properly processed.
- The servicing shall be performed only as recommended by the manufacturer.
- Where the appliance using flammable refrigerants is installed, Be aware that;
 - The appliance shall be stored in a well-ventilated area where the room size corresponds to the room area as specified for operation.
 - The appliance shall be stored in a room without continuously operating open flames (for example an operating gas appliance) and ignition sources (for example an operating electric heater).
 - The appliance shall be stored so as to prevent mechanical damage from occurring.
- Equipment piping in the occupied space shall be installed in such a way to protect against accidental damage in operation and service.
- Precautions shall be taken to avoid excessive vibration or pulsation to refrigerating piping.
- Protection devices, piping and fittings shall be protected as far as possible against adverse environmental effects, for example, the danger of water collecting and freezing in relief pipes or the accumulation of dirt and debris.
- Provision shall be made for expansion and contraction of long runs of piping.
- Piping in refrigerating systems shall be so designed and installed to minimize the likelihood hydraulic shock damaging the system.
- Solenoid valves shall be correctly positioned in the piping to avoid hydraulic shock.
- Solenoid valves shall not block in liquid refrigerant unless adequate relief is provided to the refrigerant system low pressure side.
- Steel pipes and components shall be protected against corrosion with a rustproof coating before applying any insulation.
- Flexible pipe elements shall be protected against mechanical damage, excessive stress by torsion, or other forces. They should be checked for mechanical damage annually.

- The indoor equipment and pipes shall be securely mounted and guarded such that accidental rupture of equipment cannot occur from such events as moving furniture or reconstruction activities.
- Where safety shut off valves are specified, the minimum room area may be determined based on the maximum amount of refrigerant that can be leaked as determined in Installation Manual.
- Where safety shut off valves are specified, the location of the valve in the refrigerating system relative to the occupied spaces shall be as described in Installation Manual.
- Field-made refrigerant joints indoors shall be tightness tested. The test method shall have a sensitivity of 5 grams per year of refrigerant or better under a pressure of at least 0.25 times the maximum allowable pressure. No leak shall be detected.
- The total refrigerant charge in the system cannot exceed the requirements for minimum floor area of the smallest room that is served. For minimum floor area requirements for indoor units, see the Installation and Owner's Manual of the outdoor unit.
- When connecting to an outdoor unit of R32 refrigerant, always turn on the power of the indoor unit after installation except during service in order to detect refrigerant leakage and take safety measures.

Unventilated area

- The appliance shall be stored so as to prevent mechanical damage from occurring.

Information on servicing

1. Check to the area

- Prior to beginning work on systems containing flammable refrigerants, safety checks are necessary to ensure that the risk of ignition is minimized. For repair to the refrigerating system, the precautions in item 2 to 6 shall be complied with prior to conducting work on the system.

2. Work procedure

- Work shall be undertaken under a controlled procedure so as to minimize the risk of a flammable gas or vapour being present while the work is being performed.

3. General work area

- All maintenance staff and others working in the local area shall be instructed on the nature of work being carried out.
- Work in confined spaces shall be avoided.
- The area around the workspace shall be sectioned off.
- Ensure that the conditions within the area have been made safe by control of flammable material.

4. Checking for presence of refrigerant

- The area shall be checked with an appropriate refrigerant detector prior to and during work, to ensure the technician is aware of potentially flammable atmospheres.
- Ensure that the leak detection equipment being used is suitable for use with all applicable refrigerants, i.e. non sparking, adequately sealed or intrinsically safe.

5. Presence of fire extinguisher

- If any hot work is to be conducted on the refrigeration equipment or any associated parts, appropriate fire extinguishing equipment shall be available on hand.
- Have a dry powder or CO₂ fire extinguisher adjacent to the charging area.

6. No ignition sources

- No person carrying out work in relation to a refrigeration system which involves exposing any pipe work shall use any sources of ignition in such a manner that it may lead to the risk of fire or explosion.
- All possible ignition sources including cigarette smoking, should be kept sufficiently far away from the site of installation, repairing, removing and disposal, during which refrigerant can possibly be released to the surrounding space.
- Prior to work taking place, the area around the equipment is to be surveyed to make sure that there are no flammable hazards or ignition risks. "No Smoking" signs shall be displayed.

7. Ventilated area

- Ensure that the area is in the open or that it is adequately ventilated before breaking into the system or conducting any hot work.
- A degree of ventilation shall continue during the period that the work is carried out.
- The ventilation should safely disperse any released refrigerant and preferably expel it externally into the atmosphere.

8. Checks to the refrigeration equipment

- Where electrical components are being changed, installer shall be fit for the purpose and to the correct specification.
- At all times the manufacturer's maintenance and service guidelines shall be followed. If in doubt consult the manufacturer's technical department for assistance.
- The following checks shall be applied to installations using flammable refrigerants.
 - The charge size is in accordance with the room size within which the refrigerant containing parts are installed.
 - The ventilation machinery and outlets are operating adequately and are not obstructed.
 - If an indirect refrigerating circuit is being used, the secondary circuit shall be checked for the presence of refrigerant.
 - Marking to the equipment continues to be visible and legible. Markings and signs that are illegible shall be corrected.
 - Refrigeration pipe or components are installed in a position where they are unlikely to be exposed to any substance which may corrode refrigerant containing components, unless the components are constructed of materials which are inherently resistant to being corroded or are suitably protected against being so corroded.

9. Checks to electrical devices

- Repair and maintenance to electrical components shall include initial safety checks and component inspection procedures.
- If a fault exists that could compromise safety, then no electrical supply shall be connected to the circuit until it is satisfactorily dealt with.
- If the fault cannot be corrected immediately but it is necessary to continue operation, an adequate temporary solution shall be used. This shall be reported to the owner of the equipment so all parties are advised.
- Initial safety checks shall include;
 - That capacitors are discharged to avoid possibility of sparking.
 - That there no live electrical components and wiring are exposed while charging, recovering or purging the system.
 - That there is continuity of earth bonding.

10. Repairs to sealed components

- During repairs to sealed components, all electrical supplies shall be disconnected from the equipment being worked upon prior to any removal of sealed covers, etc.

- If it is absolutely necessary to have an electrical supply to equipment during servicing, then a permanently operating form of leak detection shall be located at the most critical point to warn of a potentially hazardous situation.
- Particular attention shall be paid to the following to ensure that by working on electrical components, the casing is not altered in such a way that the level of protection is affected.
- This shall include damage to cables, excessive number of connections, terminals not made to original specification, damage to seals, incorrect fitting of glands, etc.
- Ensure that apparatus is mounted securely.
- Ensure that seals or sealing materials have not degraded to the point that they no longer serve the purpose of preventing the ingress of flammable atmospheres.
- Replacement parts shall be in accordance with the manufacturer's specifications.

NOTE

The use of silicon sealant may inhibit the effectiveness of some types of leak detection equipment. Intrinsically safe components do not have to be isolated prior to working on them.

11. Repair to intrinsically safe components

- Do not apply any permanent inductive or capacitance loads to the circuit without ensuring that this will not exceed the permissible voltage and current permitted for the equipment in use.
- Intrinsically safe components are the only types that can be worked on while live in the presence of a flammable atmosphere.
- The test apparatus shall be at the correct rating.
- Replace components only with parts specified by the manufacturer.
- Other parts may result in the ignition of refrigerant in the atmosphere from a leak.

12. Cabling

- Check that cabling will not be subject to wear, corrosion, excessive pressure, vibration, sharp edges or any other adverse environmental effects.
- Check shall also take into account the effects of aging or continual vibration from sources such as compressors or fans.

13. Detection of flammable refrigerants

- Under no circumstances shall potential sources of ignition be used in the searching for or detection of refrigerant leaks.

- A halide torch (or any other detector using a naked flame) shall not be used.
- Electronic leak detectors may be used to detect refrigerant leaks but, in the case of flammable refrigerants, the sensitivity may not be adequate, or may need re-calibration. (Detection equipment shall be calibrated in a refrigerant-free area.)
- Ensure that the detector is not a potential source of ignition and is suitable for the refrigerant used.
- Leak detection equipment shall be set at a percentage of the LFL of the refrigerant and shall be calibrated to the refrigerant employed, and the appropriate percentage of gas (25% maximum) is confirmed.
- Leak detection fluids are also suitable for use with most refrigerants but the use of detergents containing chlorine shall be avoided as the chlorine may react with the refrigerant and corrode containing chlorine.
- If a leak is suspected, all naked flames shall be removed / extinguished.
- If a leakage of refrigerant is found which requires brazing, all of the refrigerant shall be recovered from the system, or isolated (by means of shut off valves) in a part of the system remote from the leak.

14. Leak detection methods

- Electronic leak detectors shall be used to detect flammable refrigerants leak, but the sensitivity may not be adequate, or may need re-calibration. (Detection equipment shall be calibrated in a refrigerant-free area.)
- Ensure that the detector is not a potential source of ignition and is suitable for the refrigerant used.
- Leak detection equipment shall be set at a percentage of the LFL of the refrigerant and shall be calibrated to the refrigerant employed and the appropriate percentage of gas (25% maximum) is confirmed.
- Leak detection fluids are suitable for use with most refrigerants but the use of detergents containing chlorine shall be avoided as the chlorine may react with the refrigerant and corrode the copper pipe-work.
- If a leak is suspected, all naked flames shall be removed / extinguished.
- If a leakage of refrigerant is found which requires brazing, all of the refrigerant shall be recovered from the system, or isolated (by means of shut off valves) in a part of the system remote from the leak.
- Oxygen free nitrogen (OFN) shall then be purged through the system both before and during the brazing process.

15. Removal and evacuation

- When breaking into the refrigerant circuit to make repairs or for any other purpose, Conventional procedures shall be used. However, it is important that best practice is followed since flammability is a consideration.

The following procedure shall be adhered to:

- remove refrigerant;
- purge the circuit with inert gas;
- evacuate;
- purge again with inert gas;
- open the circuit by cutting or brazing;
- The refrigerant charge shall be recovered into the correct recovery cylinders.
- The system shall be “Flushed” with OFN to render the unit safe.
- This process may need to be repeated several times.
- Compressed air or oxygen shall not be used for purging refrigerant systems.
- Flushing shall be achieved by breaking the vacuum in the system with OFN and continuing to fill until the working pressure is achieved, then venting to atmosphere, and finally pulling down to a vacuum.
- This process shall be repeated until no refrigerant is within the system.
- When the final OFN charge is used, the system shall be vented down to atmospheric pressure to enable work to take place.
- This operation is absolutely vital if brazing operations on the pipe-work are to take place.
- Ensure that the outlet for the vacuum pump is not close to any ignition sources and that ventilation available.

16. Charging procedures

- In addition to conventional charging procedures, the following requirements shall be followed.
 - Ensure that contamination of different refrigerants does not occur when using charging equipment.
 - Hoses or lines shall be as short as possible to minimize the amount of refrigerant contained in them.
 - Cylinders shall be kept upright.
 - Ensure that the refrigeration system is earthed prior to charging the system with refrigerant.
 - Label the system when charging is complete (if not already).
 - Extreme care shall be taken not to overfill the refrigeration system.

- Prior to recharging the system, it shall be pressure-tested with the appropriate purging gas.
- The system shall be leak tested on completion of charging but prior to commissioning.
- A follow up leak test shall be carried out prior to leaving the site.

17. Decommissioning

- Before carrying out this procedure, it is essential that the technician is completely familiar with the equipment and all its details.
- It is recommended good practice that all refrigerants are recovered safely.
- Prior to the task being carried out, an oil and refrigerant sample shall be taken in case analysis is required to reuse of reclaimed refrigerant.
- It is essential that electrical power is available before the task is commenced.
 - a) Become familiar with the equipment and its operation.
 - b) Isolate system electrically.
 - c) Before attempting the procedure ensure that:
 - Mechanical handling equipment is available, if required, for handling refrigerant cylinders;
 - All personal protective equipment is available and being used correctly;
 - The recovery process is supervised at all times by a competent person;
 - Recovery equipment and cylinders conform to the appropriate standards.
 - d) Pump down refrigerant system, if possible.
 - e) If a vacuum is not possible, make a manifold so that refrigerant can be removed from various parts of the system.
 - f) Make sure that cylinder is situated on the scales before recovery takes place.
 - g) Start the recovery machine and operate in accordance with manufacturer's instructions.
 - h) Do not overfill cylinders. (No more than 80% volume liquid charge.)
 - i) Do not exceed the maximum working pressure of the cylinder, even temporarily.
 - j) When the cylinders have been filled correctly and the process completed, make sure that the cylinders and the equipment are removed from site promptly and all isolation valves on the equipment are closed off.
 - k) Recovered refrigerant shall not be charged into another refrigeration system unless it has been cleaned and checked.

18. Labelling



- Equipment shall be labelled stating that it has been decommissioned and emptied of refrigerant.
- The label shall be dated and signed.
- Ensure that there are labels on the equipment stating the equipment contains flammable refrigerant.

19. Recovery

- When removing refrigerant from a system, either for servicing or decommissioning, it is recommended good practice that all refrigerants are removed safely.
- When transferring refrigerant into cylinders, ensure that only appropriate refrigerant recovery cylinders are employed.
- Ensure that the correct number of cylinders for holding the total system charge are available.
- All cylinders to be used are designated for the recovered refrigerant and labelled for that refrigerant (i.e. special cylinders for the recovery of refrigerant).
- Cylinders shall be complete with pressure-relief valve and associated shut-off valves in good working order.
- Empty recovery cylinders are evacuated and, if possible, cooled before recovery occurs.
- The recovery equipment shall be in good working order with a set of instructions concerning the equipment that is at hand and shall be suitable for the recovery of all appropriated refrigerants.
- In addition, a set of calibrated weighing scales shall be available and in good working order.
- Hoses shall be complete with leak-free disconnect couplings and in good condition.
- Before using the recovery machine, check that it is in satisfactory working order, has been properly maintained and that any associated electrical components are sealed to prevent ignition in the event of a refrigerant release.
- Consult manufacturer if in doubt.
- The recovered refrigerant shall be returned to the refrigerant supplier in the correct recovery cylinder, and the relevant waste transfer note arranged.
- Do not mix refrigerants in recovery units and especially not in cylinders.
- If compressors or compressor oils are to be removed, ensure that they have been evacuated to an acceptable level to make certain that flammable refrigerant does not remain within the lubricant.

- The evacuation process shall be carried out prior to returning the compressor to the suppliers.
 - Only electric heating to the compressor body shall be employed to accelerate this process.
 - When oil is drained from a system, it shall be carried out safely.
-

■ Warning indications on the hot water module

Warning indication		Description
	WARNING ELECTRICAL SHOCK HAZARD Disconnect all remote electric power supplies before servicing.	WARNING ELECTRICAL SHOCK HAZARD Disconnect all remote electric power supplies before servicing.
	CAUTION High temperature parts. You might get burnt when removing this panel.	CAUTION High temperature parts. You might get burned when removing this panel.

CAUTION

- This is the part for transportation. Be sure to remove this part before operating the unit.
- To avoid water leak, wrap some sealing tape around the screw part.
- Do not operate VRF system before the commissioning of this product is fully completed. Failure to do so will result in water freezing and bursting/failure of the plate heat exchanger.

2 Accessory parts

Part name	Qty	Shape	Usage
Installation Manual	1	This manual	Hand over to customers (For other languages that do not appear in this Installation Manual, please refer to the enclosed CD-ROM.)
Owner's Manual	1	—	Hand over to customers (For other languages that do not appear in the Owner's Manual, please refer to the enclosed CD-ROM.)
CD-ROM	1	—	Installation Manual, Owner's Manual
Heat insulator	1		For heat insulation of Gas pipe connecting section
	1		For heat insulation of Liquid pipe connecting section

3 System control of Hot Water Module

3.1 System able to be combined for SMMS-e, SMMS-u, SHRM-e and SHRM-A (MMY-***)

The Mid temperature Hot water module (M-HWM) is connectable to SMMS-e, SMMS-u, SHRM-e and SHRM-A.

In case of connecting at least one Hot water module in SHRM-e and SHRM-A system, all of Flow Selector unit type should be Single port type Flow Selector unit (long piping model) or Multi port type Flow Selector unit.

The Fresh Air intake type and Air to Air Heat Exchanger with DX Coil cannot be connected with the same refrigerant system.

M-HWM: Mid temperature Hot water module

H-HWM: High temperature Hot water module

HWM: Mid temperature Hot water module and High temperature Hot water module

No.	Item		SMMS-e	SMMS-u	SHRM-e	SHRM-A	
1	Indoor connection capacity (*1)	Total	Standard indoor unit + M-HWM + H-HWM	-	-	90 - 200% (*2) (*3)	-
			Standard indoor unit + M-HWM	65 - 115% (*3)	65 - 115% (*2) (*3)	90 - 135% (*2) (*3)	70 - 135% (*2) (*3)
	Allowed capacity	Standard indoor unit	50 - 115%	50 - 115% (*2)	50 - 120% (*2)	50 - 120% (*2)	
		M-HWM	0 - 50% (*3)	0 - 50% (*3)	0 - 67.5% (*3)	0 - 67.5% (*3)	
		H-HWM	-	-	0 - 100% (*3)	-	
M-HWM + H-HWM	-	-	0 - 100% (*3)	-			
2	Maximum indoor unit quantity	Total	Standard indoor unit + M-HWM + H-HWM	-	-	32	-
			Standard indoor unit + M-HWM	64	128	32	54
	Allowed number	Standard indoor unit	2 - 64	2 - 128	2 - 32	2 - 54	
		M-HWM	0 - 2	0 - 14	0 - 14	0 - 6	
		H-HWM	-	-	0 - 12	-	
M-HWM + H-HWM	-	-	0 - 14	-			
3	Height difference between outdoor and indoor units H1 (*4) (Including HWM)	H2, H4, H5 > 3 m	Upper outdoor units	50 m	50 m	50 m	50 m
			Lower outdoor units	30 m	30 m	30 m	40 m
		H2, H4, H5 ≤ 3 m	Upper outdoor units	70 m	70 m	70 m	70 m
			Lower outdoor units	40 m	40 m	30 m	40 m
	Height difference between indoor units (Including HWM) H2, H4, H5 (*4)	Indoor - Indoor H2	Upper outdoor units	3 m (*5)	40 m (*2)	40 m (*2)	40 m (*2)
			Lower outdoor units	10 m (*5)	40 m (*2)	15 m (*6)	15 m / 30 m (*7)
		HWM - HWM H4	Upper outdoor units	3 m	40 m (*2)	40 m (*2)	40 m (*2)
			Lower outdoor units	3 m	40 m (*2)	15 m (*6)	15 m / 30 m (*7)
		Indoor - HWM H5	Upper outdoor units	3 m (*5)	40 m (*2)	40 m (*2)	40 m (*2)
			Lower outdoor units	10 m (*5)	40 m (*2)	15 m (*6)	15 m / 30 m (*7)
Height between outdoor units H3			5 m	5 m	5 m	-	
Height difference between indoor units in group control by one Flow Selector unit H6			-	-	0.5 m	15 m	

(*1): Ratio of connected total indoor unit capability to outdoor unit capability.

(*2): Maximum indoor connection capacity is varied depending on the height difference between indoor unit H2, H4, H5.

Combination of indoor units		SMMS-u	SHRM-e and SHRM-A
Standard indoor unit + M-HWM + H-HWM	H2, H4, H5 ≤ 15 m	-	Max. 200% (Standard indoor unit < 120%)
	H2, H4, H5 > 15 m	-	Max. 125% (Standard indoor unit < 100%)
Standard indoor unit + M-HWM	H2, H4, H5 ≤ 15 m	Max. 115% (Standard indoor unit < 115%)	Max. 135% (Standard indoor unit < 120%)
	H2, H4, H5 > 15 m	Max. 105% (Standard indoor unit < 105%)	Max. 125% (Standard indoor unit < 100%)

(*3): HWM connecting capacity should be smaller than standard indoor unit.

(*4): As for 44 HP to 54 HP of SHRM-e, contact our agent.

(*5): When M-HWM and standard indoor units are not operated simultaneously, it is possible up to 40 m.

(*6): When system capacity is greater than 28 HP, height difference between indoor units is limited to 3 m. If the height difference between indoor units exceeds 3 m with a capacity greater than 28 HP there may be a case of capacity shortage in cooling.

(*7): If H2, H4 and H5 exceed 15 m, it is prohibited to reduce the diameter of the liquid pipe.

NOTE

Design the system that total capacity of simultaneous heating operation is 100% or less. If total capacity of simultaneous heating is over 100%, then each indoor units or HWM performance is descended.

▼ Figure 1

M-HWM: Mid temperature Hot water module

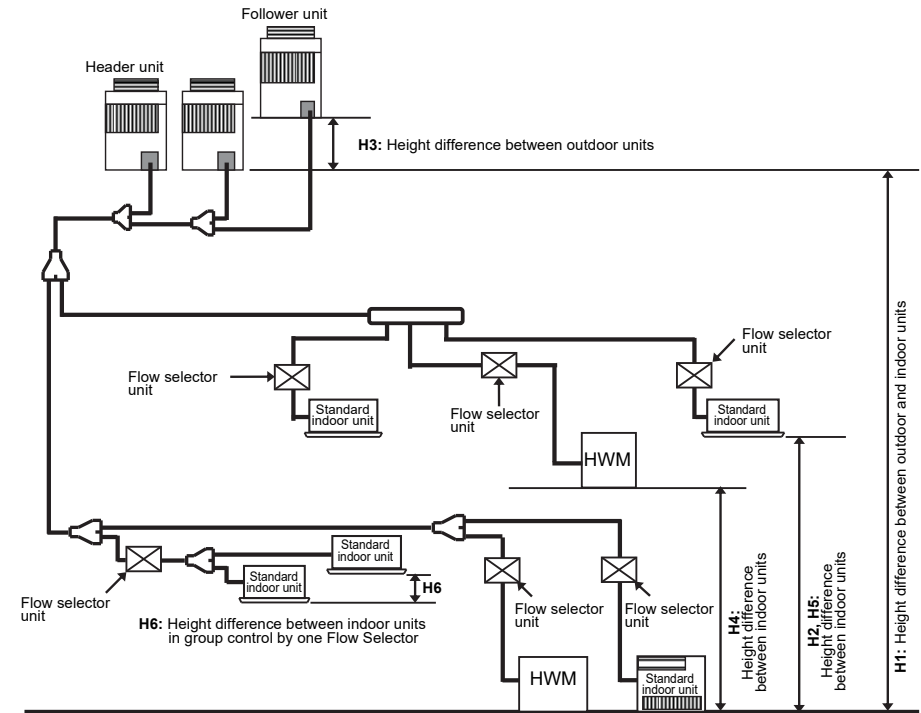

H1: Height difference between outdoor units and indoor units (Including HWM)

H2: Height difference between standard indoor units

H3: Height difference between outdoor units

H4: Height difference between HWMs

H5: Height difference between standard indoor units and HWMs

NOTE

It is prohibited to connect the standard indoor unit and the HWM to the same Flow Selector unit in SHRM-e and SHRM-A system.

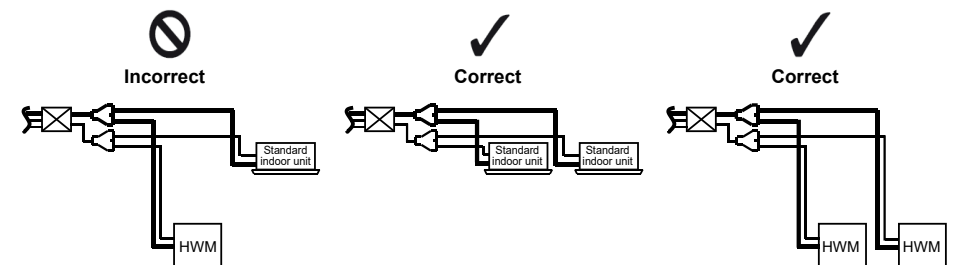

In the case of SMMS-e system including the Hot water module

M-HWM: Mid temperature Hot water module

SMMS-e		Capacity code of outdoor unit (HP)	Maximum indoor unit quantity	Total capacity code of indoor units (HP) Standard indoor unit + M-HWM Total capacity 65 - 115%	
Standard model	MMY-MAP0806HT8P	8	18	5.2 to 9.2	
	MMY-MAP1006HT8P	10	22	6.5 to 11.5	
	MMY-MAP1206HT8P	12	27	7.8 to 13.8	
	MMY-MAP1406HT8P	14	31	9.1 to 16.1	
	MMY-MAP1606HT8P	16	36	10.4 to 18.4	
	MMY-MAP1806HT8P	18	40	11.7 to 20.7	
	MMY-MAP2006HT8P	20	45	13.0 to 23.0	
	MMY-MAP2206HT8P	22	49	14.3 to 25.3	
	MMY-AP2416HT8P	24	54	15.6 to 27.6	
	MMY-AP2616HT8P	26	58	16.9 to 29.9	
	MMY-AP2816HT8P	28	63	18.2 to 32.2	
	MMY-AP3016HT8P	30	64	19.5 to 34.5	
	MMY-AP3216HT8P	32	64	20.8 to 36.8	
	MMY-AP3416HT8P	34	64	22.1 to 39.1	
	MMY-AP3616HT8P	36	64	23.4 to 41.4	
	MMY-AP3816HT8P	38	64	24.7 to 43.7	
	MMY-AP4016HT8P	40	64	26.0 to 46.0	
	MMY-AP4216HT8P	42	64	27.3 to 48.3	
	MMY-AP4416HT8P	44	64	28.6 to 50.6	
	MMY-AP4616HT8P	46	64	29.9 to 52.9	
	MMY-AP4816HT8P	48	64	31.2 to 55.2	
	MMY-AP5016HT8P	50	64	32.5 to 57.5	
	MMY-AP5216HT8P	52	64	33.8 to 59.8	
	MMY-AP5416HT8P	54	64	35.1 to 62.1	
	MMY-AP5616HT8P	56	64	36.4 to 64.4	
	MMY-AP5816HT8P	58	64	37.7 to 66.7	
	MMY-AP6016HT8P	60	64	39.0 to 69.0	
	High efficiency / Heating capacity priority model	MMY-AP2026HT8P	20	45	13.0 to 23.0
		MMY-AP2226HT8P	22	49	14.3 to 25.3
		MMY-AP3626HT8P	36	64	23.4 to 41.4
MMY-AP3826HT8P		38	64	24.7 to 43.7	
MMY-AP4026HT8P		40	64	26.0 to 46.0	
MMY-AP4226HT8P		42	64	27.3 to 48.3	
MMY-AP4426HT8P		44	64	28.6 to 50.6	
MMY-AP5426HT8P	54	64	35.1 to 62.1		

H2, H4, H5: Height difference between indoor unit (Including HWM)

▼ Capacity code of Mid temperature Hot water module

The capacity code of the Hot water module is different from the capacity code of the standard indoor unit.

Mid temperature Hot water module		MMW-UP0271LQ-E	MMW-UP0561LQ-E
Capacity rank type		027	056
Capacity code	Equivalent to HP (HP)	2.5	5
Equivalent to capacity (kW)		7.1	14.0

▼ Capacity code of standard indoor unit

Capacity rank type		005	007	009	012	015	018	024	027
Capacity code	Equivalent to HP (HP)	0.6	0.8	1	1.25	1.7	2	2.5	3
Equivalent to capacity (kW)		1.7	2.2	2.8	3.6	4.5	5.6	7.1	8.0

Capacity rank type		030	036	048	056	072	096
Capacity code	Equivalent to HP (HP)	3.2	4	5	6	8	10
Equivalent to capacity (kW)		9.0	11.2	14.0	16.0	22.4	28.0

In the case of SMMS-u system including the Hot water module

M-HWM: Mid temperature Hot water module

SMMS-u		Capacity code of outdoor unit (HP)	Maximum indoor unit quantity	Total capacity code of indoor units (HP) Standard indoor unit + M-HWM	
				H2, H4, H5 ≤ 15 m	H2, H4, H5 > 15 m
				Total capacity 65 - 115% (Standard indoor unit < 115%)	Total capacity 65 - 105% (Standard indoor unit < 105%)
Standard model	MMY-MUP0801HT8P-E	8	18	5.2 to 9.2	5.2 to 8.4
	MMY-MUP1001HT8P-E	10	20	6.5 to 11.5	6.5 to 10.5
	MMY-MUP1201HT8P-E	12	27	7.8 to 13.8	7.8 to 12.6
	MMY-MUP1401HT8P-E	14	31	9.1 to 16.1	9.1 to 14.7
	MMY-MUP1601HT8P-E	16	36	10.4 to 18.4	10.4 to 16.8
	MMY-MUP1801HT8P-E	18	40	11.7 to 20.7	11.7 to 18.9
	MMY-MUP2001HT8P-E	20	45	13.0 to 23.0	13.0 to 21.0
	MMY-MUP2201HT8P-E	22	49	14.3 to 25.3	14.3 to 23.1
	MMY-MUP2401HT8P-E	24	54	15.6 to 27.6	15.6 to 25.2
	MMY-UP2611HT8P-E	26	58	16.9 to 29.9	16.9 to 27.3
	MMY-UP2811HT8P-E	28	63	18.2 to 32.2	18.2 to 29.4
	MMY-UP3011HT8P-E	30	64	19.5 to 34.5	19.5 to 31.5
	MMY-UP3211HT8P-E	32	65	20.8 to 36.8	20.8 to 33.6
	MMY-UP3411HT8P-E	34	66	22.1 to 39.1	22.1 to 35.7
	MMY-UP3611HT8P-E	36	67	23.4 to 41.4	23.4 to 37.8
	MMY-UP3811HT8P-E	38	68	24.7 to 43.7	24.7 to 39.9
	MMY-UP4011HT8P-E	40	69	26.0 to 46.0	26.0 to 42.0
	MMY-UP4211HT8P-E	42	70	27.3 to 48.3	27.3 to 44.1
	MMY-UP4411HT8P-E	44	71	28.6 to 50.6	28.6 to 46.2
	MMY-UP4611HT8P-E	46	72	29.9 to 52.9	29.9 to 48.3
	MMY-UP4811HT8P-E	48	73	31.2 to 55.2	31.2 to 50.4
	MMY-UP5011HT8P-E	50	74	32.5 to 57.5	32.5 to 52.5
	MMY-UP5211HT8P-E	52	75	33.8 to 59.8	33.8 to 54.6
	MMY-UP5411HT8P-E	54	76	35.1 to 62.1	35.1 to 56.7
	MMY-UP5611HT8P-E	56	77	36.4 to 64.4	36.4 to 58.8
	MMY-UP5811HT8P-E	58	78	37.7 to 66.7	37.7 to 60.9
	MMY-UP6011HT8P-E	60	79	39.0 to 69.0	39.0 to 63.0
	MMY-UP6211HT8P-E	62	80	40.3 to 71.3	40.3 to 65.1
	MMY-UP6411HT8P-E	64	81	41.6 to 73.6	41.6 to 67.2
	MMY-UP6611HT8P-E	66	82	42.9 to 75.9	42.9 to 69.3
MMY-UP6811HT8P-E	68	83	44.2 to 78.2	44.2 to 71.4	
MMY-UP7011HT8P-E	70	84	45.5 to 80.5	45.5 to 73.5	
MMY-UP7211HT8P-E	72	85	46.8 to 82.8	46.8 to 75.6	
MMY-UP7411HT8P-E	74	86	48.1 to 85.1	48.1 to 77.7	
MMY-UP7611HT8P-E	76	87	49.4 to 87.4	49.4 to 79.8	

H2, H4, H5: Height difference between indoor unit (Including HWM)

SMMS-u		Capacity code of outdoor unit (HP)	Maximum indoor unit quantity	Total capacity code of indoor units (HP) Standard indoor unit + M-HWM	
				H2, H4, H5 ≤ 15 m	H2, H4, H5 > 15 m
				Total capacity 65 - 115% (Standard indoor unit < 115%)	Total capacity 65 - 105% (Standard indoor unit < 105%)
Standard model	MMY-UP7811HT8P-E	78	88	50.7 to 89.7	50.7 to 81.9
	MMY-UP8011HT8P-E	80	90	52.0 to 92.0	52.0 to 84.0
	MMY-UP8211HT8P-E	82	92	53.3 to 94.3	53.3 to 86.1
	MMY-UP8411HT8P-E	84	94	54.6 to 96.6	54.6 to 88.2
	MMY-UP8611HT8P-E	86	96	55.9 to 98.9	55.9 to 90.3
	MMY-UP8811HT8P-E	88	98	57.2 to 101.2	57.2 to 92.4
	MMY-UP9011HT8P-E	90	100	58.5 to 103.5	58.5 to 94.5
	MMY-UP9211HT8P-E	92	102	59.8 to 105.8	59.8 to 96.6
	MMY-UP9411HT8P-E	94	104	61.1 to 108.1	61.1 to 98.7
	MMY-UP9611HT8P-E	96	106	62.4 to 110.4	62.4 to 100.8
	MMY-UP9811HT8P-E	98	108	63.7 to 112.7	63.7 to 102.9
	MMY-UP10011HT8P-E	100	110	65.0 to 115.0	65.0 to 105.0
	MMY-UP10211HT8P-E	102	112	66.3 to 117.3	66.3 to 107.1
	MMY-UP10411HT8P-E	104	114	67.6 to 119.6	67.6 to 109.2
	MMY-UP10611HT8P-E	106	116	68.9 to 121.9	68.9 to 111.3
	MMY-UP10811HT8P-E	108	118	70.2 to 124.2	70.2 to 113.4
	MMY-UP11011HT8P-E	110	120	71.5 to 126.5	71.5 to 115.5
	MMY-UP11211HT8P-E	112	122	72.8 to 128.8	72.8 to 117.6
	MMY-UP11411HT8P-E	114	124	74.1 to 131.1	74.1 to 119.7
	MMY-UP11611HT8P-E	116	126	75.4 to 133.4	75.4 to 121.8
MMY-UP11811HT8P-E	118	128	76.7 to 135.7	76.7 to 123.9	
MMY-UP12011HT8P-E	120	128	78.0 to 138.0	78.0 to 126.0	

H2, H4, H5: Height difference between indoor unit (Including HWM)

▼ Capacity code of Mid temperature Hot water module

The capacity code of the Hot water module is different from the capacity code of the standard indoor unit.

Mid temperature Hot water module		MMW-UP0271LQ-E	MMW-UP0561LQ-E
Capacity rank type		027	056
Capacity code	Equivalent to HP (HP)	2.5	5
Equivalent to capacity		(kW) 7.1	14.0

▼ Capacity code of standard indoor unit

Capacity rank type	005	007	009	012	015	018	024	027
Capacity code	0.6	0.8	1	1.25	1.7	2	2.5	3
Equivalent to capacity	(kW) 1.7	2.2	2.8	3.6	4.5	5.6	7.1	8.0

Capacity rank type	030	036	048	056	072	096
Capacity code	3.2	4	5	6	8	10
Equivalent to capacity	(kW) 9.0	11.2	14.0	16.0	22.4	28.0

In the case of SHRM-e system including the Hot water module

M-HWM: Mid temperature Hot water module

H-HWM: High temperature Hot water module

SHRM-e	Capacity code of outdoor unit (HP)	Maximum indoor unit quantity	Total capacity code of indoor units (HP) Standard indoor unit + M-HWM + H-HWM		Total capacity code of indoor units (HP) Standard indoor unit + M-HWM	
			H2, H4, H5 ≤ 15 m	H2, H4, H5 > 15 m	H2, H4, H5 ≤ 15 m	H2, H4, H5 > 15 m
			Total capacity 90 - 200% (Standard indoor unit < 120%)	Total capacity 90 - 125% (Standard indoor unit < 100%)	Total capacity 90 - 135% (Standard indoor unit < 120%)	Total capacity 90 - 125% (Standard indoor unit < 100%)
MMY-MAP0806FT8P	8	18	7.2 to 16.0	7.2 to 10.0	7.2 to 10.8	7.2 to 10.0
MMY-MAP1006FT8P	10	22	9.0 to 20.0	9.0 to 12.5	9.0 to 13.5	9.0 to 12.5
MMY-MAP1206FT8P	12	27	10.8 to 24.0	10.8 to 15.0	10.8 to 16.2	10.8 to 15.0
MMY-MAP1406FT8P	14	31	12.6 to 28.0	12.6 to 17.5	12.6 to 18.9	12.6 to 17.5
MMY-MAP1606FT8P	16	32	14.4 to 32.0	14.4 to 20.0	14.4 to 21.6	14.4 to 20.0
MMY-MAP1806FT8P	18	32	16.2 to 36.0	16.2 to 22.5	16.2 to 24.3	16.2 to 22.5
MMY-MAP2006FT8P	20	32	18.0 to 37.0 (*1)	18.0 to 25.0	18.0 to 25.0 (*2)	18.0 to 25.0
MMY-MAP2206FT8P	22	32	19.8 to 44.0	19.8 to 27.5	19.8 to 29.7	19.8 to 27.5
MMY-AP2416FT8P	24	32	21.6 to 48.0	21.6 to 30.0	21.6 to 32.4	21.6 to 30.0
MMY-AP2616FT8P	26	32	23.4 to 52.0	23.4 to 32.5	23.4 to 35.1	23.4 to 32.5
MMY-AP2816FT8P	28	32	25.2 to 56.0	25.2 to 35.0	25.2 to 37.8	25.2 to 35.0
MMY-AP3016FT8P	30	32	27.0 to 60.0	27.0 to 37.5	27.0 to 40.5	27.0 to 37.5
MMY-AP3216FT8P	32	32	28.8 to 64.0	28.8 to 40.0	28.8 to 43.2	28.8 to 40.0
MMY-AP3416FT8P	34	32	30.6 to 68.0	30.6 to 42.5	30.6 to 45.9	30.6 to 42.5
MMY-AP3616FT8P	36	32	32.4 to 72.0	32.4 to 45.0	32.4 to 48.6	32.4 to 45.0
MMY-AP3816FT8P	38	32	34.2 to 72.0 (*1)	34.2 to 47.5	34.2 to 49.4 (*2)	34.2 to 47.5
MMY-AP4016FT8P	40	32	36.0 to 74.0 (*1)	36.0 to 50.0	36.0 to 50.0 (*2)	36.0 to 50.0
MMY-AP4216FT8P	42	32	37.8 to 84.0	37.8 to 52.5	37.8 to 56.7	37.8 to 52.5
MMY-AP4416FT8P	44	32	39.6 to 88.0	39.6 to 55.0	39.6 to 59.4	39.6 to 55.0
MMY-AP4616FT8P	46	32	41.4 to 92.0	41.4 to 57.5	41.4 to 62.1	41.4 to 57.5
MMY-AP4816FT8P	48	32	43.2 to 96.0	43.2 to 60.0	43.2 to 64.8	43.2 to 60.0
MMY-AP5016FT8P	50	32	45.0 to 100	45.0 to 62.5	45.0 to 67.5	45.0 to 62.5
MMY-AP5216FT8P	52	32	46.8 to 104	46.8 to 65.0	46.8 to 70.2	46.8 to 65.0
MMY-AP5416FT8P	54	32	48.6 to 108	48.6 to 67.5	48.6 to 72.9	48.6 to 67.5

H2, H4, H5: Height difference between indoor unit (Including HWM)

(*1): 20 HP and 40 HP: 90-185% 38 HP: 90 - 190%

(*2): 20 HP and 40 HP: 90-125% 38 HP: 90 - 130%

▼ Capacity code of Hot water module

The capacity code of the Hot water module is different from the capacity code of the standard indoor unit.

Hot water module			Mid temperature	
			MMW-UP0271LQ-E	MMW-UP0561LQ-E
Capacity rank type			027	056
Capacity code	Equivalent to HP	(HP)	2.5	5
Equivalent to capacity		(kW)	7.1	14.0

▼ Capacity code of standard indoor unit

Capacity rank type		005	007	009	012	015	018	024	027	030	036	048	056	072	096	
Capacity code	Equivalent to HP	(HP)	0.6	0.8	1	1.25	1.7	2	2.5	3	3.2	4	5	6	8	10
Equivalent to capacity		(kW)	1.7	2.2	2.8	3.6	4.5	5.6	7.1	8.0	9.0	11.2	14.0	16.0	22.4	28.0

In the case of SHRM-A system including the Hot water module

M-HWM: Mid temperature Hot water module

SHRM-A	Capacity code of outdoor unit (HP)	Maximum indoor unit quantity	Total capacity code of indoor units (HP) Standard indoor unit + M-HWM	
			H2, H4, H5 ≤ 15 m	H2, H4, H5 > 15 m
			Total capacity 70 - 135% (Standard indoor unit < 120%)	Total capacity 70 - 125% (Standard indoor unit < 100%)
MMY-SUG0801MT8P-E	8	18	5.6 to 10.8	5.6 to 10.0
MMY-SUG1001MT8P-E	10	22	7.0 to 13.5	7.0 to 12.5
MMY-SUG1201MT8P-E	12	27	8.4 to 16.2	8.4 to 15.0
MMY-SUG1401MT8P-E	14	31	9.8 to 18.9	9.8 to 17.5
MMY-SUG1601MT8P-E	16	36	11.2 to 21.6	11.2 to 20.0
MMY-SUG1801MT8P-E	18	40	12.6 to 24.3	12.6 to 22.5
MMY-SUG2001MT8P-E	20	45	14.0 to 27.0	14.0 to 25.0
MMY-SUG2201MT8P-E	22	49	15.4 to 29.7	15.4 to 27.5
MMY-SUG2401MT8P-E	24	54	16.8 to 32.4	16.8 to 30.0

H2, H4, H5: Height difference between indoor unit (Including HWM)

▼ Capacity code of Hot water module

The capacity code of the Hot water module is different from the capacity code of the standard indoor unit.

Hot water module		Mid temperature	
		MMW-UP0271LQ-E	MMW-UP0561LQ-E
Capacity rank type		027	056
Capacity code	Equivalent to HP (HP)	2.5	5
Equivalent to capacity	(kW)	7.1	14.0

▼ Capacity code of standard indoor unit

Capacity rank type		005	007	009	012	015	018	024	027	030	036	048	056	072	096
Capacity code	Equivalent to HP (HP)	0.6	0.8	1	1.25	1.7	2	2.5	3	3.2	4	5	6	8	10
Equivalent to capacity	(kW)	1.7	2.2	2.8	3.6	4.5	5.6	7.1	8.0	9.0	11.2	14.0	16.0	22.4	28.0

■ Example of Installation for Hot Water Module water piping

GENERAL NOTE

- To install the hot water module, connect the pump and line heater, (procured locally).
- Do not connect more than one hot water module to one pump and one line heater, (procured locally).
- Be sure to install one pump and one line heater to one hot water module as shown in the following examples.
- Be sure to attach the air vent valve (procured locally) vertically at the highest possible place where air tends to rise.

HWM: Hot Water Module

Sample 1.

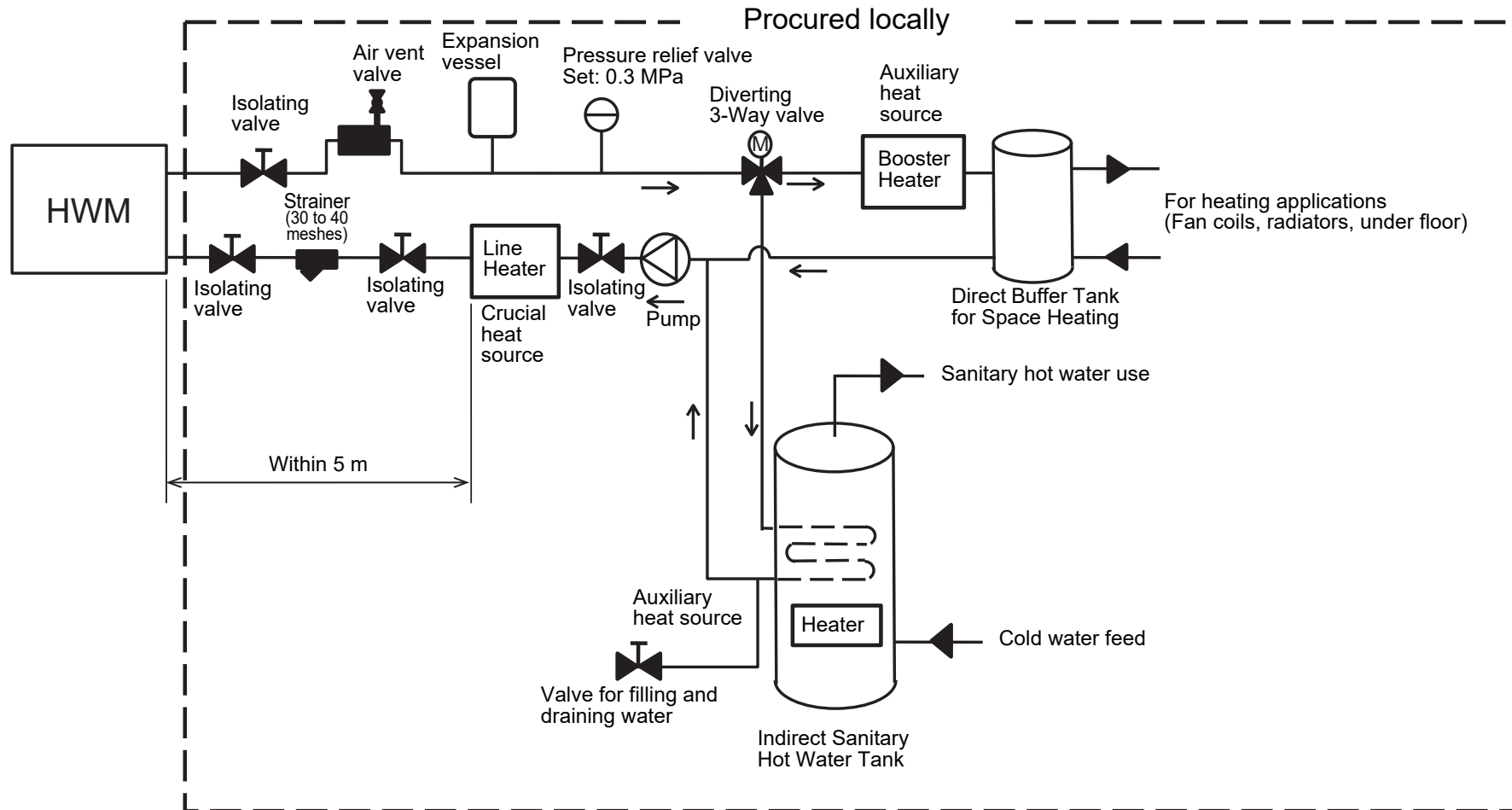

Sample 2.

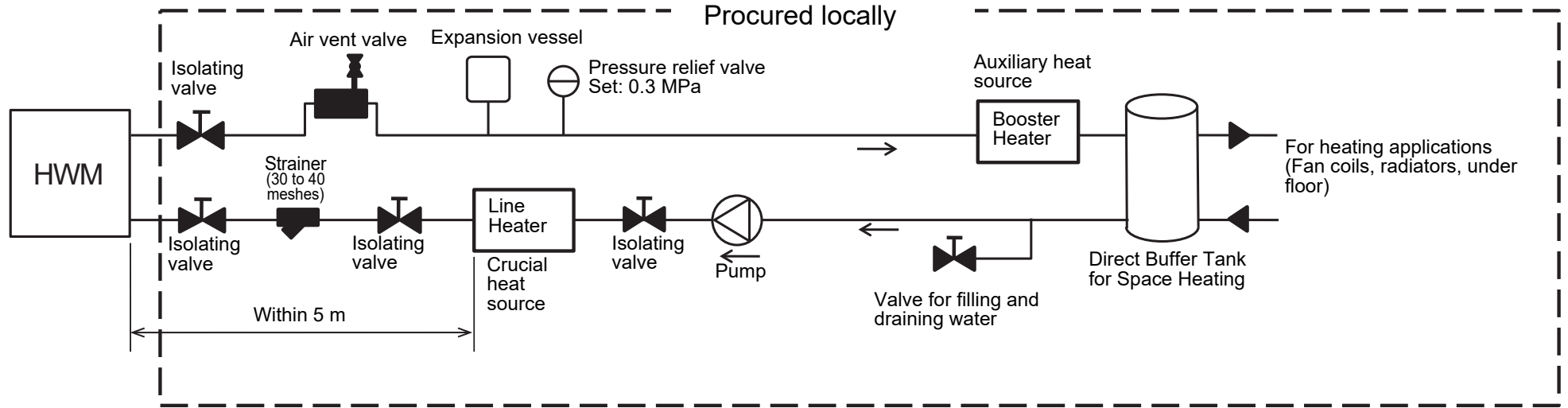

Sample 3.

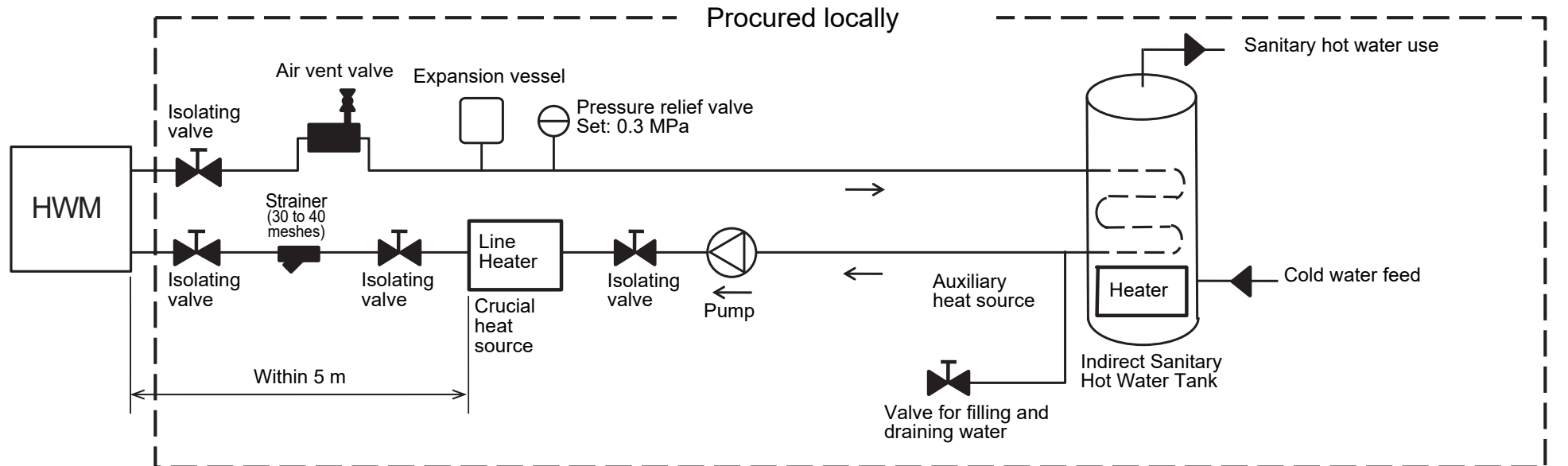

3.2 System able to be combined for MiNi-SMMS-e series (MCY-***)

The Mid temperature Hot Water Module is connectable to MiNi-SMMS-e.

M-HWM: Mid temperature Hot Water Module

No.	Item			M-HWM connection		Without M-HWM connection
1	System capacity			Depending on the outdoor unit to be connected		
2	Indoor connection capacity		Max.	130% (*1) (Excluding M-HWM) 200% (Including M-HWM)	130% (*1)	
			Min.	80% (*1) (Excluding M-HWM)	80% (*1)	
3	M-HWM connection capacity per refrigerant system			Max.	100% or less	-
4	Height difference	Height between outdoor and indoor units (including M-HWM) H1	Upper outdoor units	(*2)	See Figure 1	(*2)
			Lower outdoor units	(*2)		(*2)
		Indoor - Indoor H2	Upper outdoor units	10 m		(*3)
			Lower outdoor units	10 m		-
		Indoor - M-HWM H4	Upper outdoor units	10 m		-
			Lower outdoor units	10 m		-
		M-HWM - M-HWM H3	Upper outdoor units	10 m		-
			Lower outdoor units	10 m		-

(*1): For more information, please read the Installation Manual provided with the outdoor unit. (Total capacity code of connectable indoor units)

(*2): For more information, please read the Installation Manual provided with the outdoor unit. (Where H1 is indicated)

(*3): Please read the Installation Manual provided with the outdoor unit. (Where H2 is indicated)

▼ Capacity code of outdoor unit, Maximum indoor unit quantity and total capacity code of indoor unit

MiNi-SMMS-e	Capacity code of outdoor unit (HP)	Maximum indoor unit quantity	Total capacity code of indoor units (HP) Standard indoor unit + M-HWM Total capacity 80 - 200%
MCY-MHP0806HS8*	8	12	6.4 to 16.0
MCY-MHP1006HS8*	10	16	8.0 to 20.0

▼ Capacity code of Mid temperature Hot water module

The capacity code of the Hot water module is different from the capacity code of the standard indoor unit.

Mid temperature Hot water module		MMW-UP0271LQ-E	MMW-UP0561LQ-E
Capacity rank type		027	056
Capacity code	Equivalent to HP (HP)	2.5	5
Equivalent to capacity (kW)		7.1	14.0

▼ Capacity code of standard indoor unit

Capacity rank type	005	007	009	012	015	018	024	027
Capacity code	0.6	0.8	1	1.25	1.7	2	2.5	3
Equivalent to capacity (kW)		1.7	2.2	2.8	3.6	4.5	5.6	7.1

Capacity rank type	030	036	048	056
Capacity code	3.2	4	5	6
Equivalent to capacity (kW)		9.0	11.2	14.0

▼ Figure 1
 <Upper outdoor units>

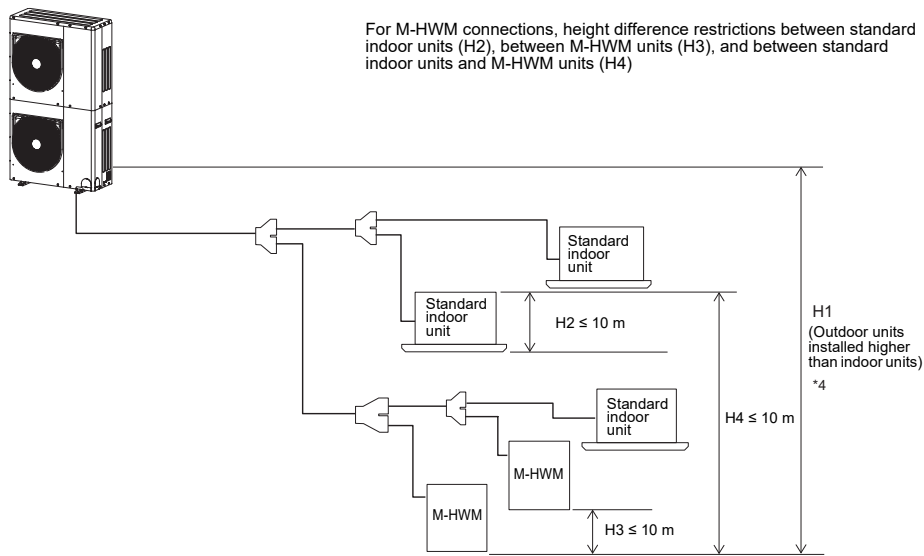

*4. Please read the Installation Manual provided with the outdoor unit. (Where H1 is indicated)
 H1: Height difference between outdoor units and indoor units (including M-HWM)
 H2: Height difference between standard indoor units
 H3: Height difference between M-HWMs
 H4: Height difference between standard indoor units and M-HWMs

<Lower outdoor units > M-HWM: Mid temperature Hot Water Module

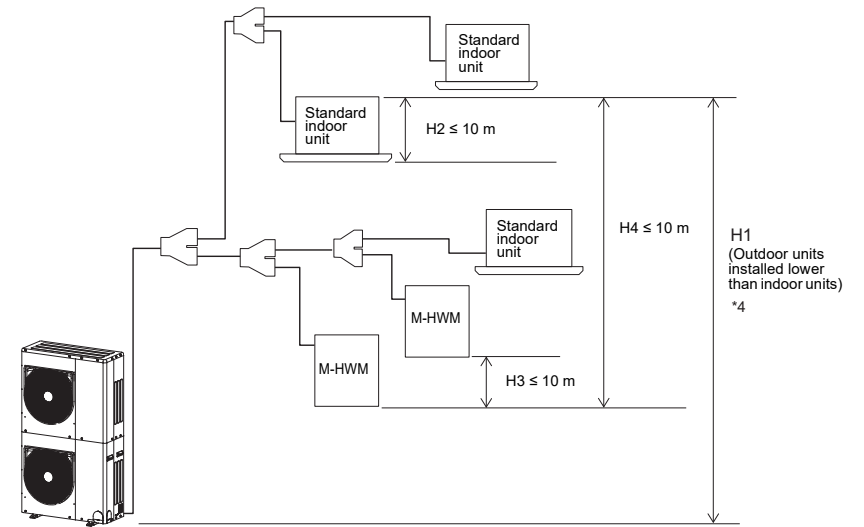

*4. Please read the Installation Manual provided with the outdoor unit. (Where H1 is indicated)
 H1: Height difference between outdoor units and indoor units (including M-HWM)
 H2: Height difference between standard indoor units
 H3: Height difference between M-HWMs
 H4: Height difference between standard indoor units and M-HWMs

■ Example of Installation for Hot Water Module water piping for MiNi-SMMS-e series (MCY-***)

GENERAL NOTE

- To install the hot water module, connect the pump and line heater, (procured locally).
- Do not connect more than one hot water module to one pump and one line heater, (procured locally).
- Be sure to install one pump and one line heater to one hot water module as shown in the following examples.
- Be sure to attach the air vent valve (procured locally) vertically at the highest possible place where air tends to rise.

HWM: Hot Water Module

Sample 1.

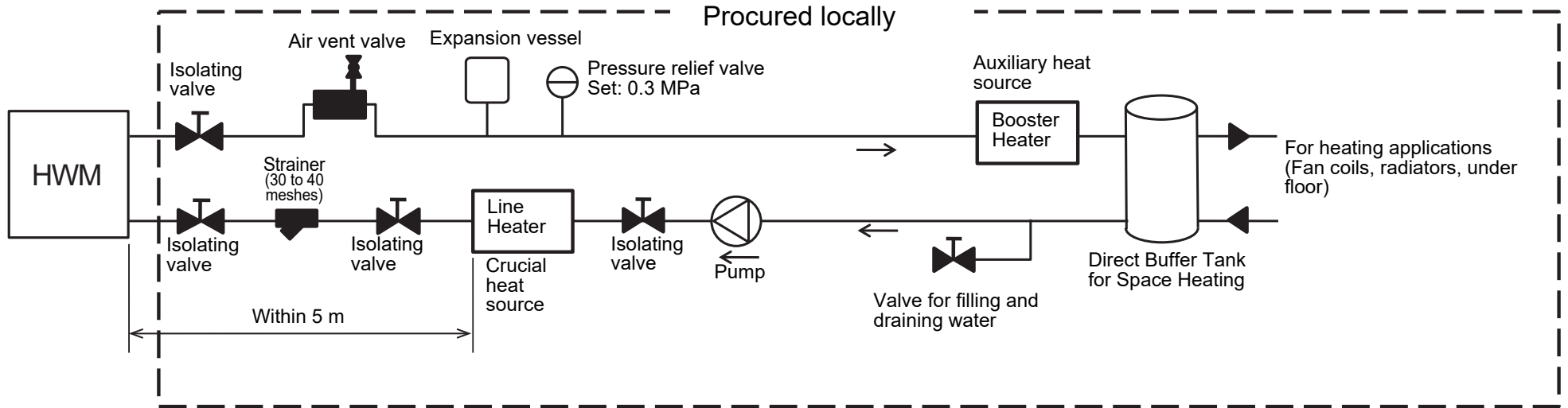

4 Selection of installation place

Avoid installing in the following places

Select a location for the indoor unit where the cool or warm air will circulate evenly.

Avoid installation in the following kinds of locations.

- Saline area (coastal area)
- Locations with acidic or alkaline atmospheres (such as areas with hot springs, factories where chemicals or pharmaceuticals are made and places where the exhaust air from combustion appliances will be sucked into the unit).
Doing so may cause the heat exchanger and other parts to become corroded.
- Locations with atmospheres with mist of cutting oil or other types of machine oil.
Doing so may cause the heat exchanger to become corroded, mists caused by the blockage of the heat exchanger to be generated, the plastic parts to be damaged, the heat insulators to peel off, and other such problems to result.
- Locations where vapors from food oils are formed (such as kitchens where food oils are used).
The plastic parts to be damaged, and other such problems to result.
- Locations where an in-house power generator is used for the power supply.
The power line frequency and voltage may fluctuate, and the hot water module may not work properly as a result.
- On truck cranes, ships or other moving conveyances.
- The hot water module must not be used for special applications (such as for storing food, plants, precision instruments or art works).
(The quality of the items stored may be degraded.)
- Locations where high frequencies are generated (by inverter equipment, in-house power generators, medical equipment or communication equipment).
(Malfunctioning or control trouble in the hot water module or noise may adversely affect the equipment's operation.)
- Locations where there is anything under the unit installed that would be compromised by wetness.
(If the drain has become blocked or when the humidity is over 85%, condensation from the hot water module will drip, possibly causing damage to anything underneath.)
- Locations where organic solvents are being used.
- The hot water module cannot be used for liquefied carbonic acid cooling or in chemical plants.
- Location near doors or windows where the hot water module may come into contact with high-temperature, high-humidity outdoor air.
(Condensation may occur as a result.)
- Locations where special sprays are used frequently.
- Places where iron or other metal dust is present. If iron or other metal dust adheres to or collects on the interior of the hot water module, it may spontaneously combust and start a fire.
- Locations such as living rooms and bedrooms where you can easily be bothered by noise. Noise may become a problem.

CAUTION

- Do not install hot water module in a place where water freezes.
 - Do not install the hot water module in a place where combustible gas may leak.
 - Do not install the hot water module in a place exposed to rain or water.
 - Do not install the hot water module near equipment which generates heat.
 - Do not install the hot water module to a movable object.
 - Do not install the hot water module in a place exposed to vibration.
 - The hot water module must be installed in accordance with national wiring regulation.
 - The hot water module must not be installed in a high humidity condition area.
 - The hot water module must not be installed in a high dusty area.
 - When an outdoor unit using R32 refrigerant is combined with hot water module, be attention to the floor area in the room to be installed. Hot water module cannot be installed in rooms with a floor area less than the minimum floor area. For details, follow the Installation Manual of the R32 refrigerant outdoor unit.
-

■ Installation atmosphere

Installation atmosphere of the unit is as follows. Be careful of installation atmosphere. It becomes a cause of failure of a product by dewing or freezing.

Installation atmosphere	Dry-bulb temp. (°C)	5 to 32
	Wet-bulb temp. (°C)	24 (Max.)
	RH (%)	30 to 85
	Allowable dew point (°C Wet-bulb temp)	23 or less

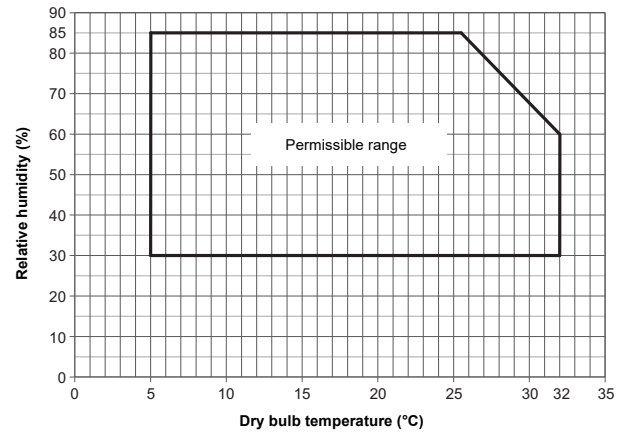

■ Installation space

(Unit: mm)

Reserve sufficient space required for installation or service work.

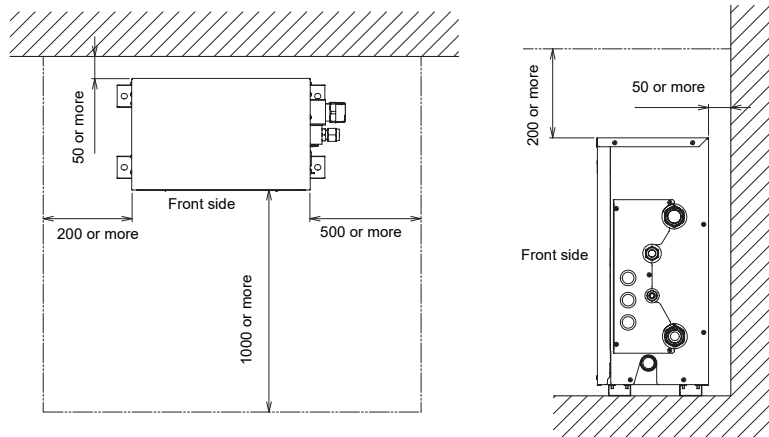

5 Installation

⚠ CAUTION

- Strictly comply with the following rules to prevent damage of the hot water modules and human injury.
- Do not put a heavy article on the hot water module or let a person get on it. (Even units are packaged)
- Carry in the hot water module as it is packaged if possible. If carrying in the hot water module unpacked by necessity, use buffering cloth or other material to not damage the unit.
- To move the hot water module, hold the bottom face of the unit only. Do not apply force to the other parts (refrigerant pipe, drain pan, water pipe, foamed parts, resin parts or other parts).
- Carry the package by two or more persons, and do not bundle it with plastic band at positions other than specified.
- To protect yourself from injury, always use PPE (Personal Protective Equipment), that is, wear gloves.
- Install the Hot water module in a place strong enough to withstand the following weights:
Hot water module weight with no water 17.8 kg (027) 20.3 kg (056)
Hot water module weight with full water 18.4 kg (027) 21.6 kg (056)

External dimensions

(Unit: mm)

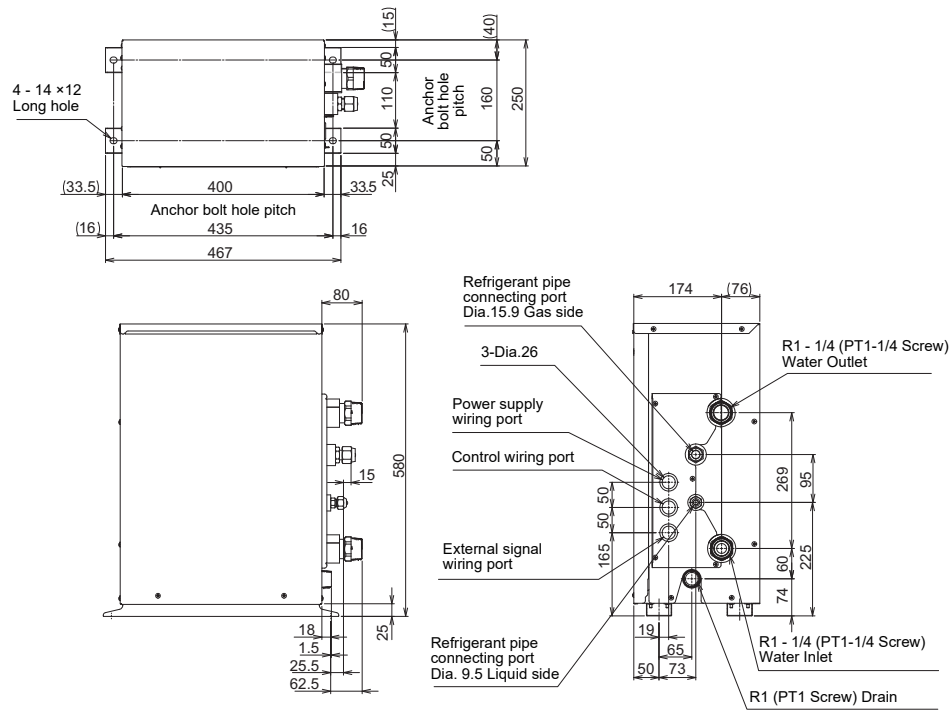

Fixing the hot water module to floor

⚠ WARNING

- **Be sure to install the hot water module in a place able to bear its weight.**
If strength is insufficient, the unit may fall down resulting in human injury.
- **Perform specified installation work to protect earthquakes.**
If the hot water module is imperfectly installed, an accident by falling or dropping may be caused.

⚠ CAUTION

- Drain water is discharged from the hot water module. (Especially while operating)
Install the hot water module in a place with good drainage.
- For installation, be careful of the strength and level of the foundation so that abnormal sounds (vibration or noise) are not generated.
- Be sure to install the hot water module in a place strong enough to withstand its weight. If the base is unstable, reinforce with a concrete base.
- The hot water module must be anchored on a level surface. Use a level to check after installation.
- If the hot water module is installed near a room where noise is a problem, using an anti-vibration stand on the base of the unit is recommended.

1. Fix the hot water module with M8 anchor bolts at 4 positions. 20 mm projection is appropriate for an anchor bolt.

(Unit: mm)

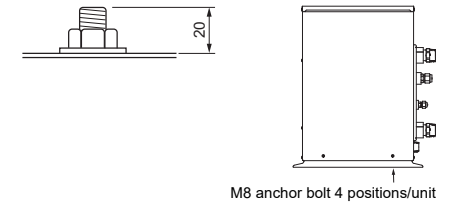

M8 anchor bolt 4 positions/unit

- Anchor bolt positions are as shown below:

(Unit: mm)

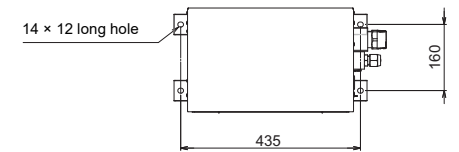

REQUIREMENT

- Fix the unit in a horizontal position.
When unit is fixed to slant, it may cause overflow of drainage.
- Install the unit within the dimension according to the figure below.
- Use level gauge or vinyl hose to confirm whether the unit is fix horizontally.

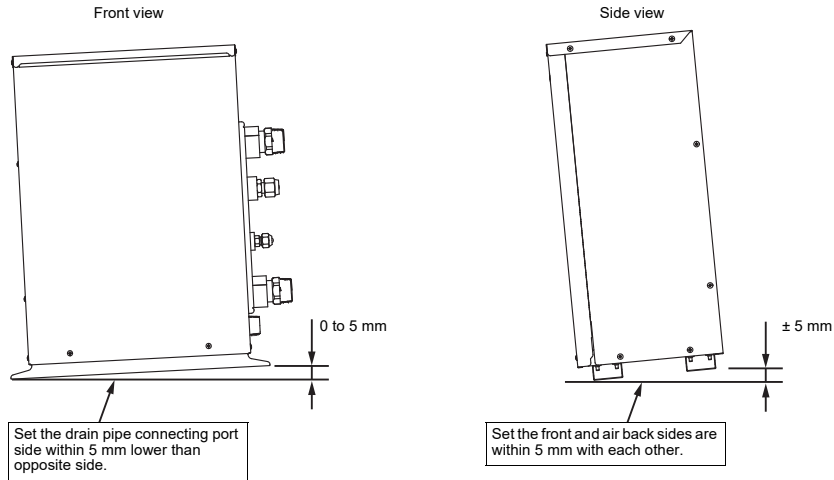

Remove the part for transportation

Be sure to remove the transportation part before operating the unit.

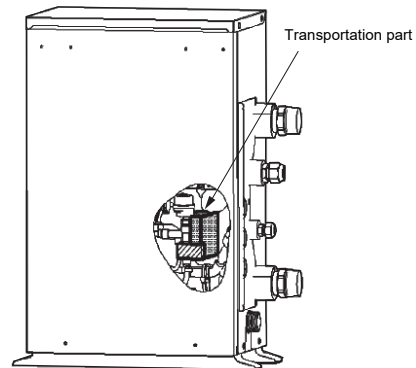

6 Water piping

WARNING

- Install water pipes according to the regulations of respective countries.
- Install water pipes in the freeze-free place.
- Make sure that water pipes have sufficient pressure resistance.
The design pressure is 1.0 MPa.

CAUTION

- Do not use zinc plated water pipes. When steel pipes are used, insulate both ends of the pipes.
- Copper pipes are recommended.
- The water to be used must meet the water quality standard specified in EU directive 98/83 EC.
- **After the vacuuming is completed, carry out the following procedure before adding refrigerant.**
Plate heat exchanger may explode because the water in the plate heat exchanger frozen.
To avoid this phenomenon, ensure that the VRF system is fully commissioned, including the control system, before filling the water circuit.
- The hot water module and the buffer/cylinder tank must be installed on the same floor height.
- The water piping on the inlet side of the hot water module must not be connected with right-angled loop piping (refer to the figure below).
- When flow switch detects a decrease in the water flow rate, the outdoor unit stops.

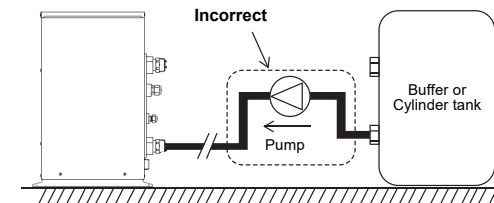
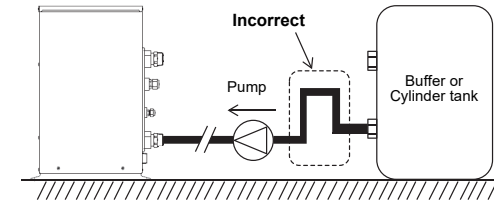

■ Water piping and line heater installation

- Install a suitably sized expansion vessel, 3 bar (0.3 MPa) pressure relief valve, water drain, and fill valve (procured locally).
Follow all local regulations for the installation of closed circuit heating systems.
- Make the piping route a closed circuit. (An open water circuit may cause a failure.)
- Before a long period of none use, purge the water out of the pipes and thoroughly let them dry. Do not add brine to the circulating water.
- Do not use the water used for the unit for drinking or food manufacturing.
- To insure easy maintenance, inspection, and replacement of the unit, use a proper joint, valve, etc (procured locally) on the water inlet and outlet port.
- Be sure to install a strainer with 30 to 40 meshes (procured locally) on the water inlet pipe. If a strainer is not installed, this may cause impaired performance, or damage to the plate heat exchanger from freezing.
- Install a suitable air vent (procured locally) on the water pipe. After sending water through the pipe, be sure to vent the excess air.
- Be sure to attach the air vent valve vertically at the highest possible place where air tends to rise.
- To avoid water leak, wrap some sealing tape around the screw part.
- Water pipes can get very hot, depending on the preset temperature. Wrap the water pipes with heat insulation (procured locally) to prevent burns.
- Be sure to install the line heater (procured locally) on the water inlet side. In addition, position it within 5 m of the water inlet pipe of the hot water module.
- Follow the table below to select a line heater (procured locally) within the range of 40 to 50% of the hot water module's rated capacity.

Hot water module model name	Capacity of line heater (kW)
MMW-UP0271LQ-E	3.2 ~ 4.0
MMW-UP0561LQ-E	6.4 ~ 8.0

■ Pipe size, material and insulator

The following specification for piping work and insulating process are procured locally.

Model	MMW-	UP027	UP056
Connecting pipe (unit side)	Water pipe	Inlet	R1 - 1 / 4
		Outlet	R1 - 1 / 4
Connecting pipes material			Copper pipes are recommended
Insulator			Formed polyethylene foam, thickness: 10 mm or more

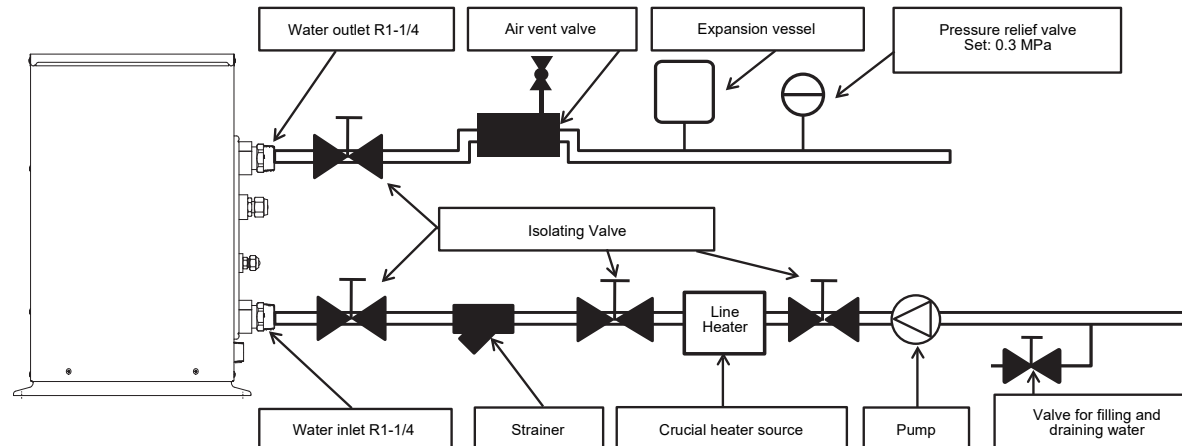

■ Characteristics of hot water module flow rate and pressure loss

The following graph shows the range of flow rates used for the hot water module, and the characteristic pressure losses. Use this as an aid in the local pump procurement process.

027type

	Min.	Rated	Max.
Water flow rate (L/min)	19.5	22.9	26.3
Pressure loss (kPa)	28.5	40.5	53.5

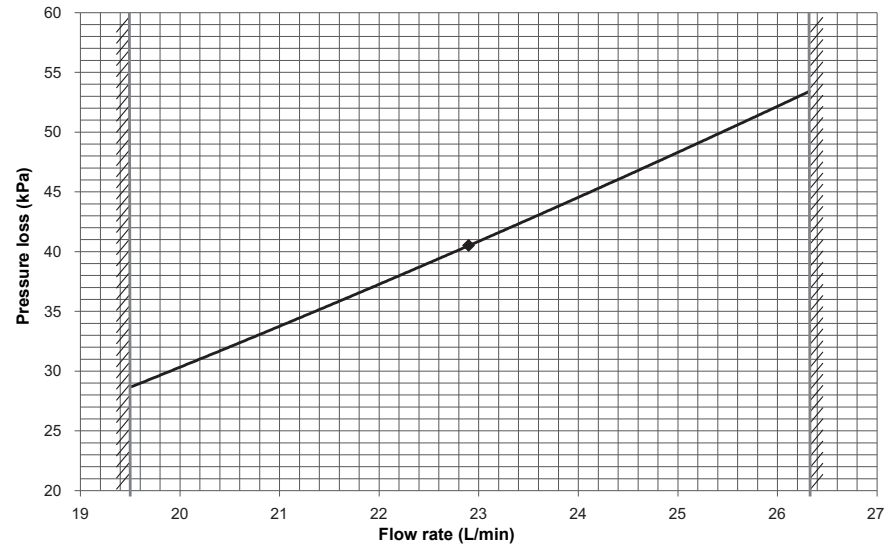

056type

	Min.	Rated	Max.
Water flow rate (L/min)	38.9	45.8	52.6
Pressure loss (kPa)	35.2	44.2	58.2

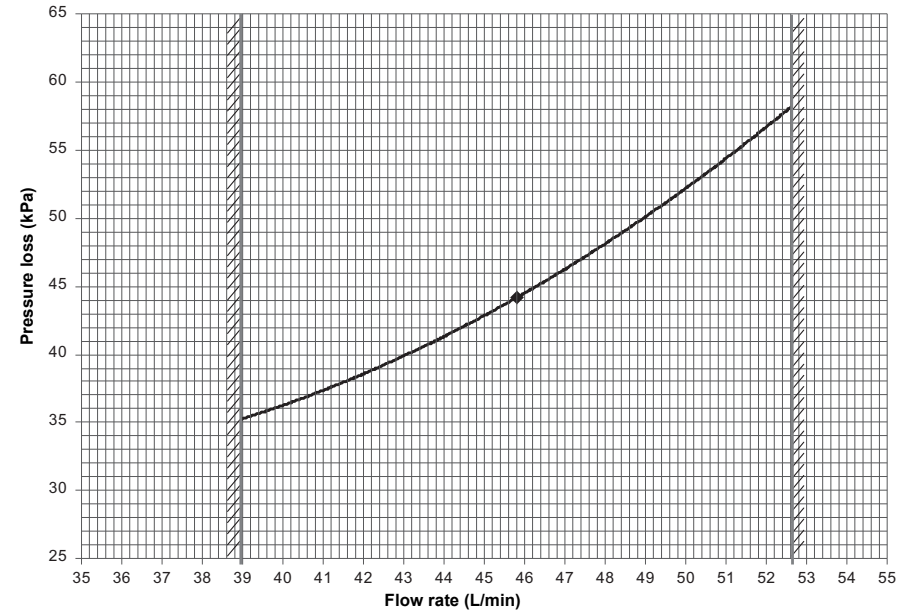

7 Drain piping

⚠ CAUTION

- Following the Installation Manual, perform the drain piping work so that water is properly drained. Apply a heat insulation so as not to cause a dew condensation. Inappropriate piping work may result in water leakage in the room and wet furniture.
- After opening the knockout hole, deburr the edge. Burrs adhered to opening of the knockout hole may causes an injury by touching it.

Drain piping

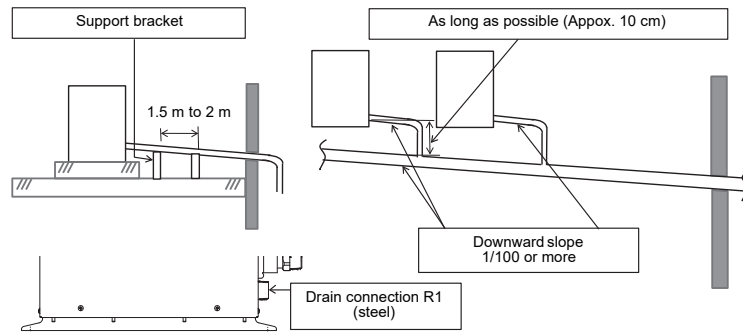

- Provide the indoor drain piping with proper heat insulation.
- Provide the area where the pipe connects to the indoor unit with proper heat insulation. Improper heat insulation will cause condensation to form.
- The drain pipe must be sloping downward (at an angle of 1/100 or more), and do not run the pipe up and down (arched shape) or allow it to form traps. Doing so may cause abnormal sounds.
- Restrict the length of the traversing drain pipe to 20 meters or less. For a long pipe, provide support brackets at intervals of 1.5 to 2 meters to prevent flapping.
- Install the collective piping as shown in the following figure.
- Do not provide any air vents. Otherwise, the drain water will spout, causing water to leak.
- Do not allow any force to be applied to the connection area with the drain pipe.
- To avoid water leak, wrap some sealing tape around the screw part.
- Drain connection is made from steel. Do not connect the joint pipe made from stainless steel.

■ Pipe material, size and insulator

The following materials for piping work and insulating process are procured locally.

Pipe material	Hard vinyl chloride pipe, VP25A (Nominal outer diameter 32 mm)
Insulator	Foamed polyethylene foam, thickness: 10 mm or more

■ Connecting drain pipe

Wrap some sealing tape around the screw part to avoid water leak.

REQUIREMENT

- Connect the hard vinyl chloride pipes certainly so that water does not leak by using adhesive agent for vinyl chloride.
- It takes some time to dry and indurate the adhesive agent. (Refer to the manual of adhesive agent.) Do not apply any extra force on the connecting section until the adhesive agent dried.

■ Check the draining

In the test run, check that water drain is properly performed and water does not leak from the connecting part of the pipes. Check draining also when installed in heating period.

Check the water drainage is surely performed at the test run.
Check also no water leakage is found at the pipe connecting part.

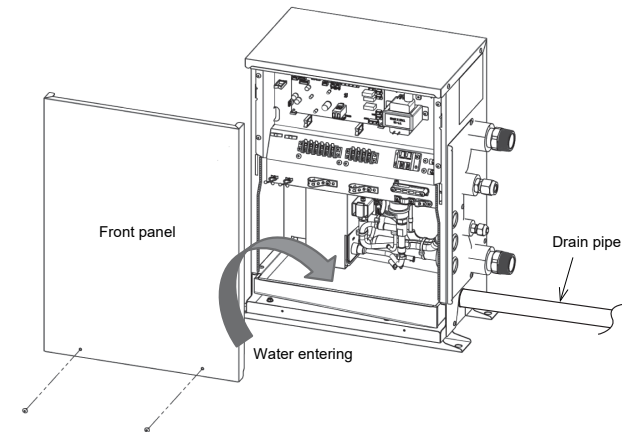

REQUIREMENT

Enter water gradually using a kettle or a hose from drain pan of the discharge port.

⚠ CAUTION

Pour water slowly.
If it is poured urgently, water is spread inside of the indoor unit resulted in a trouble.

Heat insulating process

- After drain check, covering the heat insulator for drain connecting section, wrap the drain pipe with heat insulator (Locally procured) without clearance from the end of the drain pipe connecting port of the hot water module.

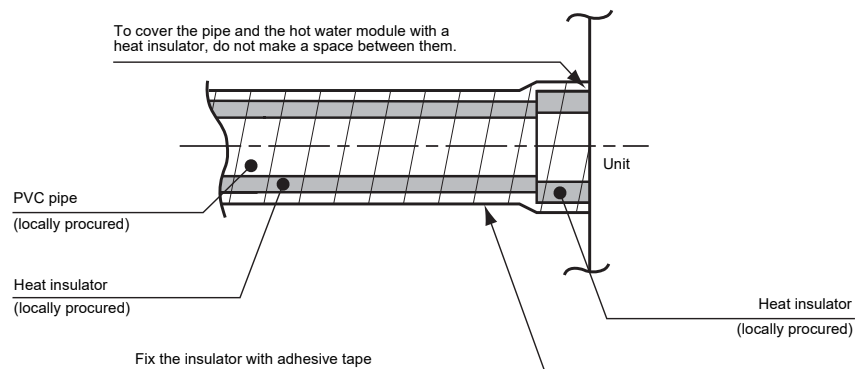

Check the following contents

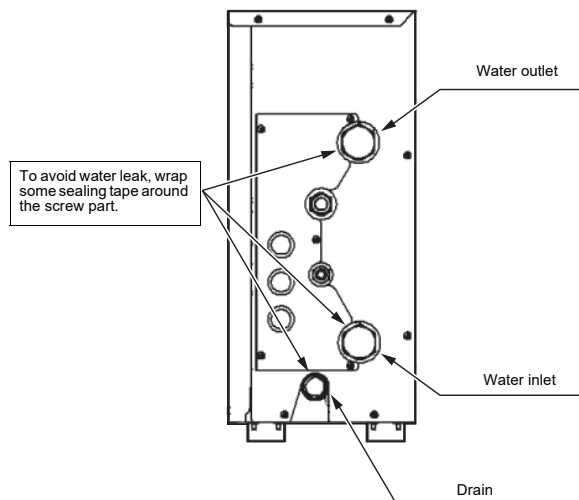

8 Refrigerant piping

CAUTION

When the refrigerant pipe is long, provide support brackets at intervals of 2.5 m to 3 m to clamp the refrigerant pipe. Otherwise, abnormal sound may be generated.
Use the flare nut attached with the indoor unit or R410A flare nut.

Permissible piping length and height difference

They vary depending on the outdoor unit. For details, refer to the Installation Manual attached to the outdoor unit, and this manual (Refer to "3. System control of Hot Water Module").

Pipe size

Model MMW-	Pipe size (mm)	
	Gas side	Liquid side
UP027 to UP056	Dia. 15.9	Dia. 9.5

Connecting refrigerant piping

Flaring

- Cut the pipe with a pipe cutter.**
Remove burrs completely. (Remaining burrs may cause gas leakage.)
- Insert a flare nut into the pipe, and flare the pipe.**
Use the flare nut provided with the unit or the one used for the R410A refrigerant. The flaring dimensions for R410A are different from the ones used for the conventional R22 refrigerant. A new flare tool manufactured for use with the R410A refrigerant is recommended, but the conventional tool can still be used if the projection margin of the copper pipe is adjusted to be as shown in the following table.

Projection margin in flaring: B (Unit: mm)

Outer dia. of copper pipe	R410A tool used	Conventional tool used
6.4, 9.5	0 to 0.5	1.0 to 1.5
12.7, 15.9		

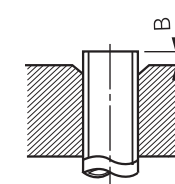

Flaring diameter size: A (Unit: mm)

Outer dia. of copper pipe	A ⁺⁰ / _{-0.4}
6.4	9.1
9.5	13.2
12.7	16.6
15.9	19.7

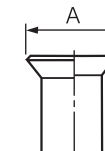

- * In case of flaring for R410A with the conventional flare tool, pull it out approx. 0.5 mm more than that for R22 to adjust to the specified flare size. The copper pipe gauge is useful for adjusting projection margin size.
- The sealed gas was sealed at the atmospheric pressure so when the flare nut is removed, there will no "whooshing" sound: This is normal and is not indicative of trouble.
- Use two wrenches to connect the indoor unit pipe.

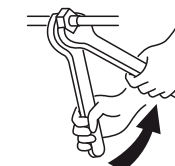

Work using two wrenches

- Use the tightening torque levels as listed in the table below.

Outer dia. of connecting pipe (mm)	Tightening torque (N·m)
6.4	14 to 18
9.5	33 to 42
12.7	50 to 62
15.9	63 to 77

- Tightening torque of flare pipe connections. Pressure of R410A is higher than that of R22. (Approx. 1.6 times) Therefore, using a torque wrench, tighten the flare pipe connecting sections which connect the indoor and outdoor units of the specified tightening torque. Incorrect connections may cause not only a gas leak, but also a trouble of the refrigeration cycle.

⚠ CAUTION

Tightening with an excessive torque may crack the nut depending on installation conditions.

■ Airtight test / air purge, etc.

For air tightness test, adding refrigerant, refer to the Installation Manual attached to the outdoor unit.

⚠ CAUTION

- Do not supply power to the indoor unit and the hot water module until the airtight test and vacuuming are completed. (If the indoor unit or the hot water module is powered on, the pulse motor valve is fully closed, which extends the time for vacuuming.)
- After the vacuuming is completed, carry out the following procedure before adding refrigerant.** Plate heat exchanger may explode because the water in the plate heat exchanger frozen. To avoid this phenomenon, add refrigerant before carrying out a water supply to the water pipe system of the Hot Water Module.

■ Open the valve fully

Open the valve of the outdoor unit fully.

■ Heat insulation process

Apply heat insulation for the pipes separately at liquid side and gas side.

- For the heat insulation to the pipes at gas side, use the material with heat-resisting temperature 120°C or higher.
- To use the attached heat insulation pipe, apply the heat insulation to the pipe connecting section of the hot water module securely without gap.

REQUIREMENT

- Apply the heat insulation to the pipe connecting section of the hot water module securely up to the root without exposure of the pipe. (The pipe exposed to the outside causes water leak.)
- Wrap heat insulator with its slits facing up (ceiling side).

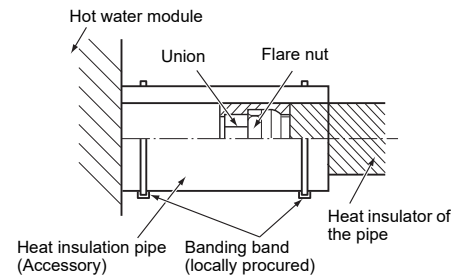

■ Installation of remote controller (Sold separately)

For installation of the wired remote controller, follow the Installation Manual attached with the remote controller.

- Pull out the remote controller cord together with the refrigerant pipe or drain pipe. Pass the remote controller cord through upper side of the refrigerant pipe and drain pipe.
- Do not leave the remote controller at a place exposed to the direct sunlight and near a stove.

9 Electrical connection

⚠ WARNING

- Use the specified wires for wiring connection to the terminals. Securely fix them to prevent external forces applied to the terminals from affecting the terminals.
Incomplete connection or fixation may cause a fire or other trouble.
- Connect earth wire. (grounding work)
Incomplete earthing cause an electric shock.
Do not connect earth wires to gas pipes, water pipes, lightning conductor or telephone earth wires.
- Appliance shall be installed in accordance with national wiring regulations.
Capacity shortage of power circuit or incomplete installation may cause an electric shock or a fire.

⚠ CAUTION

- The wire size and wire length of the communication line differs depending on the outdoor unit series to be connected.
- If incorrect / incomplete wiring is carried out, it will cause an electrical fire or smoke.
- Install an earth leakage breaker that is not tripped by shock waves.
If an earth leakage breaker is not installed, an electric shock may be caused.
- Use the cord clamps attached to the product.
- Do not damage or scratch the conductive core and inner insulator of power and control wires when peeling them.
- Use the power supply wire and control wires of specified thickness, type, and protective devices required.
- Do not connect 220 - 240 V power to the terminal blocks (Uv (U1)), (Uv (U2)), (A), (B) for control wiring. (Otherwise, the system will fail.)
- Perform the electric wiring so that it does not come to contact with the high-temperature part of the pipe.
The coating may melt resulting in an accident.

REQUIREMENT

- For power supply wiring, strictly conform to the Local Regulation in each country.
- For wiring of power supply of the outdoor units, follow the Installation Manual of each outdoor unit.
- After connecting wires to the terminal blocks, provide a trap and fix wires with the cord clamp.
- Run the refrigerant piping line and communication line in the same line.
- Do not turn on the power of the indoor unit until vacuuming of the refrigerant pipes completes.

■ Power supply wire and communication wires specifications

Power supply wire and communication wires are locally procured.

For the power supply specifications, follow to the table below. If capacity is little, it is dangerous because overheat or burnout may be caused.

For specifications of the power capacity of the outdoor unit and the power supply wires, refer to the Installation Manual attached to the outdoor unit.

Indoor unit power supply

- For the power supply of the indoor unit, prepare the exclusive power supply separated from that of the outdoor unit.
- Arrange the power supply, circuit breaker, and main switch of the indoor unit connected to the same outdoor unit so that they are commonly used.
- Power supply wire specification: Cable 3-core 2.5 mm², in conformity with Design 60245 IEC 57.

■ Power supply

Power supply	220 - 240 V ~, 50 Hz	
Power supply switch / circuit breaker or power supply wiring / fuse rating for indoor units should be selected by the accumulated total current values of the indoor units.		
Power supply wiring	Below 50 m	3 × 2.5 mm ² (power supply and earth)

Control wiring, Central controller wiring

- 2-core with non-polarity wires are used for the Control wiring between indoor unit and outdoor unit and Central controller wiring.
- To prevent noise trouble, use 2-core shield wire.

■ Communication line

TU2C-Link models (U series) can be combined with TCC-Link models (other than U series).
For details of communication type, refer to the following table.

Communication type and model names

Communication type	TU2C-Link (U series and future models)	TCC-Link (Other than U series)
Outdoor unit	MMY-MUP***, MMY-SUC*** ↑ This letter indicates U series model.	Other than U series MMY-MAP*** MCY-MHP***
Indoor unit	MM*-UP*** ↑ This letter indicates U series model.	Other than U series MM*-AP***
Hot Water Module	MMW*-UP*** ↑ This letter indicates U series model.	Other than U series MMW-AP***
Wired remote controller	RBC-A**U*** ↑ This letter indicates U series model.	Other than U series

U series outdoor unit: SMMS-u, SHRM-A

Other than U series outdoor unit: SMMS-e, SHRM-e, MiNi-SMMS-e

<In the case of combining with U series outdoor unit>

Follow the wiring specifications in the table below even when units other than U series are mixed in the indoor units and remote controllers to be connected.

Uv line and Uc line (L2, L3, L4) (2-core shield wire, non-polarity)	Wire size: 1.0 to 1.5 mm ² (Up to 1000 m)
Uh line (L1) (2-core shield wire, non-polarity)	Wire size: 1.0 to 1.5 mm ² (Up to 1000 m) 2.0 mm ² (Up to 2000 m)

- **U (v, h, c)** line means of control wiring.
 - Uv line:** Between indoor and outdoor units.
 - Uh line:** Central control line.
 - Uc line:** Between outdoor and outdoor units.
- **Uv line and Uc line** are independent from another refrigerant line. Total length of **Uv** and **Uc** lines (**L3 + L4**) in each refrigerant line is up to 1000 m.

REQUIREMENT

For connection of Uv line / Uc line or Uh line, wire each line using wires with the same type and size. If different wire types and size are mixed and used in a system, communication trouble is caused.

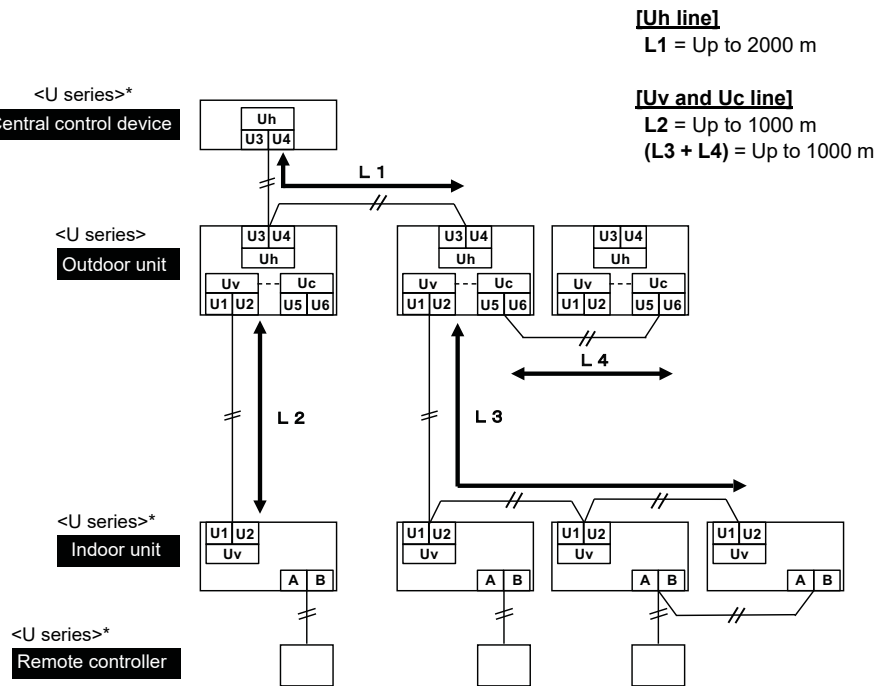

*Even if the indoor units, the remote controllers, and the central control device are models other than U series, their system diagrams for the wiring specifications are the same as the system diagram above.

<In the case of combining with outdoor units other than U series outdoor unit>

Control wiring between indoor units, and outdoor unit (L2, L3) (2-core shield wire, non-polarity)	Wire size: 1.25 mm ² (Up to 1000 m)
Central control line wiring (L1) (2-core shield wire, non-polarity)	Wire size: 2.0 mm ² (Up to 2000 m)
Control wiring between outdoor units (L4) (2-core shield wire, non-polarity)	Wire size: 1.25 to 2.0 mm ² (Up to 100 m)

- The length of the communication line (**L1 + L2 + L3**) means the total length of the inter-unit wire length between indoor and outdoor units added with the central control system wire length.

REQUIREMENT

For connection of between indoor and outdoor units line / between outdoor and outdoor units line or central control line, wire each line using wires with the same type and size. If different wire types and size are mixed and used in a system, communication trouble is caused.

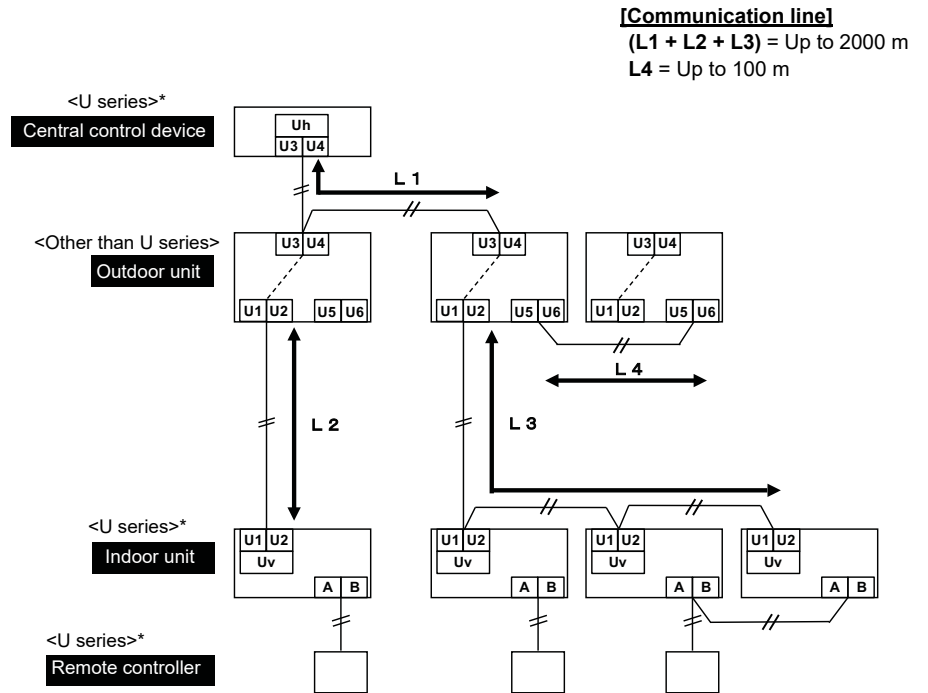

*Even if the indoor units, the remote controllers, and the central control device are models other than U series, their system diagrams for the wiring specifications are the same as the system diagram above.

Remote controller wiring

- 2-core with non-polarity wire is used for the remote controller wiring and group remote controllers wiring.

Remote controller wiring, remote controller inter-unit wiring	Wire size: 0.5 mm ² to 2.0 mm ²	
Total wire length of remote controller wiring and remote controller inter-unit wiring = L + L1 + L2 + ... Ln	In case of one remote controller	Up to 500 m
	In case of two remote controller	Up to 400 m
Max. length of each remote control wiring between indoor units = L1, L2, ... , Ln	Up to 200 m	

CAUTION

- The remote controller wire (Communication line) and AC 220 - 240 V wires cannot be parallel to contact each other and cannot be stored in the same conduits. If doing so, a trouble may be caused on the control system due to noise or other factor.
- If U series models (TU2C-Link) are combined with models other than U series (TCC-Link), the wiring specifications and maximum number of connectable indoor units will be changed. Pay attentions to their communication specifications when carrying out the installation, maintenance, or repair. For its details, refer to the "Communication line" in 9 Electrical connection.

M-HWM: Mid temperature Hot Water Module
H-HWM: High temperature Hot Water Module

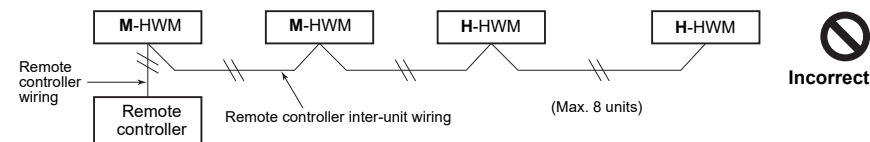
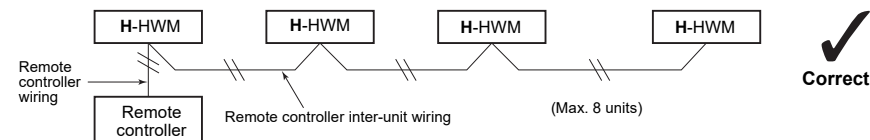
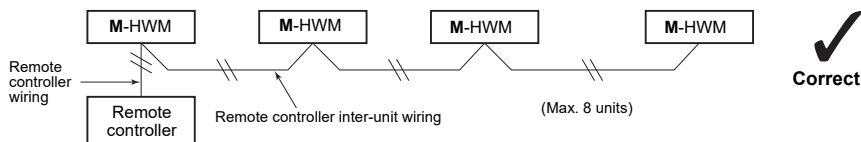
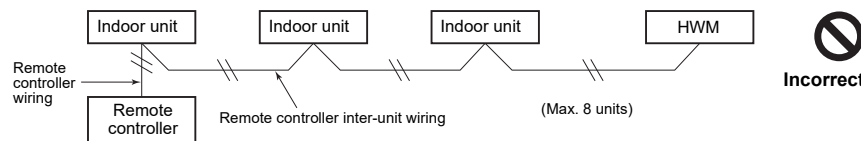
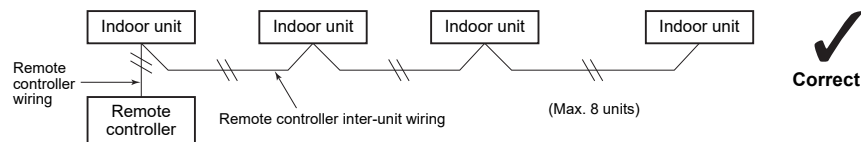

(*): In the case of multiple refrigerant systems

NOTE

It is not possible to connect HWM and any indoor units together for group control.
It is not possible to connect M-HWM and H-HWM together for group control.

Max. number of connectable indoor units, and communication type

Outdoor unit	Unit type							
	U series	U series	U series	U series	*	*	*	*
Indoor unit	U series	U series	*	*	U series	U series	*	*
Remote controller	U series	*	U series	*	U series	*	U series	*
Communication type	TU2C-Link		TCC-Link					
Max. number of connectable units	16		8					

*: Other than U series

REQUIREMENT

After carrying out installation of additional indoor unit, relocation, or repairing, set the addresses again.
For its detail, refer to the Installation Manual attached to the outdoor unit.

■ Wiring between indoor (including hot water module) and outdoor units

NOTE

A wiring diagram below is an example for connection to SMMS-u series. For connecting to other outdoor unit series, refer to the Installation Manual attached to the outdoor unit to be connected.

▼ Wiring example

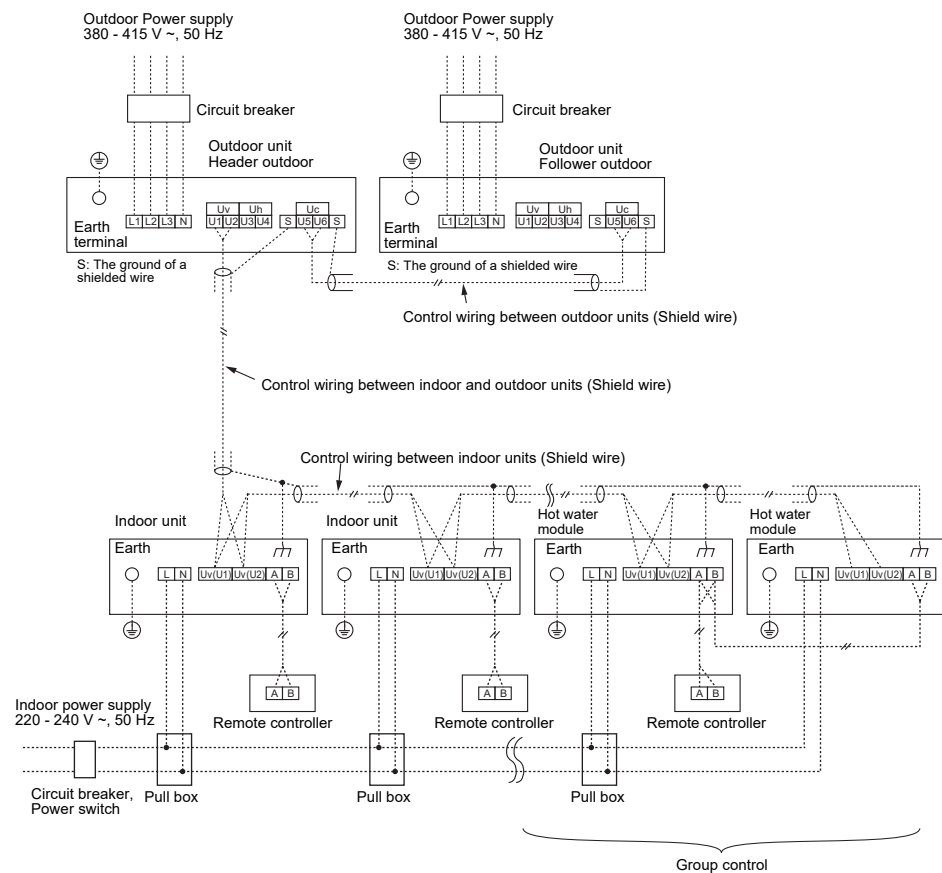

■ Wire connection

REQUIREMENT

- Connect the wires matching the terminal numbers. Incorrect connection causes a trouble.
 - Pass the wires through the bushing of wire connection holes of the hot water module.
 - Keep a margin (Approx. 100 mm) on a wire to hang down the electrical control box at servicing or other purpose.
 - The low-voltage circuit is provided for the remote controller. (Do not connect the high-voltage circuit)
-
- Remove the front panel of the hot water module by taking off the mounting screws (2 positions).
 - Tighten the screws of the terminal block, and fix the wires with cord clamp attached to the electrical control box. (Do not apply tension to the connecting section of the terminal block.)
 - Mount the front panel of the hot water module without pinching wires.

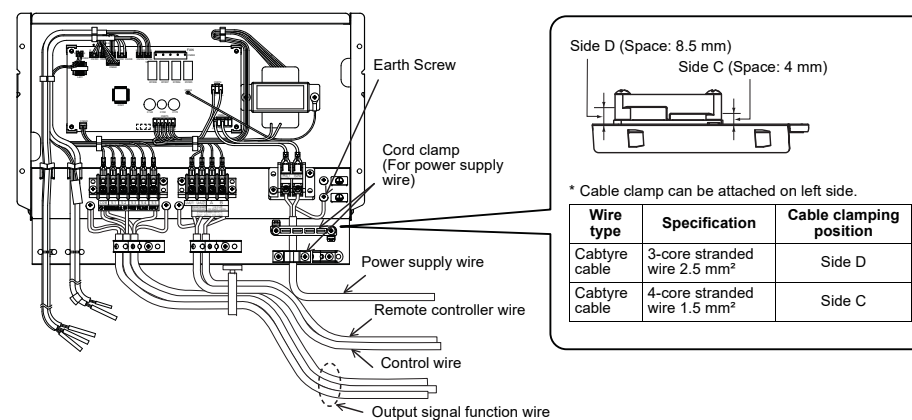
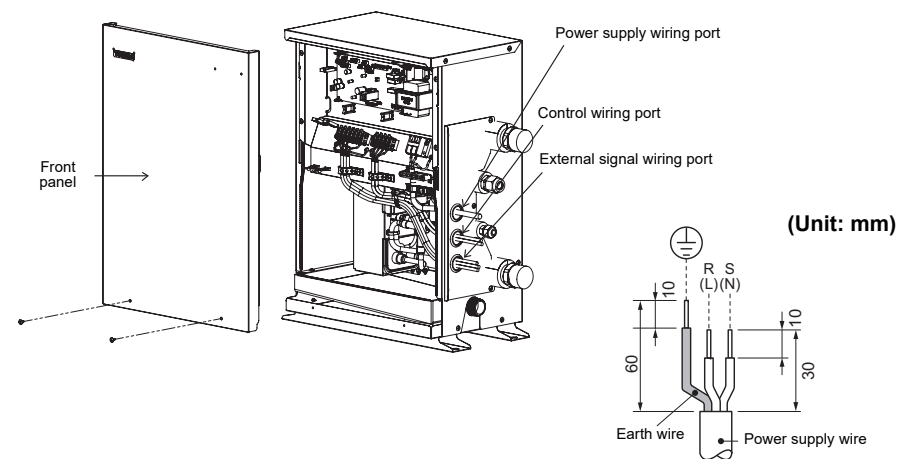

■ Wiring for Flow selector unit (FS unit) for SHRM-e and SHRM-A

Connect communication wire of FS unit to terminal A, B (no polarity) of Hot Water Module, when the Hot water module connects to SHRM-e and SHRM-A system.

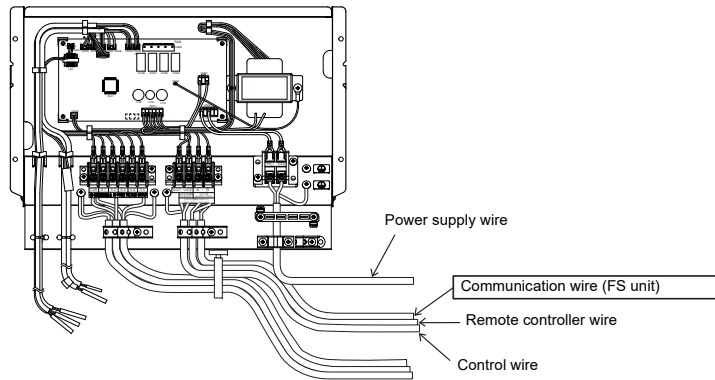

NOTE

In case of connecting at least one Hot Water Module in SHRM-e and SHRM-A system, all of FS units in the system should be Single port type FS unit (long piping model) or Multiport type FS unit.

■ Remote controller wiring

Strip off approx. 9 mm the wire to be connected.

▼ Wiring diagram

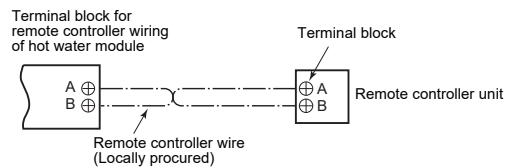

■ Output signal function wiring

Connect the following output signals from the hot water module.

Terminal block No.	Function	Comments
COM	DC12 V (COM)	Common for connector S2 ~ S5
S1	Defrosting output (COM-S1)	DC12 V Relay coil is less than 16 mA.
S2	Line heater output (COM-S2)	DC12 V Relay coil is less than 16 mA.
S3	-	-
S4	Heating thermostat ON output (COM-S4)	DC12 V Relay coil is less than 16 mA.
S5	Pump output (COM-S5)	DC12 V Relay coil is less than 16 mA.

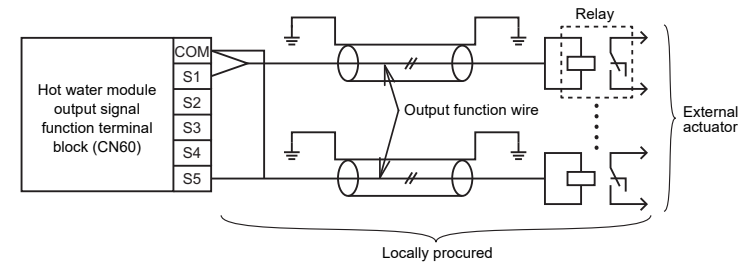

NOTE

Auxiliary relays (locally procured) must be connected to output signal function wirings to allow connection to the hot water module output signal functions. The maximum current output signal, from each of the output signal function wirings, is 16 mA. Please ensure the rated current of the relay coil is less than 16 mA to avoid damage to the hot water module P.C. board.

▼ Output function wire

⚠ CAUTION

Output signal functions are separated from primary basic insulation.

- To prevent noise trouble, use 2-core shield wire.
- Determine the wire length between the hot water module output signal function terminal block and the relay up to 2 m.
- Locally procure and install protective devices such as the heater and pump.

■ Address setup

Set up the addresses as per the Installation Manual supplied with the outdoor unit.

⚠ CAUTION

Set DIP switch 4 of SW09 or SW103 on the P.C. board of the header outdoor unit to ON.
(The factory default is OFF)

VRF system will be stopped to avoid water freezing when the power supply is disconnected.

<SMMS-i, SMMS-e and MiNi SMMS (MCY)>

Set DIP switch 4 of SW09 on the P.C. board of the header outdoor unit to ON. (The factory default is OFF)

Interface P.C. board on the header outdoor unit



<SMMS-u series>

Set DIP switch 4 of SW103 on the P.C. board of the header outdoor unit to ON. (The factory default is OFF)

Interface P.C. board on the header outdoor unit

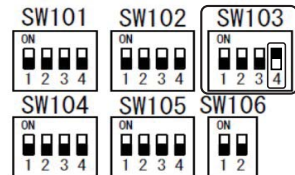

- The <SHRM-A series> does not require of this DIP switch operation.

■ Setting method for 115 to 200% connection compared to outdoor unit capacity (Only SMMS-i, SMMS-e and SMMS-u operate separately)

Relative to outdoor unit capacity, when the connection capacity of HWM+FCU (indoor unit) is 115 to 200% (but $HWM \leq FCU$), the following settings should be made.

<SMMS-i and SMMS-e series>

Set DIP switch 2 of SW09 on the P.C. board of the header outdoor unit to ON. (The factory default is OFF)

Interface P.C. board on the header outdoor unit

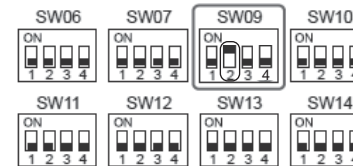

<SMMS-u series>

Set DIP switch 3 of SW103 on the P.C. board of the header outdoor unit to ON. (The factory default is OFF)

Interface P.C. board on the header outdoor unit

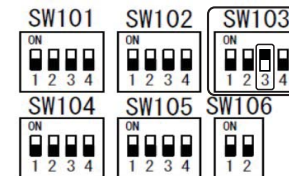

⚠ WARNING

Do not make more than 200% of the connection compared to outdoor unit capacity. Otherwise, it may cause failure and performance degradation.

10 Applicable controls

REQUIREMENT

When the air conditioner (including the Hot water module) is used for the first time, it will take some moments after the power has been turned on before the remote controller becomes available for operations: This is normal and is not indicative of trouble.

- Concerning the automatic addresses (The automatic addresses are set up by performing operations on the outdoor interface circuit board.)
While the automatic addresses are being set up, no remote controller operations can be performed. Setup takes up to 10 minutes (usually about 5 minutes).
- When the power is turned on after automatically address setup, it takes up to 10 minutes (usually about 3 minute) for the outdoor unit to start operating after the power has been turned on.

Before the air conditioner (including the Hot water module) was shipped from the factory, all units are set to [STANDARD] (factory default). If necessary, change the indoor unit settings.

The settings are changed by operating the wired remote controller.

■ Applicable controls setup (settings at the site)

Remote controller model name:
RBC-ASCU1 ✧

Basic procedure

Be sure to stop the air conditioner (including the Hot water module) before making settings.

(Change the setup while the air conditioner (including the Hot water module) is not working.)

⚠ CAUTION

Set only the Code No. shown in the following table: Do NOT set any other Code No.

If a Code No. not listed is set, it may not be possible to operate the air conditioner or other trouble with the product may result.

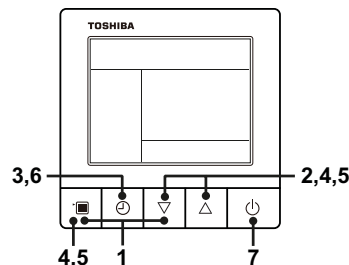

1 Push and hold menu button and [▽] setting button simultaneously for 10 seconds or more.

- After a while, the display flashes as shown in the figure. "ALL" is displayed as indoor unit numbers during initial communication immediately after the power has been turned on.

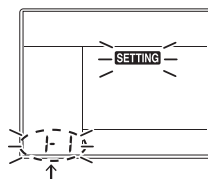

2 Each time [▽] [△] setting button is pushed, indoor unit numbers in the group control change cyclically. Select the indoor unit to change settings for.

The LED indicator on the printed circuit board of the selected hot water module flashes. You can confirm the change settings of the module.

Printed circuit board of the hot water module

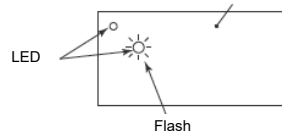

3 Push OFF timer button to confirm the selected indoor unit.

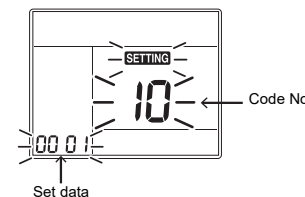

4 Push the menu button to make Code No. [] flash. Change Code No. [**] with [▽] [△] setting button.**

5 Push the menu button to make Set data [**] flash. Change Set data [****] with [▽] [△] setting button.**

6 Push OFF timer button to complete the set up.
 • To change other settings of the selected indoor unit, repeat from Procedure 4.

7 When all the settings have been completed, push ON/OFF button to finish the settings. (Return to the normal mode).
 "SETTING" flashes and then the display content disappears and the air conditioner enters the normal stop mode. (The remote controller is unavailable while "SETTING" is flashing.)
 • To change settings of another indoor unit, repeat from Procedure 1.

■ Group control

In a group control, a remote controller can control up to maximum 8 or 16 units. (Depending on the outdoor unit.)

- For wiring procedure and wires of the individual line (Identical refrigerant line) system, refer to "9. Electrical connection" in this Manual.
- Wiring between indoor units in a group is performed in the following procedure.
- Connect the indoor units by connecting the remote controller wires from the remote controller terminal blocks (A, B) of the indoor unit connected with a remote controller to the remote controller terminal blocks (A, B) of the other indoor unit. (Non-polarity)
- For address setup, refer to the Installation Manual attached to the outdoor unit.

11 Test run

■ Before test run

- Before turning on the circuit breaker, carry out the following procedure.
 - By using insulation tester (500 VMΩ), check that resistance of 1 MΩ or more exists between the terminal block L to N and the earth (grounding). If resistance of less than 1 MΩ is detected, do not run the unit.
 - Check the valve of the outdoor unit that is fully open.
- To protect the compressor at start-up, turn on the power supply 12 hours or more before operation.
- Before starting the test run, follow the Installation Manual included with the outdoor unit to set the address.
- The water supply to the water piping system (above 10°C) should be completed and the pump should be wired prior to the test run. When water is not supplied to hot water module, and when the water does not circulate, the entire system will stop with an error detected (check code: A01).

■ Perform test run

Use the wired remote controller to operate the unit as usual.

For procedures of this operation, refer to the Owner's Manual.

A forced test run can be executed in the following procedure even if the operation stops by thermostat-OFF. In order to prevent a serial operation, the forced test run is released after 60 minutes have passed and returns to the usual operation.

⚠ WARNING

Do not use the forced test run for modes other than test run, as this will put excessive loads on the device.

Wired remote controller

Be sure to stop the air conditioner (including the Hot water module) before making settings.

(Change the setup while the air conditioner is not working.)

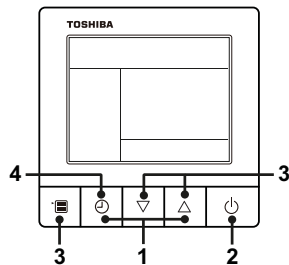

- Push and hold OFF timer button and [△] setting button simultaneously for 10 seconds or more. [TEST] is displayed on the display part and the test run is permitted.

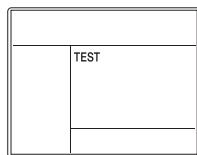

- Push ON/OFF button.
- Push the menu button to heating mode .
 - The temperature setting function does not work during test run.
 - The check code is displayed as usual.
- After the test run, push OFF timer button to stop a test run. ([TEST] disappears on the display and the air conditioner enters the normal stop mode.)

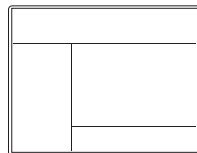

■ Items to check before conducting a test run

Check the following items before the test run. The numbers in (parentheses) are the chapter numbers in the table of contents of the installation manual.

		Check
Installation work	Is the equipment attached to the legs with bolts? (See chapter 5.)	
	Is there sufficient open space around the equipment for servicing? (See chapter 4.)	
	Have the criteria for selecting a location to install the equipment been met? (See chapter 4.)	
Piping work	Are all of the pipes connected correctly? (See chapter 6 to 8.)	
	Are there no water leaks?	
	Is the flow rate suitable? (See chapter 6.)	
	Is the strainer in a suitable location? (See chapters 3 and 6.)	
	Is the line heater in a suitable location and is the flow rate suitable? (See chapters 3 and 6.)	
	Have suitable safety devices for pressure relief and expansion tanks been installed? (See chapters 3 and 6.)	
	Is the shut-off valve in a suitable location? (See chapters 3 and 6.)	
	Is the air vent valve in a suitable location? (See chapters 3 and 6.)	
Electric wiring work	Is the piping material suitably heat resistant and corrosion resistant? (See chapters 6 to 8.)	
	Can water discharge through the drain? (See chapter 7.)	
	Was the heat-retention work done suitably? (See chapters 6 to 8.)	
	Is the electric wiring connected correctly? (See chapter 9.)	
	Is the electric wiring thick enough? (See chapter 9.)	
Outdoor unit board settings	Is the power fed from a dedicated ground fault circuit breaker?	
	Is the output terminal wired? (See chapter 9.)	
	Is the addressed fixed? (*1)	
	Has DIP switch 4 of SW09 or SW103 on the interface board of the header outdoor unit been set to "ON" (factory default is "OFF")? (See chapter 9.) (*2)	

*1 Do not operate the air conditioner (run the compressor) before the address to the hot water module is fixed. Doing so will cause the heat exchanger in the hot water module to freeze, rupture, and leak water.

*2 Set DIP switch 4 of SW09 or SW103 on the P.C. board of the header outdoor unit to "ON" (factory default is "OFF"). The VRF system will be stopped to avoid water freezing when the power supply is disconnected.

NOTE

Before you run the compressor, always confirm that the hot water module is operable (power on, address fixed, communication wiring complete).

Failure to do this will cause the heat exchanger in the hot water module to freeze, rupture, and leak water.

12 Maintenance

▼ Periodic Maintenance

- For environmental conservation, it is strongly recommended that the indoor and outdoor units of the air conditioner (including hot water module) in use be cleaned and maintained regularly to ensure efficient operation of the air conditioner.
When the air conditioner (including hot water module) is operated for a long time, periodic maintenance (once a year) is recommended.
Furthermore, regularly check the outdoor unit for rust and scratches, and remove them or apply rustproof treatment, if necessary.
As a general rule, when an indoor unit is operated for 8 hours or more daily, clean the indoor unit and outdoor unit at least once every 3 months. Ask a professional for this cleaning / maintenance work.
Such maintenance can extend the life of the product though it involves the owner's expense.
Failure to clean the indoor and outdoor units regularly will result in poor performance, freezing, water leakage, and even compressor failure.

Inspection before maintenance

Following inspection must be carried out by a qualified installer or qualified service person.

Parts	Inspection method
Drain pan	Access from inspection opening and remove the front panel. Check if there is any clogging or drain water is polluted.

▼ Maintenance List

Part	Unit	Check (visual / auditory)	Maintenance
Heat exchanger	Outdoor	Dust / dirt clogging, scratches	Wash the heat exchanger when it is clogged.
Fan motor	Outdoor	Sound	Take appropriate measures when abnormal sound is generated.
Air inlet / outlet grilles	Outdoor	Dust / dirt, scratches	Fix or replace them when they are deformed or damaged.
Drain pan	Hot water module	Dust / dirt clogging, drain contamination	Clean the drain pan and check the downward slope for smooth drainage.
Exterior	Hot water module / Outdoor	<ul style="list-style-type: none"> Rust, peeling of insulator Peeling / lift of coat 	Apply repair coating.
Water pipes	Hot water module	Rust, leakage Evidence of leakage	Checking
Strainer	Hot water module	Dust / dirt clogging	Checking
Air vent valve	Hot water module	Air entrainment	Checking an air vent valve

It recommends that a pump and a strainer are maintained periodically.

13 Troubleshooting

■ Confirmation and check

If a problem occurs with the air conditioner (including the Hot water module), the OFF timer indicator alternately shows the check code and the indoor Unit No. in which the problem occurred.

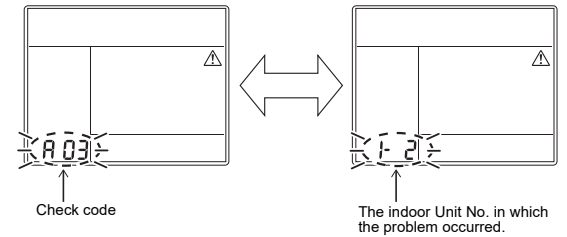

■ Troubleshooting history and confirmation

You can check the troubleshooting history with the following procedure if a problem occurs with the air conditioner (including the Hot water module).

(The troubleshooting history records up to 4 incidents.)

You can check it during operation or when operation is stopped.

- If you check the troubleshooting history during OFF timer operation, the OFF timer will be canceled.

Procedure	Description of operation
1	<p>Push the OFF timer button for over 10 seconds and the indicators appear as an image indicating the troubleshooting history mode has been entered. If [Service check] is displayed, the mode enters in the troubleshooting history mode.</p> <ul style="list-style-type: none"> [01: Order of troubleshooting history] appears in the temperature indicator. The OFF timer indicator alternately shows the [check code] and the [indoor Unit No.] in which the problem occurred.
2	<p>Each time the setting button is pushed, the recorded troubleshooting history is displayed in sequence. The troubleshooting history appears in order from [01] (newest) to [04] (oldest).</p> <p>CAUTION</p> <p>In the troubleshooting history mode, DO NOT push the Menu button for over 10 seconds, doing so deletes the entire troubleshooting history of the indoor unit.</p>
3	<p>After you have finished checking, push the ON/OFF button to return to the regular mode.</p> <ul style="list-style-type: none"> If the air conditioner (including the Hot water module) is operating, it remains operated even after the ON/OFF button has been pushed. To stop its operation, push the ON/OFF button again.

Check method

On the wired remote controller, central control remote controller and the interface P.C. board of the outdoor unit (I/F), a check display LCD (Remote controller) or 7-segment display (on the outdoor interface P.C. board) to display the operation is provided. Therefore the operation status can be known. Using this self-diagnosis function, a trouble or position with trouble of the air conditioner (including the Hot water module) can be found as shown in the following table.

Check code list

The following list shows each check code. Find the check contents from the list according to part to be checked.

- In case of check from indoor remote controller: See "Wired remote controller display" in the list.
- In case of check from outdoor unit: See "Outdoor unit 7-segment display" in the list.

Indoor unit: Including of Hot water module.
I/F: Interface P.C. board

Wired remote controller display	Check code		Check code name	Judging device
	Outdoor unit 7-segment display			
		Auxiliary code		
E01	—	—	Communication trouble between indoor unit and remote controller (Detected at remote controller side)	Remote controller
E02	—	—	Remote controller transmission trouble	Remote controller
E03	—	—	Communication trouble between indoor unit and remote controller (Detected at indoor unit side)	Indoor unit
E04	—	—	Communication circuit trouble between indoor / outdoor unit (Detected at indoor unit side)	Indoor unit
E06	E06	No. of indoor units in which sensor has been normally received	Decrease of No. of indoor units	I/F
—	E07	—	Communication circuit trouble between indoor / outdoor unit (Detected at outdoor unit side)	I/F
E08	E08	Duplicated indoor unit addresses	Duplicated indoor unit addresses	Indoor unit • I/F
E09	—	—	Duplicated master remote controllers	Remote controller
E10	—	—	Communication trouble between indoor unit MCU	Indoor unit
E12	E12	01: Indoor/Outdoor units communication 02: Outdoor/Outdoor units communication	Automatic address start trouble	I/F
E15	E15	—	No indoor unit during automatic addressing	I/F
E16	E16	00: Capacity over 01 ~: No. of connected units	Capacity over / No. of connected indoor units	I/F
E17	—	—	Communication trouble between indoor unit and Flow Selector unit	Indoor unit
E18	—	—	Communication trouble between header and follower units Indoor unit	Indoor unit
E19	E19	00: Header is not detected 02: Two or more header units	Outdoor header units quantity trouble	I/F
E20	E20	01: Outdoor unit of other line connected 02: Indoor unit of other line connected	Other line connected during automatic address	I/F
E23	E23	—	Sending trouble in communication between outdoor units Trouble in number of heat storage units (trouble with reception)	I/F
E25	E25	—	Duplicated follower outdoor addresses	I/F
E26	E26	No. of outdoor units which received signal normally	Decrease of No. of connected outdoor units	I/F
E28	E28	Detected outdoor unit number	Follower outdoor unit trouble	I/F
E31	E31	*1 Inverter quantity information	Inverter communication trouble	I/F
F01	—	—	Indoor unit TCJ sensor trouble	Indoor unit
F02	—	—	Indoor unit TC2 sensor trouble	Indoor unit
F03	—	—	Indoor unit TC1 sensor trouble	Indoor unit
F04	F04	—	TD1 sensor trouble	I/F
F05	F05	—	TD2 sensor trouble	I/F
F06	F06	01: TE1 sensor 02: TE2 sensor 03: TE3 sensor	TE1, TE2 or TE3 sensor trouble	I/F

Check code			Check code name	Judging device
Wired remote controller display	Outdoor unit 7-segment display			
		Auxiliary code		
F07	F07	01: TL1 sensor 02: TL2 sensor 03: TL3 sensor	TL1,TL2 or TL3 sensor trouble	I/F
F08	F08	—	TO sensor trouble	I/F
F09	F09	01: TG1 sensor 02: TG2 sensor 03: TG3 sensor	TG1,TG2 or TG3 sensor trouble	I/F
F10	—	—	Indoor unit TA sensor trouble	Indoor unit
F12	F12	01: TS1 sensor 03: TS3 sensor 04: TS3 sensor disconnect	TS1 or TS3 sensor trouble	I/F
F13	F13	1*: Compressor 1 side 2*: Compressor 2 side	TH sensor trouble	Compressor inverter
F15	F15	—	Outdoor unit temp. sensor miswiring (TE, TL)	I/F
F16	F16	—	Outdoor unit pressure sensor miswiring (Pd, Ps)	I/F
F19	—	—	Hot water module TCJ2 (TF) sensor trouble	Hot water module
F22	F22	—	TD3 sensor trouble	I/F
F23	F23	—	Ps sensor trouble	I/F
F24	F24	—	Pd sensor trouble	I/F
F25	—	—	Hot water module TWI (TA) sensor trouble	Hot water module
F26	—	—	Hot water module TWO (TC2) sensor trouble	Hot water module
F29	—	—	Indoor unit other trouble	Indoor unit
F31	F31	—	Indoor unit EEPROM trouble	I/F
H01	H01	1*: Compressor 1 side 2*: Compressor 2 side	Compressor break down	Compressor inverter
H02	H02	1*: Compressor 1 side 2*: Compressor 2 side	Compressor trouble (lock)	Compressor inverter
H03	H03	1*: Compressor 1 side 2*: Compressor 2 side	Current detect circuit system trouble	Compressor inverter
H04	H04	—	Compressor 1 case thermostat operation	I/F
H05	H05	—	TD1 sensor miswiring	I/F
H06	H06	—	Low pressure protective operation	I/F
H07	H07	—	Oil level down detective protection	I/F
H08	H08	01: TK1 sensor trouble 02: TK2 sensor trouble 03: TK3 sensor trouble 04: TK4 sensor trouble 05: TK5 sensor trouble	Oil level detective temp. sensor trouble	I/F
H14	H14	—	Compressor 2 case thermostat operation	I/F
H15	H15	—	TD2 sensor miswiring	I/F
H16	H16	01: TK1 oil circuit system trouble 02: TK2 oil circuit system trouble 03: TK3 oil circuit system trouble 04: TK4 oil circuit system trouble 05: TK5 oil circuit system trouble	Oil level detective circuit trouble	I/F
H17	H17	1*: Compressor 1 side 2*: Compressor 2 side	Compressor trouble (step-out)	Compressor inverter
H25	H25	—	TD3 sensor miswiring	I/F
J02	—	—	Communication trouble between control boards in Flow Selector unit	Indoor unit
J03	—	—	Duplicated Flow Selector unit addresses	Indoor unit

Check code			Check code name	Judging device
Wired remote controller display	Outdoor unit 7-segment display			
		Auxiliary code		
J10	J10	Detected indoor unit address	Flow Selector unit overflow trouble	Indoor unit
J11	—	—	Flow Selector unit temperature sensor (TCS) trouble	Indoor unit
L02	—	—	Model mismatch of outdoor unit	Hot water module
L03	—	—	Indoor unit header unit duplicated	Indoor unit
L04	L04	—	Outdoor unit line address duplicated	I/F
L05	—	—	Duplicated indoor units with priority (Displayed in indoor unit with priority)	I/F
L06	L06	No. of indoor units with priority	Duplicated indoor units with priority (Displayed in unit other than indoor unit with priority)	I/F
L07	—	—	Group line in individual indoor unit	Indoor unit
L08	L08	—	Indoor unit group/Address unset	Indoor unit, I/F
L09	—	—	Indoor unit capacity unset	Indoor unit
L10	L10	—	Outdoor unit capacity unset	I/F
L11	L11	Detected indoor unit address	Flow Selector unit not connected	I/F
L12	L12	01: Flow Selector unit installation trouble	Flow Selector unit system trouble	I/F
L13	L13	Detected indoor unit address	Safety device setting unmatch	I/F
L14	L14	Detected indoor unit address	Safety device nonconformity	I/F
L17	L17	—	Outdoor unit type mismatch trouble	I/F
L18	L18	Detected indoor unit address	Flow Selector unit trouble	I/F
L20	—	—	Duplicated central control addresses	Indoor unit
L22	—	—	There is a DX-kit (heat source capacity command) non-compliant machine in the group (DDC control, TA control and TF control are mixed)	Indoor unit
L23	—	02: Hot water module setting trouble	Setting trouble	I/F
L24	L24	01: Duplication of Flow Selector unit address 02: Indoor unit operation mode priority setting	Flow Selector unit setting trouble	I/F
L28	L28	—	Too many outdoor units connected	I/F
L29	L29	*1 Inverter quantity information	No. of inverter trouble	I/F
L30	L30	Detected indoor unit address	Indoor unit outside interlock	Indoor unit
—	L31	—	Extended I/C trouble	I/F
P01	—	—	Indoor fan motor trouble	Indoor unit
P03	P03	—	Discharge temp. TD1 trouble	I/F
P04	P04	1*: Compressor 1 side 2*: Compressor 2 side	High-pressure SW system operation	Compressor inverter, I/F
P05	P05	1*: Compressor 1 side 2*: Compressor 2 side	Phase missing detection/Power failure detection Inverter DC voltage trouble (compressor)	I/F
P07	P07	1*: Compressor 1 side 2*: Compressor 2 side	Heat sink overheat trouble	Compressor inverter, I/F
		04: Heat sink	Heat sink dew condensation trouble	
P11	P11	—	Outdoor heat exchanger freezing trouble	I/F
P13	P13	—	Outdoor liquid back detection trouble	I/F
P14	P14	01: Outdoor unit valve is closed	Another refrigerant cycle protection	I/F
P15	P15	01: TS condition 02: TD condition	Gas leak detection	I/F
P16	P16	01: PMV5 02: PMV6 03: SV7	Injection circuit trouble	I/F
P17	P17	—	Discharge temp. TD2 trouble	I/F
P18	P18	—	Discharge temp. TD3 trouble	I/F

Check code			Check code name	Judging device
Wired remote controller display	Outdoor unit 7-segment display			
		Auxiliary code		
P19	P19	0#: 4-way valves 1#: 4-way valve1 2#: 4-way valve2 *Put in outdoor unit No. in [#] mark.	4-way valve inverse trouble	I/F
P20	P20	—	High-pressure protective operation	I/F
P22	P22	1*: Compressor 1 side 2*: Compressor 2 side	Outdoor unit fan inverter trouble	Fan inverter
P26	P26	1*: Compressor 1 side 2*: Compressor 2 side	IPM short protection trouble	Compressor inverter
P29	P29	1*: Compressor 1 side 2*: Compressor 2 side	Compressor position detective circuit system trouble	Compressor inverter
P31	—	—	Other indoor unit trouble (Group follower indoor unit trouble)	Indoor unit
A01	A01	Detected Hot water module address	Flow switch operation trouble	Hot water module
A02	A02	Detected Hot water module address	Water temperature decrease trouble	Hot water module
A04	A04	Detected Hot water module address	Activation of water heat exchanger frost protection	Hot water module

***1 Inverter quantity information**
(SMMS-e, SMMS-u, SHRM-A)

- For details about check codes determined with an Interface P.C board or an Inverter P.C board, refer to the Installation Manual of the outdoor unit.
- For details about check codes of MiNi SMMS (MCY), refer to the Installation Manual of the outdoor unit.

No.	Compressor Inverter			Fan Inverter	Trouble
	1	2	3		
01	○				Comp. 1
02		○			Comp. 2
03	○	○			Comp. 1 + Comp. 2
04			○		Comp. 3
05	○		○		Comp. 1 + Comp. 3
06		○	○		Comp. 2 + Comp. 3
07	○	○	○		Comp. 1 + Comp. 2 + Comp. 3
08				○	Fan
09	○			○	Comp. 1 + Fan
0A		○		○	Comp. 2 + Fan
0B	○	○		○	Comp. 1 + Comp. 2 + Fan
0C			○	○	Comp. 3 + Fan
0D	○		○	○	Comp. 1 + Comp. 3 + Fan
0E		○	○	○	Comp. 2 + Comp. 3 + Fan
0F	○	○	○	○	All

○: Inverter trouble

Trouble detected by central control device

Check code			Check code name	Judging device
Central control device indication	Outdoor unit 7-segment display			
		Auxiliary code		
C05	—	—	Sending trouble in central control device	Central control device
C06	—	—	Receiving trouble in central control device	Central control device
C12	—	—	Batch alarm of general-purpose equipment control interface	General-purpose equipment I/F
P30 (L20)	Differs according to trouble contents of unit with occurrence of alarm		Group control follower unit trouble	Central control device
	—	—	Duplication addresses of indoor units in central control device	
S01	—	—	Receiving trouble in central control device	Central control device

14 Notice code

- Notice code is a function only in TC2U-Link communication.
- When the outdoor or indoor unit detects its conditions requiring caution or maintenance, this function notifies you to check your units with the spanner mark (Notice code mark) on the wired remote controller or central controller display.
- Even while the notice code mark is displayed, the air conditioner can operate normally.
- A maximum of 5 notice codes can be issued simultaneously in one system (line).

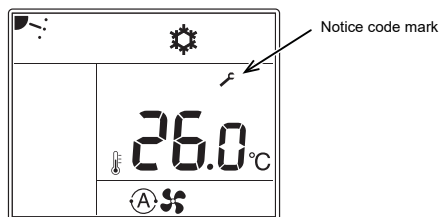

■ How to check Notice code No.

- 1** Stop the operation of the air conditioner and push the Menu button and OFF timer button at the same time for 10 seconds or more.
- 2** The unit number of the indoor unit is displayed at the bottom left of the screen.
Change it with the [▽] [△] setting button and push the OFF timer button to confirm.
- 3** The history number is displayed in the center of the screen, and the Notice code No. is displayed in the lower left.
[▽] [△] You can switch the history with the setting button (a maximum of 5 notice codes).
- 4** Push the ON / OFF button to return to the operation stop screen.

■ Notice code list

Notice code No.	Item	Content
203	Flow Selector unit battery dead	The battery kit connected to the Flow Selector unit has reached the end of its life.

WARNINGS ON REFRIGERANT LEAKAGE

Check of Concentration Limit

The room in which the air conditioner (including hot water module) is to be installed requires a design that in the event of refrigerant gas leaking out, its concentration will not exceed a set limit.

Refrigerant R32

The refrigerant R32 which is used in the air conditioner (including hot water module) is mildly flammable. In Europe and areas where IEC standards apply, EN/IEC 60335-2-40 is the applicable standard. The refrigerant R32 does not have the toxicity of ammonia, and is not restricted by laws to be imposed which protect the ozone layer. If this appliance is connected with the outdoor unit containing R32 refrigerant, refer to the Installation and Owner's Manual attached to the outdoor unit.

Refrigerant R410A

The refrigerant R410A which is used in the air conditioner (including hot water module) is safe, without the toxicity or combustibility of ammonia, and is not restricted by laws to be imposed which protect the ozone layer. However, since it contains more than air, it poses the risk of suffocation if its concentration should rise excessively. Suffocation from leakage of R410A is almost non-existent. With the recent increase in the number of high concentration buildings, however, the installation of multi air conditioner systems (including hot water module) is on the increase because of the need for effective use of floor space, individual control, energy conservation by curtailing heat and carrying power etc.

Most importantly, the multi air conditioner system (including hot water module) is able to replenish a large amount of refrigerant compared with conventional individual air conditioners (including hot water module). If a single unit of the multi conditioner system is to be installed in a small room, select a suitable model and installation procedure so that if the refrigerant accidentally leaks out, its concentration does not reach the limit (and in the event of an emergency, measures can be made before injury can occur).

In a room where the concentration may exceed the limit, create an opening with adjacent rooms, or install mechanical ventilation combined with a gas leak detection device.

The concentration is as given below.

$$\frac{\text{Total amount of refrigerant (kg)}}{\text{Min. volume of the indoor unit (including hot water module) installed room (m}^3\text{)}} \leq \text{Concentration limit (kg/m}^3\text{)}$$

Refrigerant Concentration Limit shall be in accordance with local regulations.

▼ NOTE 1

If there are 2 or more refrigerating systems in a single refrigerating device, the amounts of refrigerant should be as charged in each independent device.

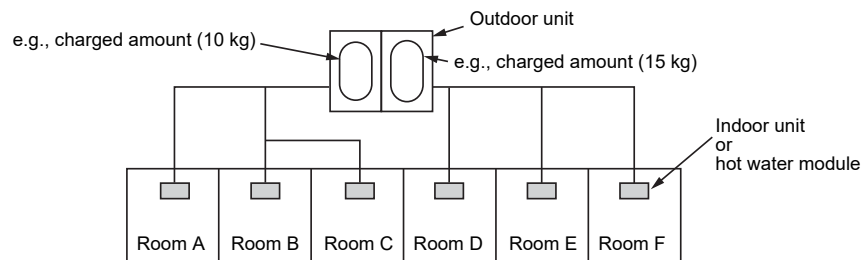

For the amount of charge in this example:

The possible amount of leaked refrigerant gas in rooms A, B and C is 10 kg.

The possible amount of leaked refrigerant gas in rooms D, E and F is 15 kg.

■ Important

▼ NOTE 2

The standards for minimum room volume are as follows.

- 1) No partition (shaded portion)

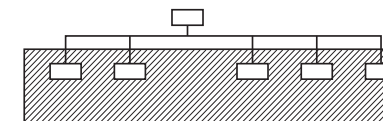

- 2) When there is an effective opening with the adjacent room for ventilation of leaking refrigerant gas (opening without a door, or an opening 0.15% or larger than the respective floor spaces at the top or bottom of the door).

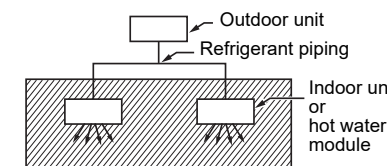

- 3) If an indoor unit (including hot water module) is installed in each partitioned room and the refrigerant piping is interconnected, the smallest room of course becomes the object. But when a mechanical ventilation is installed interlocked with a gas leakage detector in the smallest room where the density limit is exceeded, the volume of the next smallest room becomes the object.

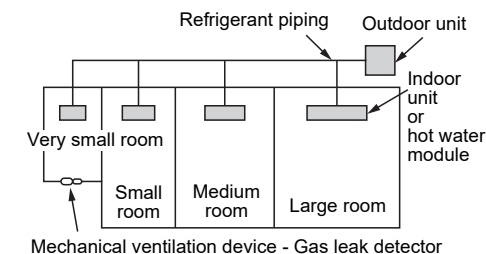

Confirmation of indoor unit setup

Prior to delivery to the customer, check the address and setup of the indoor unit (including hot water module), which has been installed in this time and fill the check sheet (Table below). Data of four units can be entered in this check sheet. Copy this sheet according to the No. of the indoor units (including hot water module). If the installed system is a group control system, use this sheet by entering each line system into each installation manual attached to the other indoor units (including hot water module).

REQUIREMENT

This check sheet is required for maintenance after installation. Fill this sheet and then pass this Installation Manual to the customers.

Indoor unit setup check sheet

Indoor unit		Indoor unit		Indoor unit		Indoor unit		
Room name	Room name	Room name	Room name	Room name	Room name	Room name	Room name	
Model	Model	Model	Model	Model	Model	Model	Model	
Check indoor unit address. (For check method, refer to Service Manual of outdoor unit.) *In case of a single system, it is unnecessary to enter the indoor address. (CODE NO.: Line [12], Indoor [13], Group [14], Central control [03])								
Line	Indoor	Group	Line	Indoor	Group	Line	Indoor	Group
Central control address			Central control address			Central control address		
Incorporation of parts sold separately		Incorporation of parts sold separately		Incorporation of parts sold separately		Incorporation of parts sold separately		
Have you incorporated the following parts sold separately? If incorporated, fill check mark [x] in each [ITEM]. (When incorporating, the setup change is necessary in some cases. For setup change method, refer to Installation Manual attached to each part sold separately.)								
<input type="checkbox"/> Others ()	<input type="checkbox"/> Others ()	<input type="checkbox"/> Others ()	<input type="checkbox"/> Others ()	<input type="checkbox"/> Others ()	<input type="checkbox"/> Others ()	<input type="checkbox"/> Others ()	<input type="checkbox"/> Others ()	
<input type="checkbox"/> Others ()	<input type="checkbox"/> Others ()	<input type="checkbox"/> Others ()	<input type="checkbox"/> Others ()	<input type="checkbox"/> Others ()	<input type="checkbox"/> Others ()	<input type="checkbox"/> Others ()	<input type="checkbox"/> Others ()	

Carrier Japan Corporation

336 TADEHARA, FUJI-SHI, SHIZUOKA-KEN 416-8521 JAPAN

**EB99841701-3
(DH91307704)**