

TOSHIBA

AIR CONDITIONER (MULTI TYPE) Installation Manual

R32 or R410A

For commercial use

Indoor Unit

Model name:

<2-way Cassette Type>

MMU-UP0071WH-E

MMU-UP0091WH-E

MMU-UP0121WH-E

MMU-UP0151WH-E

MMU-UP0181WH-E

MMU-UP0241WH-E

MMU-UP0271WH-E

MMU-UP0301WH-E

MMU-UP0361WH-E

MMU-UP0481WH-E

MMU-UP0561WH-E

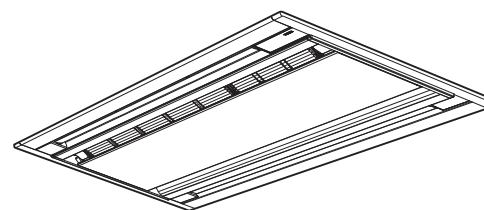

Original instruction

Please read this Installation Manual carefully before installing the Air Conditioner.

- This Manual describes the installation method of the indoor unit.
- Also read the Installation Manual that come with the outdoor unit and optional parts.

ADOPTION OF R32 OR R410A REFRIGERANT

This Air Conditioner has adopted a refrigerant HFC (R32 or R410A) which does not destroy the ozone layer. Be sure to check the refrigerant type for outdoor unit to be combined, and then install it. When combining with an outdoor unit of R32 refrigerant, it is legally necessary to connect a refrigerant leak detection system. Contact your dealer or contractor for more information on the system. To check the type of refrigerant used, refer to the outdoor unit Installation Manual.

Information

If U series models (TU2C-Link) are combined with models other than U series (TCC-Link), the wiring specifications and maximum number of connect-able indoor units will be changed. Pay attentions to their communication specifications when carrying out the installation, maintenance, or repair. For its details, refer to the “**Electrical connection**” in this Manual.

Contents

1	Precautions for safety	3
2	Accessory parts	13
3	Selection of installation place	13
4	Installation	15
5	Drain piping	19
6	Refrigerant piping	21
7	Electrical connection	22
8	Applicable controls	26
9	Test run	28
10	Maintenance	29
11	Troubleshooting	30
12	Specifications	36
13	Notice code	36

Thank you for purchasing this Toshiba air conditioner.

Please read carefully through these instructions that contain important information which complies with the "Machinery Directive 2006 / 42 / EC", and ensure that you understand them.

After completing the installation work, hand over this Installation Manual as well as the Owner's Manual provided with the outdoor unit to the user, and ask the user to keep them in a safe place for future reference.

Generic denomination: Air conditioner

Definition of qualified installer or qualified service person

The air conditioner must be installed, maintained, repaired and removed by a qualified installer or qualified service person. When any of these jobs is to be done, ask a qualified installer or qualified service person to do them.

A qualified installer or qualified service person is an agent who has the qualifications and knowledge described in the table below.

Agent	Qualifications and knowledge which the agent must have
Qualified installer (*1)	<ul style="list-style-type: none"> The qualified installer is a person who installs, maintains, relocates and removes the air conditioners made by Carrier Japan Corporation. He or she has been trained to install, maintain, relocate and remove the air conditioners made by Carrier Japan Corporation or, alternatively, he or she has been instructed in such operations by an individual or individuals who have been trained and is thus thoroughly acquainted with the knowledge related to these operations. The qualified installer who is allowed to do the electrical work involved in installation, relocation and removal has the qualifications pertaining to this electrical work as stipulated by the local laws and regulations, and he or she is a person who has been trained in matters relating to electrical work on the air conditioners made by Carrier Japan Corporation or, alternatively, he or she has been instructed in such matters by an individual or individuals who have been trained and is thus thoroughly acquainted with the knowledge related to this work. The qualified installer who is allowed to do the refrigerant handling and piping work involved in installation, relocation and removal has the qualifications pertaining to this refrigerant handling and piping work as stipulated by the local laws and regulations, and he or she is a person who has been trained in matters relating to refrigerant handling and piping work on the air conditioners made by Carrier Japan Corporation or, alternatively, he or she has been instructed in such matters by an individual or individuals who have been trained and is thus thoroughly acquainted with the knowledge related to this work. The qualified installer who is allowed to work at heights has been trained in matters relating to working at heights with the air conditioners made by Carrier Japan Corporation or, alternatively, he or she has been instructed in such matters by an individual or individuals who have been trained and is thus thoroughly acquainted with the knowledge related to this work.
Qualified service person (*1)	<ul style="list-style-type: none"> The qualified service person is a person who installs, repairs, maintains, relocates and removes the air conditioners made by Carrier Japan Corporation. He or she has been trained to install, repair, maintain, relocate and remove the air conditioners made by Carrier Japan Corporation or, alternatively, he or she has been instructed in such operations by an individual or individuals who have been trained and is thus thoroughly acquainted with the knowledge related to these operations. The qualified service person who is allowed to do the electrical work involved in installation, repair, relocation and removal has the qualifications pertaining to this electrical work as stipulated by the local laws and regulations, and he or she is a person who has been trained in matters relating to electrical work on the air conditioners made by Carrier Japan Corporation or, alternatively, he or she has been instructed in such matters by an individual or individuals who have been trained and is thus thoroughly acquainted with the knowledge related to this work. The qualified service person who is allowed to do the refrigerant handling and piping work involved in installation, repair, relocation and removal has the qualifications pertaining to this refrigerant handling and piping work as stipulated by the local laws and regulations, and he or she is a person who has been trained in matters relating to refrigerant handling and piping work on the air conditioners made by Carrier Japan Corporation or, alternatively, he or she has been instructed in such matters by an individual or individuals who have been trained and is thus thoroughly acquainted with the knowledge related to this work. The qualified service person who is allowed to work at heights has been trained in matters relating to working at heights with the air conditioners made by Carrier Japan Corporation or, alternatively, he or she has been instructed in such matters by an individual or individuals who have been trained and is thus thoroughly acquainted with the knowledge related to this work.

Definition of protective gear



When the air conditioner is to be transported, installed, maintained, repaired or removed, wear protective gloves and 'safety' work clothing.

In addition to such normal protective gear, wear the protective gear described below when undertaking the special work detailed in the table below.

Failure to wear the proper protective gear is dangerous because you will be more susceptible to injury, burns, electric shocks and other injuries.

Work undertaken	Protective gear worn
All types of work	Protective gloves 'Safety' working clothing
Electrical-related work	Clothing to provide protection from electric shock Insulating shoes Gloves to provide protection from electric shock
Work done at heights (50 cm or more)	Helmets for use in industry
Transportation of heavy objects	Shoes with additional protective toecap
Repair of outdoor unit	Gloves to provide protection for electricians

These safety cautions describe important matters concerning safety to prevent injury to users or other people and damages to property. Please read through this manual after understanding the contents below (meanings of indications), and be sure to follow the description.





Indication	Meaning of Indication
 WARNING	Text set off in this manner indicates that failure to adhere to the directions in the warning could result in serious bodily harm (*1) or loss of life if the product is handled improperly.
 CAUTION	Text set off in this manner indicates that failure to adhere to the directions in the caution could result in slight injury (*2) or damage (*3) to property if the product is handled improperly.

*1: Serious bodily harm indicates loss of eyesight, injury, burns, electric shock, bone fracture, poisoning, and other injuries which leave aftereffect and require hospitalization or long-term treatment as an outpatient.

*2: Slight injury indicates injury, burns, electric shock, and other injuries which do not require hospitalization or long-term treatment as an outpatient.

*3: Damage to property indicates damage extending to buildings, household effects, domestic livestock, and pets.

■ Warning indications on the air conditioner unit

Warning indication		Description
	<p>WARNING</p> <p>ELECTRICAL SHOCK HAZARD Disconnect all remote electric power supplies before servicing.</p>	<p>WARNING</p> <p>ELECTRICAL SHOCK HAZARD Disconnect all remote electric power supplies before servicing.</p>
	<p>WARNING</p> <p>Moving parts. Do not operate unit with grille removed. Stop the unit before the servicing.</p>	<p>WARNING</p> <p>Moving parts. Do not operate unit with grille removed. Stop the unit before the servicing.</p>
	<p>CAUTION</p> <p>High temperature parts. You might get burned when removing this panel.</p>	<p>CAUTION</p> <p>High temperature parts. You might get burned when removing this panel.</p>
	<p>CAUTION</p> <p>Do not touch the aluminum fins of the unit. Doing so may result in injury.</p>	<p>CAUTION</p> <p>Do not touch the aluminum fins of the unit. Doing so may result in injury.</p>
	<p>CAUTION</p> <p>BURST HAZARD Open the service valves before the operation, otherwise there might be the burst.</p>	<p>CAUTION</p> <p>BURST HAZARD Open the service valves before the operation, otherwise there might be the burst.</p>

1 Precautions for safety

The manufacturer shall not assume any liability for the damage caused by not observing the description of this manual.

When connecting to an outdoor unit that uses R32 refrigerant, be sure to read the warnings and cautions in “Precautions for using R32 refrigerant”.

WARNING

General

- Before starting to install the air conditioner, read through the Installation Manual carefully, and follow its instructions to install the air conditioner.
- Only a Qualified installer (*1) or Qualified service person (*1) is allowed to do installation work. Inappropriate installation may result in water leakage, electric shock or fire.
- Do not use any refrigerant different from the one specified for complement or replacement. Otherwise, abnormally high pressure may be generated in the refrigeration cycle, which may result in a failure or explosion of the product or an injury to your body.
- Before opening the intake grille of the indoor unit or service panel of the outdoor unit, set the circuit breaker to the OFF position. Failure to set the circuit breaker to the OFF position may result in electric shocks through contact with the interior parts. Only a Qualified installer (*1) or Qualified service person (*1) is allowed to remove the intake grille of the indoor unit or service panel of the outdoor unit and do the work required.
- Before carrying out the installation, maintenance, repair or removal work, set the circuit breaker to the OFF position. Otherwise, electric shocks may result.
- Place a “Work in progress” sign near the circuit breaker while the installation, maintenance, repair or removal work is being carried out. There is a danger of electric shocks if the circuit breaker is set to ON by mistake.
- Only a Qualified installer (*1) or Qualified service person (*1) is allowed to undertake work at heights using a stand of 50 cm or more or to remove the intake grille of the indoor unit to undertake work.
- Wear protective gloves and safety work clothing during installation, servicing and removal.

- Do not touch the aluminum fin of the unit. You may injure yourself if you do so. If the fin must be touched for some reason, first put on protective gloves and safety work clothing, and then proceed.
- Do not climb onto or place objects on top of the outdoor unit. You may fall or the objects may fall off of the outdoor unit and result in injury.
- When work is performed at heights, use a ladder which complies with the ISO 14122 standard, and follow the procedure in the ladder's instructions. Also wear a helmet for use in industry as protective gear to undertake the work.
- Before cleaning the filter or other parts of the indoor unit, set the circuit breaker to OFF without fail, and place a "Work in progress" sign near the circuit breaker before proceeding with the work.
- Before working at heights, put a sign in place so that no-one will approach the work location, before proceeding with the work. Parts and other objects may fall from above, possibly injuring a person below. While carrying out the work, wear a helmet for protection from falling objects.
- The refrigerant used by this air conditioner is the R32 or R410A.
- The air conditioner must be transported in stable condition. If any part of the product is broken, contact the dealer.
- When the air conditioner must be transported by hand, carry it by four or more people.
- Do not move or repair any unit by yourself. There is high voltage inside the unit. You may get electric shock when removing the cover and main unit.
- This appliance is intended to be used by expert or trained users in shops, in light industry, or for commercial use by lay persons.

Selection of installation location

- When the air conditioner is installed in a small room, provide appropriate measures to ensure that the concentration of refrigerant leakage occur in the room does not exceed the critical level.
- Do not install in a location where flammable gas leaks are possible. If the gas leak and accumulate around the unit, it may ignite and cause a fire.
- To transport the air conditioner, wear shoes with additional protective toe caps.
- To transport the air conditioner, do not take hold of the bands around the packing carton. You may injure yourself if the bands should break.

- Install the indoor unit at least 2.5 m above the floor level since otherwise the users may injure themselves or receive electric shocks if they poke their fingers or other objects into the indoor unit while the air conditioner is running.
- Do not place any combustion appliance in a place where it is directly exposed to the wind of air conditioner, otherwise it may cause imperfect combustion.

Installation

- When the indoor unit is to be suspended, the designated hanging bolts (M10 or W3/8) and nuts (M10 or W3/8) must be used.
- Install the air conditioner securely in a location where the base can sustain the weight adequately. If the strength is not enough, the unit may fall down resulting in injury.
- Follow the instructions in the Installation Manual to install the air conditioner. Failure to follow these instructions may cause the product to fall down or topple over or give rise to noise, vibration, water leakage or other trouble.
- Carry out the specified installation work to guard against the possibility of earthquake. If the air conditioner is not installed appropriately, a unit may topple over or fall down, causing an accident.
- If refrigerant gas has leaked during the installation work, ventilate the room immediately. If the leaked refrigerant gas comes in contact with fire, noxious gas may generate.
- Use forklift to carry in the air conditioner units and use winch or hoist at installation of them.

Refrigerant piping

- Install the refrigerant pipe securely during the installation work before operating the air conditioner. If the compressor is operated with the valve open and without refrigerant pipe, the compressor sucks air and the refrigeration cycles is over pressurized, which may cause a injury.
- Tighten the flare nut with a torque wrench in the specified manner. Excessive tighten of the flare nut may cause a crack in the flare nut after a long period, which may result in refrigerant leakage.
- After the installation work, confirm that refrigerant gas does not leak. If refrigerant gas leaks into the room and flows near a fire source, such as a cooking range, noxious gas may be generated.

- When the air conditioner has been installed or relocated, follow the instructions in the Installation Manual and purge the air completely so that no gases other than the refrigerant will be mixed in the refrigerating cycle. Failure to purge the air completely may cause the air conditioner to malfunction.
- Nitrogen gas must be used for the airtight test.
- The charge hose must be connected tightly and in a proper manner.
- If refrigerant gas has leaked during the installation work, ventilate the room immediately. If the leaked refrigerant gas comes in contact with fire, noxious gas may be generated.

Electrical wiring

- Only a Qualified installer (*1) or Qualified service person (*1) is allowed to carry out the electrical work of the air conditioner. Under no circumstances must this work be done by an unqualified individual since failure to carry out the work properly may result in electric shocks and/or electrical leaks.
- To connect the electrical wires, repair the electrical parts or undertake other electrical jobs, wear gloves to provide protection for electricians, insulating shoes and clothing to provide protection from electric shocks. Failure to wear this protective gear may result in electric shocks.
- Use wiring that meets the specifications in the Installation Manual and the stipulations in the local regulations and laws. Use of wiring which does not meet the specifications may give rise to electric shocks, electrical leakage, smoking and/or a fire.
- Be sure to connect earth wire. (Grounding work)
Incomplete grounding causes an electric shock.
- Do not connect earth wires to gas pipes, water pipes, and lightning conductor or telephone earth wires.
- After completing the repair or relocation work, check that the earth wires are connected properly.
- Install a circuit breaker that meets the specifications in the Installation Manual and the stipulations in the local regulations and laws.
- Install the circuit breaker where it can be easily accessed by the agent.
- When installing the circuit breaker outdoors, install one which is designed to be used outdoors.
- Under no circumstances the power wire must not be extended. Connection trouble in the places where the wire is extended may give rise to smoking and/or a fire.

- Electrical wiring work shall be conducted according to law and regulation in the community and Installation Manual.
Failure to do so may result in electrocution or short circuit.

Test run

- Before operating the air conditioner after having completed the work, check that the electrical control box cover of the indoor unit and service panel of the outdoor unit are closed, and set the circuit breaker to the ON position. You may receive an electric shock if the power is turned on without first conducting these checks.
- If there is any kind of trouble (such as check code display has appeared, smell of burning, abnormal sounds, the air conditioner fails to cool or heat or water is leaking) has occurred in the air conditioner, do not touch the air conditioner yourself but set the circuit breaker to the OFF position, and contact a Qualified service person (*1). Take steps to ensure that the power will not be turned on (by marking "out of service" near the circuit breaker, for instance) until qualified service person arrives. Continuing to use the air conditioner in the trouble status may cause mechanical problems to escalate or result in electric shocks or other trouble.
- After the work has finished, use an insulation tester set (500 V Megger) to check the resistance is 1 MΩ or more between the charge section and the non-charge metal section (Earth section). If the resistance value is low, a disaster such as a leak or electric shock is caused at user's side.
- Upon completion of the installation work, check for refrigerant leaks and check the insulation resistance and water drainage. Then conduct a test run to check that the air conditioner is operating properly.

Explanations given to user

- Upon completion of the installation work, tell the user where the circuit breaker is located. If the user does not know where the circuit breaker is, he or she will not be able to turn it off in the event that trouble has occurred in the air conditioner.
- After the installation work, follow the Owner's Manual to explain to the customer how to use and maintain the unit.

Relocation

- Only a Qualified installer (*1) or Qualified service person (*1) is allowed to relocate the air conditioner. It is dangerous for the air conditioner to be relocated by an unqualified individual since a fire, electric shocks, injury, water leakage, noise and/or vibration may result.
- When carrying out the pump-down work shut down the compressor before disconnecting the refrigerant pipe. Disconnecting the refrigerant pipe with the service valve left open and the compressor still operating will cause air or other gas to be sucked in, raising the pressure inside the refrigeration cycle to an abnormally high level, and possibly resulting in rupture, injury or other trouble.

(*1) Refer to the "Definition of qualified installer or qualified service person".

CAUTION

This Air Conditioner has adopted a refrigerant HFC (R32 or R410A) which does not destroy the ozone layer.

- As the R32 or R410A refrigerant is easily affected by impurities such as moisture, oxidized film, oil, etc., due to the high pressure, be careful not to allow the moisture, dirt, existing refrigerant, refrigerating machine oil, etc., to get mixed up in the refrigeration cycle during the installation work.
- A special tool for the R32 or R410A refrigerant is required for installation.
- Use a new and clean piping materials for the connecting pipe so that moisture and dirt are not mixed together during the installation work.

To Disconnect the Appliance from Main Power Supply.

- This appliance must be connected to the main power supply by means of a switch with a contact separation of at least 3 mm.
-





Precautions for using R32 refrigerant

The basic installation work procedures are the same as conventional refrigerant (R410A, R22) models.

However, Please read through this manual after understanding the contents below;

These safety cautions describe important matters concerning safety to prevent injury to users or other people and damages to property. Please read through this manual after understanding the contents below (meanings of indications), and be sure to follow the description;

Meanings of symbols displayed on the unit

	<p>WARNING (Risk of fire)</p>	<p>This mark is for R32 refrigerant only. Refrigerant type is written on nameplate of outdoor unit. In case that refrigerant type is R32, this unit uses a flammable refrigerant. If refrigerant leaks and comes in contact with fire or heating part, it will create harmful gas and there is risk of fire.</p>
	<p>Read the OWNER'S MANUAL carefully before operation.</p>	
	<p>Service personnel are required to carefully read the OWNER'S MANUAL and INSTALLATION MANUAL before operation.</p>	
	<p>Further information is available in the OWNER'S MANUAL, INSTALLATION MANUAL, and the like.</p>	

WARNING

- Models that use refrigerant R32 and R410A have a different charging port thread diameter to prevent erroneous charging with refrigerant R22 and for safety.
- Do not use means to accelerate the defrosting process or to clean, other than those recommended by the manufacturer.
- The appliance shall be stored in a room without continuously operating ignition sources. (For example: open flames, an operating gas appliance or an operating electric heater.)
- Do not pierce or burn.
- Be aware that refrigerants may not contain an odor.
- The manufacturer may provide other suitable examples or may provide additional information about the refrigerant odor.

CAUTION

When a flammable refrigerant is used, all appliances shall be charged with refrigerant at the manufacturing location or charged on site as recommended by the manufacturer.

A part of an appliance that is charged on site, which requires brazing or welding in the installation shall not be shipped with a flammable refrigerant charge. Joints made in the installation between parts of the refrigerating system, with at least one part charged, shall be made in accordance with the following.

- A brazed, welded, or mechanical connection shall be made before opening the valves to permit refrigerant to flow between the refrigerating system parts. A vacuum valve shall be provided to evacuate the interconnecting pipe and/or any uncharged refrigerating system part.
- Mechanical connectors used indoors shall comply with ISO 14903. When mechanical connectors are reused indoors, sealing parts shall be renewed. When flared joints are reused indoors, the flare part shall be re-fabricated.
- Refrigerant tubing shall be protected or enclosed to avoid damage. Flexible refrigerant connectors (such as connecting lines between the indoor and outdoor unit) that may be displaced during normal operations shall be protected against mechanical damage.

General (Installation space / area)

- The installation of pipe-work shall be kept to a minimum.
- Pipe-work shall be protected from physical damage.
- The compliance with national gas regulations shall be observed.
- The mechanical connections shall be accessible for maintenance purposes.
- In cases that require mechanical ventilation, ventilation openings shall be kept clear of obstruction.
- When disposing of the product is used, be based on national regulations with properly processed.
- The servicing shall be performed only as recommended by the manufacturer.
- Where the appliance using flammable refrigerants is installed, Be aware that;
 - The appliance shall be stored in a well-ventilated area where the room size corresponds to the room area as specified for operation.
 - The appliance shall be stored in a room without continuously operating open flames (for example an operating gas appliance) and ignition sources (for example an operating electric heater).
 - The appliance shall be stored so as to prevent mechanical damage from occurring.
- Equipment piping in the occupied space shall be installed in such a way to protect against accidental damage in operation and service.
- Precautions shall be taken to avoid excessive vibration or pulsation to refrigerating piping.
- Protection devices, piping and fittings shall be protected as far as possible against adverse environmental effects, for example, the danger of water collecting and freezing in relief pipes or the accumulation of dirt and debris.
- Provision shall be made for expansion and contraction of long runs of piping.
- Piping in refrigerating systems shall be so designed and installed to minimize the likelihood hydraulic shock damaging the system.
- Solenoid valves shall be correctly positioned in the piping to avoid hydraulic shock.
- Solenoid valves shall not block in liquid refrigerant unless adequate relief is provided to the refrigerant system low pressure side.
- Steel pipes and components shall be protected against corrosion with a rustproof coating before applying any insulation.
- Flexible pipe elements shall be protected against mechanical damage, excessive stress by torsion, or other forces. They should be checked for mechanical damage annually.

- The indoor equipment and pipes shall be securely mounted and guarded such that accidental rupture of equipment cannot occur from such events as moving furniture or reconstruction activities.
- Where safety shut off valves are specified, the minimum room area may be determined based on the maximum amount of refrigerant that can be leaked as determined in Installation Manual.
- Where safety shut off valves are specified, the location of the valve in the refrigerating system relative to the occupied spaces shall be as described in Installation Manual.
- Field-made refrigerant joints indoors shall be tightness tested. The test method shall have a sensitivity of 5 grams per year of refrigerant or better under a pressure of at least 0.25 times the maximum allowable pressure. No leak shall be detected.
- The total refrigerant charge in the system cannot exceed the requirements for minimum floor area of the smallest room that is served. For minimum floor area requirements for indoor units, see the Installation and Owner's Manual of the outdoor unit.
- When connecting to an outdoor unit of R32 refrigerant and using a leak detector, always turn on the power of the indoor unit after installation except during service in order to detect refrigerant leakage and take safety measures.

Unventilated area

- The appliance shall be stored so as to prevent mechanical damage from occurring.

Information on servicing

1. Check to the area

- Prior to beginning work on systems containing flammable refrigerants, safety checks are necessary to ensure that the risk of ignition is minimized. For repair to the refrigerating system, the precautions in item 2 to 6 shall be complied with prior to conducting work on the system.

2. Work procedure

- Work shall be undertaken under a controlled procedure so as to minimize the risk of a flammable gas or vapour being present while the work is being performed.
- When connecting to an outdoor unit of R32 refrigerant and using a leak detector, the fan may automatically operate even if the air conditioner is stopped when a refrigerant leak is detected. Be careful not to get injured by the fan.

3. General work area

- All maintenance staff and others working in the local area shall be instructed on the nature of work being carried out.
- Work in confined spaces shall be avoided.
- The area around the workspace shall be sectioned off.
- Ensure that the conditions within the area have been made safe by control of flammable material.

4. Checking for presence of refrigerant

- The area shall be checked with an appropriate refrigerant detector prior to and during work, to ensure the technician is aware of potentially flammable atmospheres.
- Ensure that the leak detection equipment being used is suitable for use with all applicable refrigerants, i.e. non sparking, adequately sealed or intrinsically safe.

5. Presence of fire extinguisher

- If any hot work is to be conducted on the refrigeration equipment or any associated parts, appropriate fire extinguishing equipment shall be available on hand.
- Have a dry powder or CO₂ fire extinguisher adjacent to the charging area.

6. No ignition sources

- No person carrying out work in relation to a refrigeration system which involves exposing any pipe work shall use any sources of ignition in such a manner that it may lead to the risk of fire or explosion.
- All possible ignition sources including cigarette smoking, should be kept sufficiently far away from the site of installation, repairing, removing and disposal, during which refrigerant can possibly be released to the surrounding space.
- Prior to work taking place, the area around the equipment is to be surveyed to make sure that there are no flammable hazards or ignition risks. "No Smoking" signs shall be displayed.

7. Ventilated area

- Ensure that the area is in the open or that it is adequately ventilated before breaking into the system or conducting any hot work.
- A degree of ventilation shall continue during the period that the work is carried out.
- The ventilation should safely disperse any released refrigerant and preferably expel it externally into the atmosphere.

8. Checks to the refrigeration equipment

- Where electrical components are being changed, installer shall be fit for the purpose and to the correct specification.
- At all times the manufacturer's maintenance and service guidelines shall be followed. If in doubt consult the manufacturer's technical department for assistance.
- The following checks shall be applied to installations using flammable refrigerants.
 - The charge size is in accordance with the room size within which the refrigerant containing parts are installed.
 - The ventilation machinery and outlets are operating adequately and are not obstructed.
 - If an indirect refrigerating circuit is being used, the secondary circuit shall be checked for the presence of refrigerant.
 - Marking to the equipment continues to be visible and legible. Markings and signs that are illegible shall be corrected.
 - Refrigeration pipe or components are installed in a position where they are unlikely to be exposed to any substance which may corrode refrigerant containing components, unless the components are constructed of materials which are inherently resistant to being corroded or are suitably protected against being so corroded.

9. Checks to electrical devices

- Repair and maintenance to electrical components shall include initial safety checks and component inspection procedures.
- If a fault exists that could compromise safety, then no electrical supply shall be connected to the circuit until it is satisfactorily dealt with.
- If the fault cannot be corrected immediately but it is necessary to continue operation, an adequate temporary solution shall be used. This shall be reported to the owner of the equipment so all parties are advised.
- Initial safety checks shall include;
 - That capacitors are discharged to avoid possibility of sparking.
 - That there no live electrical components and wiring are exposed while charging, recovering or purging the system.
 - That there is continuity of earth bonding.

10. Repairs to sealed components

- During repairs to sealed components, all electrical supplies shall be disconnected from the equipment being worked upon prior to any removal of sealed covers, etc.

- If it is absolutely necessary to have an electrical supply to equipment during servicing, then a permanently operating form of leak detection shall be located at the most critical point to warn of a potentially hazardous situation.
- Particular attention shall be paid to the following to ensure that by working on electrical components, the casing is not altered in such a way that the level of protection is affected.
- This shall include damage to cables, excessive number of connections, terminals not made to original specification, damage to seals, incorrect fitting of glands, etc.
- Ensure that apparatus is mounted securely.
- Ensure that seals or sealing materials have not degraded to the point that they no longer serve the purpose of preventing the ingress of flammable atmospheres.
- Replacement parts shall be in accordance with the manufacturer's specifications.

NOTE

The use of silicon sealant may inhibit the effectiveness of some types of leak detection equipment. Intrinsically safe components do not have to be isolated prior to working on them.

11.Repair to intrinsically safe components

- Do not apply any permanent inductive or capacitance loads to the circuit without ensuring that this will not exceed the permissible voltage and current permitted for the equipment in use.
- Intrinsically safe components are the only types that can be worked on while live in the presence of a flammable atmosphere.
- The test apparatus shall be at the correct rating.
- Replace components only with parts specified by the manufacturer.
- Other parts may result in the ignition of refrigerant in the atmosphere from a leak.

12.Cabling

- Check that cabling will not be subject to wear, corrosion, excessive pressure, vibration, sharp edges or any other adverse environmental effects.
- Check shall also take into account the effects of aging or continual vibration from sources such as compressors or fans.

13.Detection of flammable refrigerants

- Under no circumstances shall potential sources of ignition be used in the searching for or detection of refrigerant leaks.

- A halide torch (or any other detector using a naked flame) shall not be used.
- Electronic leak detectors may be used to detect refrigerant leaks but, in the case of flammable refrigerants, the sensitivity may not be adequate, or may need re-calibration. (Detection equipment shall be calibrated in a refrigerant-free area.)
- Ensure that the detector is not a potential source of ignition and is suitable for the refrigerant used.
- Leak detection equipment shall be set at a percentage of the LFL of the refrigerant and shall be calibrated to the refrigerant employed, and the appropriate percentage of gas (25% maximum) is confirmed.
- Leak detection fluids are also suitable for use with most refrigerants but the use of detergents containing chlorine shall be avoided as the chlorine may react with the refrigerant and corrode containing chlorine.
- If a leak is suspected, all naked flames shall be removed/ extinguished.
- If a leakage of refrigerant is found which requires brazing, all of the refrigerant shall be recovered from the system, or isolated (by means of shut off valves) in a part of the system remote from the leak.

14.Leak detection methods

- Electronic leak detectors shall be used to detect flammable refrigerants leak, but the sensitivity may not be adequate, or may need re-calibration. (Detection equipment shall be calibrated in a refrigerant-free area.)
- Ensure that the detector is not a potential source of ignition and is suitable for the refrigerant used.
- Leak detection equipment shall be set at a percentage of the LFL of the refrigerant and shall be calibrated to the refrigerant employed and the appropriate percentage of gas (25% maximum) is confirmed.
- Leak detection fluids are suitable for use with most refrigerants but the use of detergents containing chlorine shall be avoided as the chlorine may react with the refrigerant and corrode the copper pipe-work.
- If a leak is suspected, all naked flames shall be removed / extinguished.
- If a leakage of refrigerant is found which requires brazing, all of the refrigerant shall be recovered from the system, or isolated (by means of shut off valves) in a part of the system remote from the leak.
- Oxygen free nitrogen (OFN) shall then be purged through the system both before and during the brazing process.

15. Removal and evacuation

- When breaking into the refrigerant circuit to make repairs or for any other purpose, Conventional procedures shall be used. However, it is important that best practice is followed since flammability is a consideration.

The following procedure shall be adhered to:

- remove refrigerant;
- purge the circuit with inert gas;
- evacuate;
- purge again with inert gas;
- open the circuit by cutting or brazing;
- The refrigerant charge shall be recovered into the correct recovery cylinders.
- The system shall be "Flushed" with OFN to render the unit safe.
- This process may need to be repeated several times.
- Compressed air or oxygen shall not be used for purging refrigerant systems.
- Flushing shall be achieved by breaking the vacuum in the system with OFN and continuing to fill until the working pressure is achieved, then venting to atmosphere, and finally pulling down to a vacuum.
- This process shall be repeated until no refrigerant is within the system.
- When the final OFN charge is used, the system shall be vented down to atmospheric pressure to enable work to take place.
- This operation is absolutely vital if brazing operations on the pipe-work are to take place.
- Ensure that the outlet for the vacuum pump is not close to any ignition sources and that ventilation available.

16. Charging procedures

- In addition to conventional charging procedures, the following requirements shall be followed.
 - Ensure that contamination of different refrigerants does not occur when using charging equipment.
 - Hoses or lines shall be as short as possible to minimize the amount of refrigerant contained in them.
 - Cylinders shall be kept upright.
 - Ensure that the refrigeration system is earthed prior to charging the system with refrigerant.
 - Label the system when charging is complete (if not already).
 - Extreme care shall be taken not to overfill the refrigeration system.

- Prior to recharging the system, it shall be pressure-tested with the appropriate purging gas.
- The system shall be leak tested on completion of charging but prior to commissioning.
- A follow up leak test shall be carried out prior to leaving the site.

17. Decommissioning

- Before carrying out this procedure, it is essential that the technician is completely familiar with the equipment and all its details.
- It is recommended good practice that all refrigerants are recovered safely.
- Prior to the task being carried out, an oil and refrigerant sample shall be taken in case analysis is required to reuse of reclaimed refrigerant.
- It is essential that electrical power is available before the task is commenced.
 - a) Become familiar with the equipment and its operation.
 - b) Isolate system electrically.
 - c) Before attempting the procedure ensure that:
 - Mechanical handling equipment is available, if required, for handling refrigerant cylinders;
 - All personal protective equipment is available and being used correctly;
 - The recovery process is supervised at all times by a competent person;
 - Recovery equipment and cylinders conform to the appropriate standards.
 - d) Pump down refrigerant system, if possible.
 - e) If a vacuum is not possible, make a manifold so that refrigerant can be removed from various parts of the system.
 - f) Make sure that cylinder is situated on the scales before recovery takes place.
 - g) Start the recovery machine and operate in accordance with manufacturer's instructions.
 - h) Do not overfill cylinders. (No more than 80% volume liquid charge.)
 - i) Do not exceed the maximum working pressure of the cylinder, even temporarily.
 - j) When the cylinders have been filled correctly and the process completed, make sure that the cylinders and the equipment are removed from site promptly and all isolation valves on the equipment are closed off.
 - k) Recovered refrigerant shall not be charged into another refrigeration system unless it has been cleaned and checked.

18. Labelling









- Equipment shall be labelled stating that it has been decommissioned and emptied of refrigerant.
- The label shall be dated and signed.
- Ensure that there are labels on the equipment stating the equipment contains flammable refrigerant.

19. Recovery

- When removing refrigerant from a system, either for servicing or decommissioning, it is recommended good practice that all refrigerants are removed safely.
- When transferring refrigerant into cylinders, ensure that only appropriate refrigerant recovery cylinders are employed.
- Ensure that the correct number of cylinders for holding the total system charge are available.
- All cylinders to be used are designated for the recovered refrigerant and labelled for that refrigerant (i.e. special cylinders for the recovery of refrigerant).
- Cylinders shall be complete with pressure-relief valve and associated shut-off valves in good working order.
- Empty recovery cylinders are evacuated and, if possible, cooled before recovery occurs.
- The recovery equipment shall be in good working order with a set of instructions concerning the equipment that is at hand and shall be suitable for the recovery of all appropriated refrigerants.
- In addition, a set of calibrated weighing scales shall be available and in good working order.
- Hoses shall be complete with leak-free disconnect couplings and in good condition.
- Before using the recovery machine, check that it is in satisfactory working order, has been properly maintained and that any associated electrical components are sealed to prevent ignition in the event of a refrigerant release.
- Consult manufacturer if in doubt.
- The recovered refrigerant shall be returned to the refrigerant supplier in the correct recovery cylinder, and the relevant waste transfer note arranged.
- Do not mix refrigerants in recovery units and especially not in cylinders.
- If compressors or compressor oils are to be removed, ensure that they have been evacuated to an acceptable level to make certain that flammable refrigerant does not remain within the lubricant.

-
- The evacuation process shall be carried out prior to returning the compressor to the suppliers.
 - Only electric heating to the compressor body shall be employed to accelerate this process.
 - When oil is drained from a system, it shall be carried out safely.
-

2 Accessory parts

Part name	Q'ty	Shape	Usage
Installation Manual	1	This manual	Be sure to hand over to customers (For other languages that do not appear in this Installation Manual, please refer to the enclosed CD-ROM.)
Installation pattern	1	—	For confirmation of ceiling opening and indoor unit position
CD-ROM	1	—	Installation Manual
Installation gauge	1		For positioning of ceiling position (Incorporated with the installation pattern)
Pattern fastening screw	4		For attaching the pattern (M5 x l16)
Banding band	4		For anchoring the insulated pipes
Heat insulation pipe	2		For heat insulation of pipe connecting section
Washer	8		For hanging-up of unit (M10 x Dia.34)
Hose band	1		For connecting drain pipe
Flexible hose	1		For adjusting center of drain pipe
Heat insulation	1		For heat insulation of drain connecting section
Heat insulation	1		For sealing of wire connecting port (with slit)

■ Separate sold parts

The Ceiling panel and remote controller are sold separately. For the installation of these products, follow the Installation Manuals supplied with them.

3 Selection of installation place

⚠ WARNING

- **Install the air conditioner securely in a location where the base can sustain the weight adequately.**
If the strength is not enough, the unit may fall down resulting in injury.
- **Install the air conditioner at a height 2.5 m or more from the floor.**
If you insert your hands or others directly into the unit while the air conditioner operates, it is dangerous because you may contact with revolving fan or active electricity.

⚠ CAUTION

- **Do not install in a location where flammable gas may leaks are possible.**
If the gas leak and accumulate around the unit, it may ignite and cause a fire.
- **When an outdoor unit using R32 refrigerant is combined with indoor unit, be attention to the floor area in the room to be installed.**
Indoor units cannot be installed in rooms with a floor area less than the minimum floor area. For details, follow the Installation Manual of the outdoor unit.

Upon approval of the customer, install the air conditioner in a place that satisfies the following conditions.

- Place where the unit can be installed horizontally.
- Place where a sufficient servicing space can be ensured for safety maintenance and check.
- Place where drained water will not cause any problem.

Avoid installing in the following places.

- Place exposed to air with high salt content (seaside area), or place exposed to large quantities of sulfide-containing gas (hot spring).
(The unit should be used in these places, special protective measures are needed.)
- A kitchen in restaurant or places around machines and equipment in a factory, where a lot of oils are used.
(Oil adhering to the heat exchanger and the resin parts in the indoor unit may lower the unit performance, splash water drops, or produce mist and may cause the resin parts to be deformed or damaged.)
- Places where iron or other metal dust is present. If iron or other metal dust adheres to or collects on the interior of the air conditioner, it may spontaneously combusted and start a fire.
- Place where organic solvent is used nearby.
- Place close to a machine generating high frequency.
- Place where the discharged air blows directly into the window of the neighbor house. (Outdoor unit)
- Place where noise of the outdoor unit is easily transmitted.
(When the outdoor unit is installed on the boundary with the neighbor, pay due attention to the level of noise.)
- Place with poor ventilation. (Before air duct work, check whether value of fan speed, static pressure and duct resistance are correct.)
- Do not use the air conditioner for special purposes such as preserving food, precision instruments, or art objects, or where breeding animals or growing plants are kept. (This may degrade the quality of preserved materials.)
- Place where any of high-frequency appliances (including inverter devices, private power generators, medical equipment, and communication equipment) and inverter-type fluorescent light is installed.
(A malfunction of the air conditioner, abnormal control, or problems due to noise to such appliances / equipment may occur.)
- When the wireless remote controller is used in a room equipped with an inverter-type fluorescent light or at a place exposed to direct sunlight, signals from the remote controller may not be received correctly.
- Place where organic solvent is used.
- Place near a door or window exposed to humid outside air (Dew drop may form.).
- Place where special spray is used frequently.

■ Installation space

Provide the space required for installing and servicing the indoor unit.

Provide a clearance of at least 5 mm between the top panel of the indoor unit and ceiling.

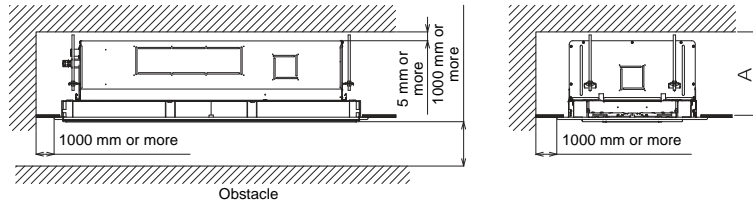

▼ Installation space

Model: MMU-	Height: A
UP007 to UP015	300 mm or more
UP018 to UP056	350 mm or more

■ Ceiling height

It is hard for the warm air to reach the floor level if the ceiling height exceeds the standard dimension (set at the time of shipment) in the table below. Therefore, the high-ceiling setting must be selected.

For details on how to select this setting, refer to the section "Installing indoor unit on high ceiling" in Applicable controls of this manual.

▼ Height list of ceiling possible to be installed

(Unit: m)

Model: MMU-	UP007 to UP030	UP036 to UP056	Set data
Standard (At shipment)	2.7	2.7	0000
High ceiling (1)	3.2	3.0	0001
High ceiling (3)	3.8	3.5	0003

REQUIREMENT

- A high-ceiling installation can only be used for models UP007 to UP012 when the ratio of total connection capacity of the indoor unit to the outdoor unit capacity is 100% or less. Do not use this kind of installation if this capacity is over 100%.
- It is possible to change how long the filter sign (signaling that it is time to clean the filter) is to stay lighted on the remote controller in accordance with the installation conditions.
- It is also possible to raise the detection temperature for the heating if it is hard for the air conditioner to heat up the environment satisfactorily due to a factor such as the location where the indoor unit is installed or the structure of the room.
- For details on the setting, refer to the section "Installing indoor unit on high ceiling" and "To secure better effect of heating" in Applicable controls of this manual.

■ Installation of wireless remote controller (Sold separately)

The signal receiving unit of indoor unit can receive a signal by distance within approx. 7 m. Based upon it, determine a place where the remote controller is operated and the installation place.

- Operate the remote controller, confirm that the indoor unit receives a signal surely, and then install it.
- Keep 1 m or more from the devices such as television. (Disturbance of image or noise may generate.)
- To prevent a malfunction and reception failure of the remote controller, select a place where it is not influenced by a fluorescent light, equipment (Electronic whiteboard etc.) emitting infrared rays, or direct sunlight.
- Switching the setting (A-B selection) of the wireless remote controllers and the signal receiving unit enables two indoor units installed in a room to be respectively operated using two wireless remote controllers.

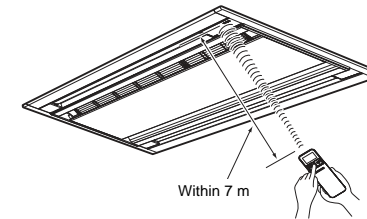

4 Installation

CAUTION

- Strictly comply with the following rules to prevent damage of the indoor units and human injury.
- Do not put any heavy article on the indoor unit. (Even units are packaged)
- Carry in the indoor unit as it is packaged if possible. If carrying in the indoor unit unpacked by necessity, be sure to use buffering cloth, etc. to not damage the unit.
- To move the indoor unit, hold the hooking metals (4 positions) only.
Do not apply force to the other parts (refrigerant pipe, drain pan, foamed parts, or resin parts, etc.).
- Carry the package by two or more persons, and do not bundle it with plastic band at positions other than specified.

External view

UP007 to UP015

(Unit: mm)

Refrigerant pipe connecting port

Model: MMU-	Gas side: A
UP007 to UP012	9.5
UP015	12.7

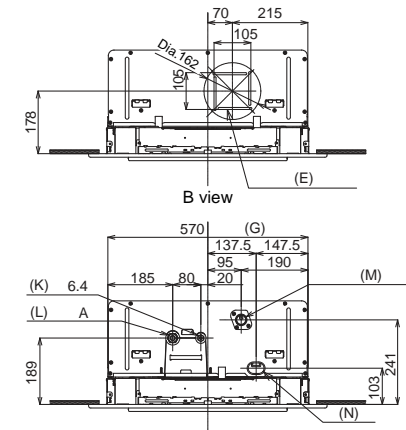
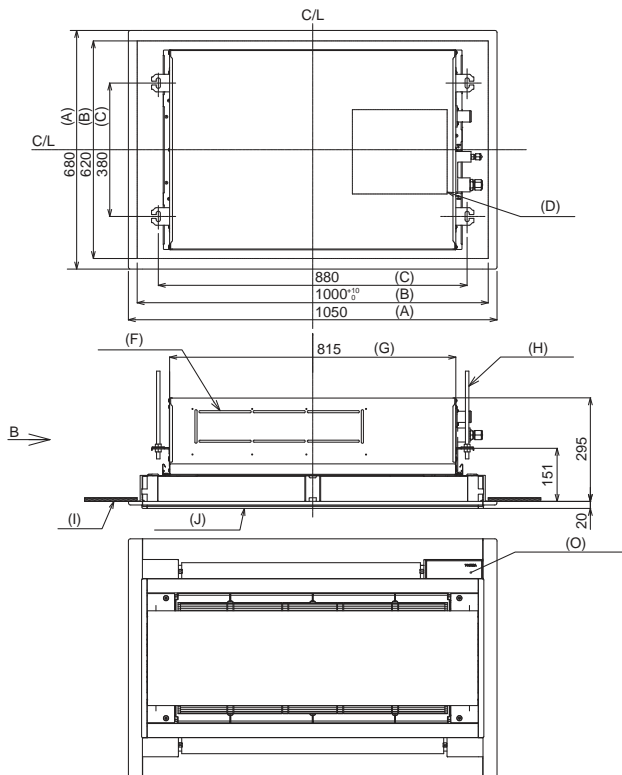

(A)	Panel external dimension	(I)	Ceiling bottom surface
(B)	Ceiling opening dimension	(J)	Ceiling panel (Sold separately)
(C)	Hanging bolt pitch	(K)	Refrigerant pipe connecting port (Liquid)
(D)	Electrical control box	(L)	Refrigerant pipe connecting port (Gas)
(E)	Knockout square hole for auxiliary fresh air flange For Dia.150 (Sold separately)	(M)	Drain pipe connecting port (Be absolutely sure to use the flexible hose provided for the connection here.)
(F)	Knockout hole	(N)	Take-in port of wires
(G)	Unit external dimension	(O)	Wireless signal receiving unit mounting area (Sold separately)
(H)	Hanging bolt M10 or W3/8 (Locally procured)		

UP018 to UP030

(Unit: mm)

▼ Refrigerant pipe connecting port

Model: MMU-	Liquid side: A	Gas side: B
UP018	6.4	12.7
UP024 to UP030	9.5	15.9

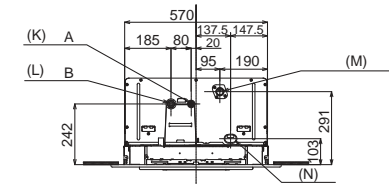
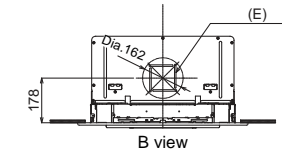
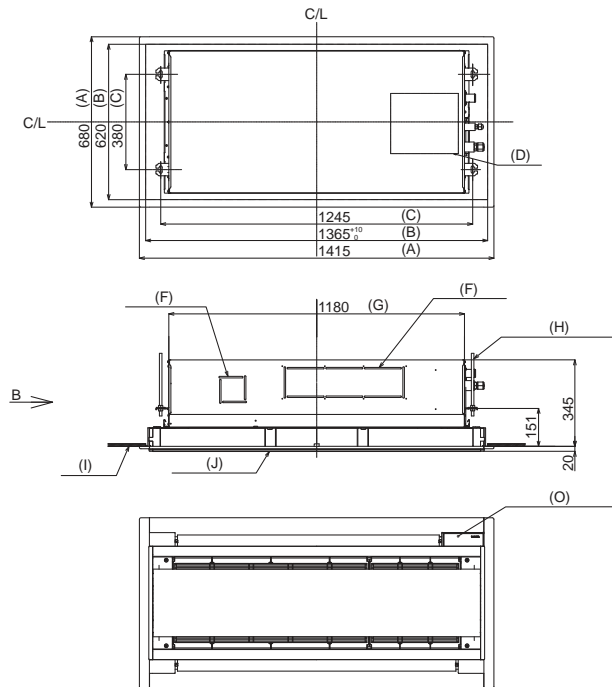

(A)	Panel external dimension	(I)	Ceiling bottom surface
(B)	Ceiling opening dimension	(J)	Ceiling panel (Sold separately)
(C)	Hanging bolt pitch	(K)	Refrigerant pipe connecting port (Liquid)
(D)	Electrical control box	(L)	Refrigerant pipe connecting port (Gas)
(E)	Knockout square hole for auxiliary fresh air flange For Dia. 150 (Sold separately)	(M)	Drain pipe connecting port (Be absolutely sure to use the flexible hose provided for the connection here.)
(F)	Knockout hole	(N)	Take-in port of wires
(G)	Unit external dimension	(O)	Wireless signal receiving unit mounting area (Sold separately)
(H)	Hanging bolt M10 or W3/8 (Locally procured)		

UP036 to UP056

(Unit: mm)

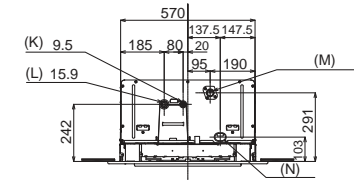
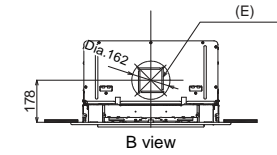
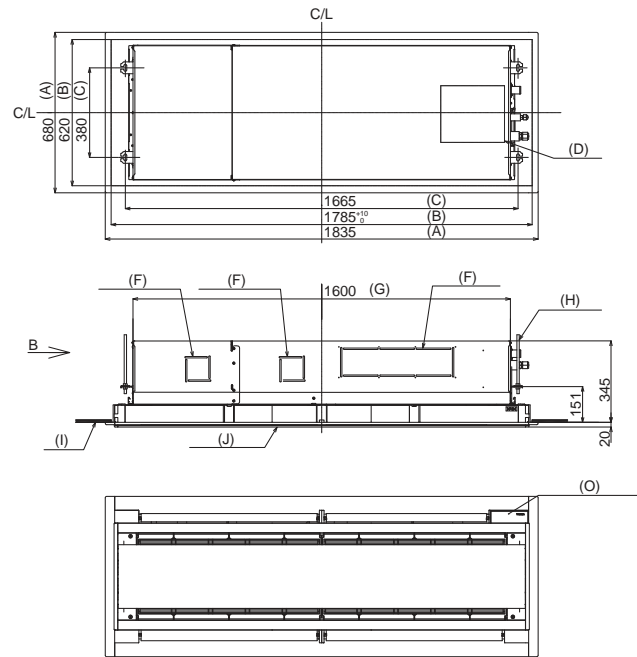

(A)	Panel external dimension	(I)	Ceiling bottom surface
(B)	Ceiling opening dimension	(J)	Ceiling panel (Sold separately)
(C)	Hanging bolt pitch	(K)	Refrigerant pipe connecting port (Liquid)
(D)	Electrical control box	(L)	Refrigerant pipe connecting port (Gas)
(E)	Knockout square hole for auxiliary fresh air flange For Dia.150 (Sold separately)	(M)	Drain pipe connecting port (Be absolutely sure to use the flexible hose provided for the connection here.)
(F)	Knockout hole	(N)	Take-in port of wires
(G)	Unit external dimension	(O)	Wireless signal receiving unit mounting area (Sold separately)
(H)	Hanging bolt M10 or W3/8 (Locally procured)		

■ Opening a ceiling and installation of hanging bolts

- Decide on the installation position and orientation of the indoor unit while factoring in "Selection of installation place" in this manual and the piping and wiring work to be performed after the indoor unit has been suspended from the ceiling.
- After the location of the indoor unit installation has been determined, open the ceiling and install hanging bolts.
- The dimensions of the ceiling opening and hanging bolt pitches are given in the outline drawing and the attached installation pattern.
- When a ceiling already exists, lay the drain pipe, refrigerant pipe, indoor unit / outdoor unit connection wires, and remote controller wires to their connection locations before hanging the indoor unit.

Procure hanging bolts and nuts for installing the indoor unit (these are not supplied).

Hanging bolt	M10 or W3/8	4 pieces
Nut	M10 or W3/8	12 pieces

How to use the installation pattern (accessory)

<For existing ceiling>

Use the installation pattern to position a ceiling opening and hanging bolts.

<For new ceiling>

Use the installation pattern to position the ceiling opening when hanging a ceiling.

- After the hanging bolts have been installed, install the indoor unit.
- Screw down the installation pattern on the ceiling panel mounting area of the indoor unit hanging fixtures. (Use the pattern fastening screws: M5 x l 16 (accessory).)
- When hanging a ceiling, open the ceiling along the outside dimensions of the installation pattern.

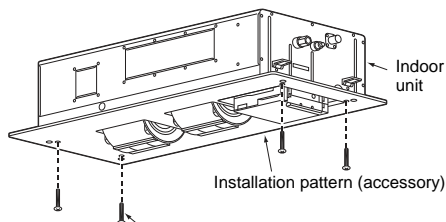

Use the pattern fastening screws: M5 x l 16 (Accessory). (These screws are used only to fasten the installation pattern. When mounting the ceiling panel, use the special-purpose mounting screws provided with the ceiling panel (sold separately).)

Treatment of ceiling



The ceiling differs according to structure of building. For details, consult your constructor or interior finish contractor.

In the process after the ceiling board has been removed, it is important to reinforce ceiling foundation (frame) and to keep horizontal level of installed ceiling correctly in order to prevent vibration of ceiling board.

- Cut and remove the ceiling foundation.
- Reinforce the cut surface of ceiling foundation, and add ceiling foundation for fixing the end of ceiling board.

Installation of hanging bolt

Use M10 or W3/8 hanging bolts (4 pcs, locally procured). Matching to the existing structure, set pitch according to size in the unit external view as shown below.

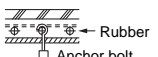
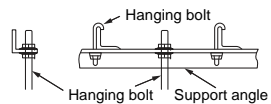
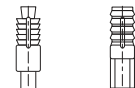
New concrete slab	
Install the bolts with insert brackets or anchor bolts.	
	
(Blade type bracket)	(Slide type bracket)
	
Rubber Anchor bolt (Pipe hanging anchor bolt)	
Steel flame structure	
Use existing angles or install new support angles.	
	
Hanging bolt Support angle	
Existing concrete slab	
Use a hole-in anchors, hole-in plugs, or a hole-in bolts.	
	

■ Installation of indoor unit

- Attach a nut (M10 or W3/8: locally procured) and the Dia.34 washer (supplied) to each hanging bolt.
- Insert a washer on both sides of the T groove of the hanging bracket of the indoor unit, and hang the indoor unit.

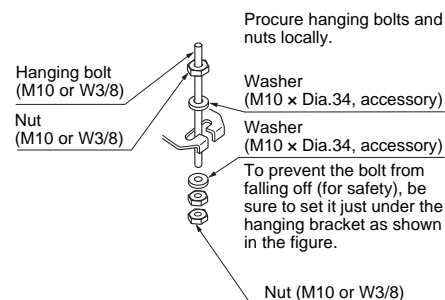

- Check that the four sides of the indoor unit are level using a level vial.
 - Detach the installation gauge (accessory) from the installation pattern.
 - Use the installation gauge to check and adjust the relative positions of the indoor unit and the ceiling opening as well as the suspension height. (Orientation of the installation gauge is printed on the gauge.)
- Check that the bottom panel of the indoor unit is positioned 77 mm higher than the bottom surface of the ceiling panel. (All four corners)
 - Check that the clearance between the outlet side (shorter side) of the indoor unit and ceiling panel is 25 mm.
 - Check that the clearance between the outlet side (longer side) of the indoor unit and ceiling panel is 74 mm.

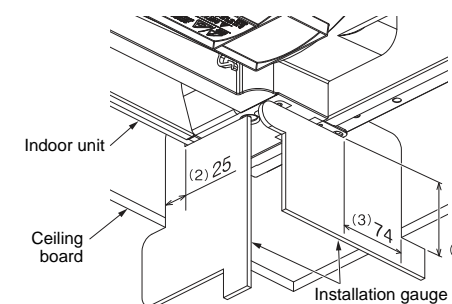
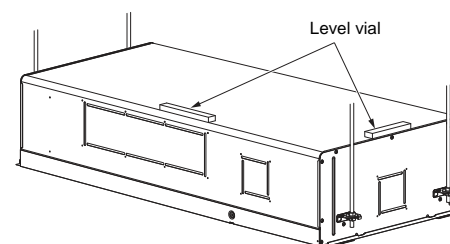

CAUTION

Before installing an indoor unit, be sure to remove the tape securing the fan and the bell mouth for UP007 to UP015 models and the tape securing the fan case for UP036 to UP056 models. Running the unit without removing the tape may damage the fan motor.

■ Installation of ceiling panel (sold separately)

Install the ceiling panel according to the Installation Manual attached with it after piping / wiring work has completed.

To install the ceiling panel, follow the instructions provided with the panel.

Check that installation of indoor unit and ceiling opening part is correct, and then install it.

CAUTION

Joint the connecting sections of ceiling panel, ceiling surface, ceiling panel and indoor unit closely. Any gap between them will cause air leakage and the generate condensation or water leakage.

■ Installation of remote controller (sold separately)

For installation of the remote controller, follow the Installation Manual attached with the remote controller.

- Do not leave the remote controller at a place exposed to the direct sunlight and near a stove.
- Install the remote controller after operating it and checking that the indoor unit can sense its signals properly. (Wireless type)
- Keep the remote controller at least one meter away from a TV set, radio or other devices. (Otherwise, the picture may be disrupted or the noise may affect the sound.) (Wireless type)

5 Drain piping

CAUTION

Following the installation manual, perform the drain piping work so that water is properly drained, and apply a heat insulation so as not to cause a dew condensation.

Inappropriate piping work may result in water leakage in the room and wet of furniture.

- Provide the indoor drain piping with proper heat insulation.
- Also be absolutely sure to provide the area where the pipe connects to the indoor unit with proper heat insulation. Improper heat insulation will cause condensation to form.
- Ensure that the drain pipe is sloping downward (at an angle of 1/100 or more), and do not run the pipe up and down (arched shape) or allow it to form traps. Doing so may cause abnormal sounds.
- Restrict the length of the traversing drain pipe to 20 meters or less. In the case of a long pipe, provide support brackets at intervals of 1.5 to 2 meters to prevent flapping.
- Install the collective piping as shown in the following figure.
- Do not provide any air vents. Otherwise, the drain water will spout, causing water to leak.
- Do not allow any force to be applied to the connection area with the drain pipe.
- A hard PVC pipe cannot be connected to the drain pipe connecting port of the indoor unit. Be absolutely sure to use the flexible hose provided for the connections with the drain pipe connecting port.
- Adhesive agents cannot be used for the drain pipe connecting port (hard socket) of the indoor unit. Be absolutely sure to secure the pipe using the hose bands provided. Use of an adhesive agent may damage the drain pipe connecting port or cause water to leak.

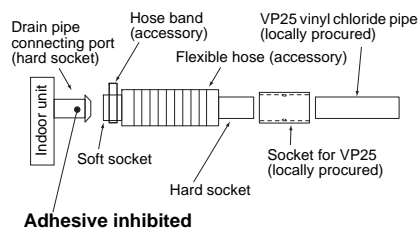
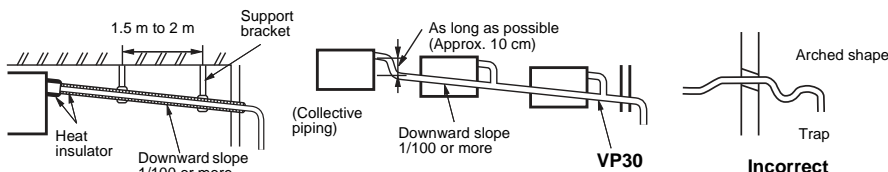

■ Piping / Heat insulating material

Require the following materials for piping and heat insulating at site.

Piping	Socket of hard vinyl chloride pipe for VP25
	Hard vinyl chloride pipe VP25 (Outer dia.: 32 mm)
Heat insulator	Foam polyethylene: Thickness 10 mm or more

■ Connecting flexible hose

- Insert the soft end socket of the flexible hose provided into the drain pipe connecting port of the indoor unit as far as it will go.
- Align the provided hose band with the end of the pipe connecting port, and tighten it securely.

CAUTION

- Be absolutely sure to secure the soft end socket with the hose band provided, and ensure that where the band is tightened is facing up.
- Do not use the flexible hose provided with the hose bent to an angle greater than 45° to avoid breakage or clogging.

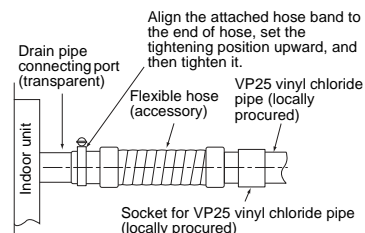
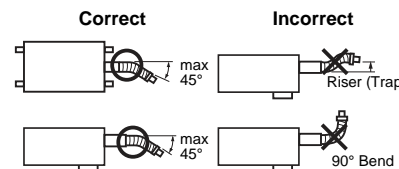

■ Connecting drain pipe

- Connect a hard socket (locally procured) to the hard socket of the attached supplied flexible hose.
- Connect a drain pipe (locally procured) to the connected hard socket.

CAUTION

- Connect hard vinyl chloride pipes securely using an adhesive for vinyl chloride to avoid water leakage.
- It takes some time until the adhesive is dried and hardened (refer to the manual of the adhesive). Do not apply stress to the joint with the drain pipe during this time period.

■ Drain up

When a down-gradient cannot be secured for the drain pipe, drain-up piping is possible.

- The height of the drain pipe must be 850 mm or less from the underside of the ceiling.
- Take the drain pipe out of the drain pipe joint with the indoor unit in 300 mm or less, and bend up the pipe vertically.
- Immediately after the pipe is bent up vertically, lay the pipe making a down-gradient.

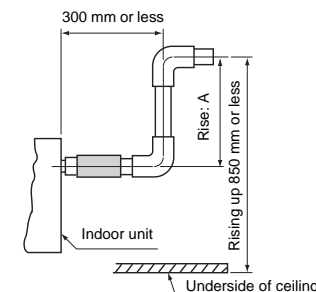

Model: MMU-	Ride: A
UP007 to UP015	609 mm or less
UP018 to UP056	559 mm or less

■ Check the draining

In the test run, check that water drain is properly performed and water does not leak from the connecting part of the pipes. When doing this, also check that no abnormal sounds are heard from the drain pump motor. Be sure to check draining also when installed in heating period.

When the electrical and wiring work has been completed

Before attaching the panel, pour some water by following the method shown in the following figure. Then, while performing a cooling operation, check that the water drains from the drain pipe connecting port (transparent) and that no water is leaking from the drain pipe.

When the electrical and wiring work has not been completed

- Disconnect the float switch connector (3P: red) from the connector (CN34: red) on the printed circuit board inside the electrical control box. (Before doing this, be absolutely sure that the power has been turned off.)
- Connect a 208 V to 240 V supply voltage to (L) and (N) on the power supply terminal block. (Never apply a 208 V to 240 V voltage to (Uv (U1)), (Uv (U2)), (A), (B) of the power supply terminal block. Otherwise, the printed circuit board may be damaged.)
- Pour the water by following the method shown in the following figure. (Amount of water poured: 1500 cc to 2000 cc)
- When the power is turned on, the drain pump automatically starts running. Check whether the water is draining from the drain pipe connecting port (transparent), and check that no water is leaking from the drain pipe.
- After checking that the water drains and there are no water leaks, turn off the power, connect the float switch connector to its original location (CN34) on the printed circuit board, and return the electrical control box to its original position.

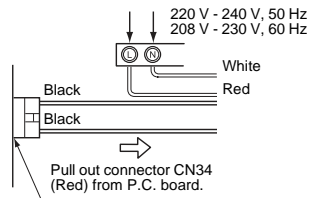

⚠ CAUTION

When pouring the water, pour it slowly. If it is poured with too much force, it will spread around the inside of the indoor unit, possibly causing the unit to malfunction.

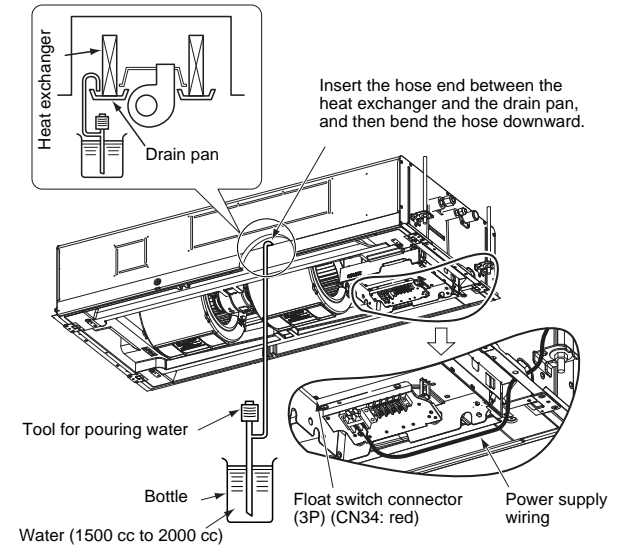

■ Perform heat insulating

- As shown in the figure, cover the flexible hose and hose band with the attached heat insulator up to the bottom of the indoor unit tightly.
- Cover the drain pipe tightly with a heat insulator locally procured so that it overlaps with the attached heat insulator of the drain connecting section.

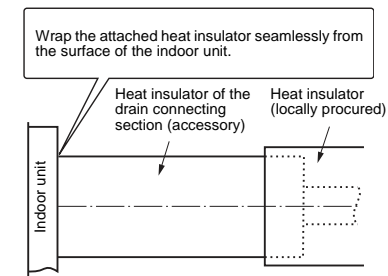

6 Refrigerant piping

⚠ CAUTION

Use flare nuts that are included with the unit. Using different flare nuts may cause refrigerant gas leakage.

■ Refrigerant piping

Use the following item for the refrigerant piping.

Material: Seamless phosphorous de-oxidized copper pipe.

6.35, 9.52 and 12.7 wall thickness 0.8 mm or more. 15.88 wall thickness 1.0 mm or more.

REQUIREMENT

When the refrigerant pipe is long, provide support brackets at intervals of 2.5 - 3 m to clamp the refrigerant pipe. Otherwise, abnormal sound may be generated.

⚠ CAUTION

IMPORTANT 4 POINTS FOR PIPING WORK

1. Reusable mechanical connectors and flared joints are not allowed indoors. When mechanical connectors are reused indoors, sealing parts shall be renewed. When flared joints are reused indoors, the flare part shall be re-fabricated.
2. Tight connection (between pipes and unit)
3. Evacuate the air in the connecting pipes by using VACUUM PUMP.
4. Check the gas leakage. (Connected points)

■ Pipe size

Model MMU-	Outside diameter size (mm)	
	Gas side	Liquid side
UP007 to UP012	9.5	6.4
UP015, UP018	12.7	6.4
UP024 to UP056	15.9	9.5

■ Permissible piping length and height difference

They vary according to the outdoor unit. For details, refer to the Installation Manual attached to the outdoor unit.

Flaring

1. Cut the pipe with a pipe cutter. Remove burrs completely. Remaining burrs may cause gas leakage.
2. Insert a flare nut into the pipe, and flare the pipe. As the flaring sizes of R32 or R410A differ from those of refrigerant R22, the flare tools newly manufactured for R32 or R410A are recommended. However, the conventional tools can be used by adjusting projection margin of the copper pipe.

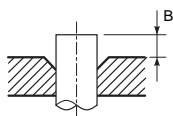

▼ Projection margin in flaring: B (Unit: mm)

Rigid (Clutch type)

Outside diameter size	R32 or R410A tool used	Conventional tool used
6.4, 9.5	0 - 0.5	1.0 - 1.5
12.7, 15.9		

▼ Flaring diameter size: A (Unit: mm)

Outside diameter size	A ⁺⁰ _{-0.4}
6.4	9.1
9.5	13.2
12.7	16.6
15.9	19.7

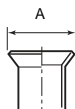

⚠ CAUTION

- Do not scratch the inner surface of the flared part when removing burrs.
- Flare processing under the condition of scratches on the inner surface of flare processing part will cause refrigerant gas leak.
- Check that the flared part is not scratched, deformed, stepped, or flattened, and that there are no chips adhered or other problems, after flare processing.
- Do not apply refrigerating machine oil to the flare surface.

Tightening connection

⚠ CAUTION

Do not apply excessive torque. Otherwise, the nut may crack depending on the conditions.

Unit: N•m

Outside diameter size	Tightening torque
6.4 mm	14 - 18
9.5 mm	34 - 42
12.7 mm	49 - 61
15.9 mm	68 - 82

▼ Tightening torque of flare pipe connections

Incorrect connections may cause not only a gas leak, but also a trouble of the refrigeration cycle.

Align the centers of the connecting pipes and tighten the flare nut as far as possible with your fingers. Then tighten the nut with wrenches and torque wrench as shown in the figure.

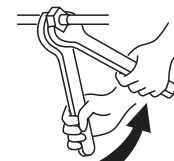

Work using two wrenches

REQUIREMENT

Tightening with an excessive torque may crack the nut depending on installation conditions. Tighten the nut within the specified tightening torque.

■ Airtight test / Air purge, etc.

For air tightness test, vacuum drying and adding refrigerant, refer to the Installation Manual attached to the outdoor unit.

⚠ CAUTION

Do not supply power to the indoor unit until the airtight test and vacuuming are completed. (If the indoor unit is powered on, the pulse motor valve is fully closed, which extends the time for vacuuming.)

■ Open the valve fully

Open the valve of the outdoor unit fully.

■ Heat insulation process

Apply heat insulation for the pipes separately at liquid side and gas side.

- For the heat insulation to the pipes at gas side, use the material with heat-resisting temperature 120°C or higher.
- To use the attached heat insulation pipe, apply the heat insulation to the pipe connecting section of the indoor unit securely without gap.

REQUIREMENT

- Apply the heat insulation to the pipe connecting section of the indoor unit securely up to the root without exposure of the pipe. (The pipe exposed to the outside causes water leak.)
- Wrap heat insulator with its slits facing up (ceiling side).

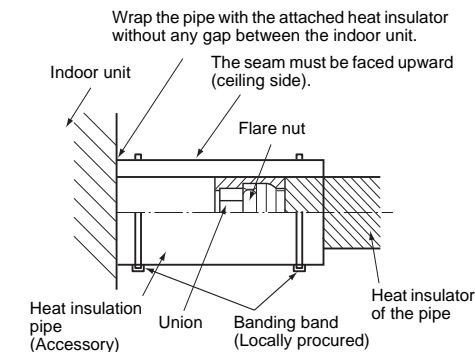

7 Electrical connection

⚠ WARNING

- Use the specified wires for wiring connection to the terminals. Securely fix them to prevent external forces applied to the terminals from affecting the terminals.
Incomplete connection or fixation may cause a fire or other trouble.
- Connect earth wire. (grounding work)
Incomplete earthing cause an electric shock.
Do not connect earth wires to gas pipes, water pipes, lightning conductor or telephone earth wires.
- Appliance shall be installed in accordance with national wiring regulations.
Capacity shortage of power circuit or incomplete installation may cause an electric shock or a fire.

⚠ CAUTION

- The wire size and wire length of the communication line differs depending on the outdoor unit series to be connected.
- If incorrect / incomplete wiring is carried out, it will cause an electrical fire or smoke.
- Install an earth leakage breaker that is not tripped by shock waves.
If an earth leakage breaker is not installed, an electric shock may be caused.
- Use the cord clamps attached to the product.
- Do not damage or scratch the conductive core and inner insulator of power and control wires when peeling them.
- Use the power supply wire and control wires of specified thickness, type, and protective devices required.
- Do not connect 208 to 240 V power to the terminal blocks (Uv (U1)), (Uv (U2)), (A), (B) for control wiring. (Otherwise, the system will fail.)
- Perform the electric wiring so that it does not come to contact with the high-temperature part of the pipe.
The coating may melt resulting in an accident.
- Be careful of fan operation when the circuit breaker is turned on. When the leak detector is connected in combination with the R32 outdoor unit, if the refrigerant leak detection sensor detects the refrigerant leak, a fan automatically rotates even while an air conditioner stops. Be careful not to be injured by the fan.

REQUIREMENT

- For power supply wiring, strictly conform to the Local Regulation in each country.
- For wiring of power supply of the outdoor units, follow the Installation Manual of each outdoor unit.
- After connecting wires to the terminal blocks, provide a trap and fix wires with the cord clamp.
- Run the refrigerant piping line and communication line in the same line.
- Do not turn on the power of the indoor unit until vacuuming of the refrigerant pipes completes.

■ Power supply wire and communication wires specifications

Power supply wire and communication wires are locally procured.

For the power supply specifications, follow to the table below. If capacity is little, it is dangerous because overheat or burnout may be caused.

For specifications of the power capacity of the outdoor unit and the power supply wires, refer to the Installation Manual attached to the outdoor unit.

Indoor unit power supply

- For the power supply of the indoor unit, prepare the exclusive power supply separated from that of the outdoor unit.
- Arrange the power supply, circuit breaker, and main switch of the indoor unit connected to the same outdoor unit so that they are commonly used.
- Power supply wire specification: Cable 3-core 2.5 mm², in conformity with Design 60245 IEC 57.

■ Power supply

Power supply	220 - 240 V, 50 Hz 208 - 230 V, 60 Hz	
Power supply switch / circuit breaker or power supply wiring / fuse rating for indoor units should be selected by the accumulated total current values of the indoor units.		
Power supply wiring	Below 50 m	3 x 2.5 mm ² (power supply and earth)

Control wiring, Central controller wiring

- 2-core with non-polarity wires are used for the Control wiring between indoor unit and outdoor unit and Central controller wiring.
- To prevent noise trouble, use 2-core shield wire.

■ Communication line

TU2C-Link models (U series) can be combined with TCC-Link models (other than U series).

For details of communication type, refer to the following table.

Communication type and model names

Communication type	TU2C-Link (U series and future models)	TCC-Link (Other than U series)
Outdoor unit	MMY-MUP***, MMY-SUG***, MCY-MUG*** ↑ This letter indicates U series model.	Other than U series MMY-MAP***, MMY-SAP*** MCY-MHP***
Indoor unit	MM*-UP*** ↑ This letter indicates U series model.	Other than U series MM*-AP***
Wired remote controller	RBC-A**U*** ↑ This letter indicates U series model.	Other than U series
Wireless remote controller kit & receiver unit	RBC-AXU*** ↑ This letter indicates U series model.	Other than U series
Remote sensor	TCB-TC**U*** ↑ This letter indicates U series model.	Other than U series

U series outdoor unit: SMMS-u, SMMS[∞], SHRM-A, Mini-SMMS

Other than U series outdoor unit: SMMS-i, SMMS-e, SHRM-e, SMMS-7 etc.

<In the case of combining with U series outdoor unit>

Follow the wiring specifications in the table below even when units other than U series are mixed in the indoor units and remote controllers to be connected.

Uv line and Uc line (L2, L3, L4) (2-core shield wire, non-polarity)	Wire size: 1.0 to 1.5 mm ² (Up to 1000 m)
Uh line (L1) (2-core shield wire, non-polarity)	Wire size: 1.0 to 1.5 mm ² (Up to 1000 m) 2.0 mm ² (Up to 2000 m)

- **U (v, h, c)** line means of control wiring.
 - Uv** line: Between indoor and outdoor units.
 - Uh** line: Central control line.
 - Uc** line: Between outdoor and outdoor units.
- **Uv** line and **Uc** line are independent from another refrigerant line. Total length of **Uv** and **Uc** lines (**L3 + L4**) in each refrigerant line is up to 1000 m.

REQUIREMENT

For connection of Uv line / Uc line or Uh line, wire each line using wires with the same type and size. If different wire types and size are mixed and used in a system, communication trouble is caused.

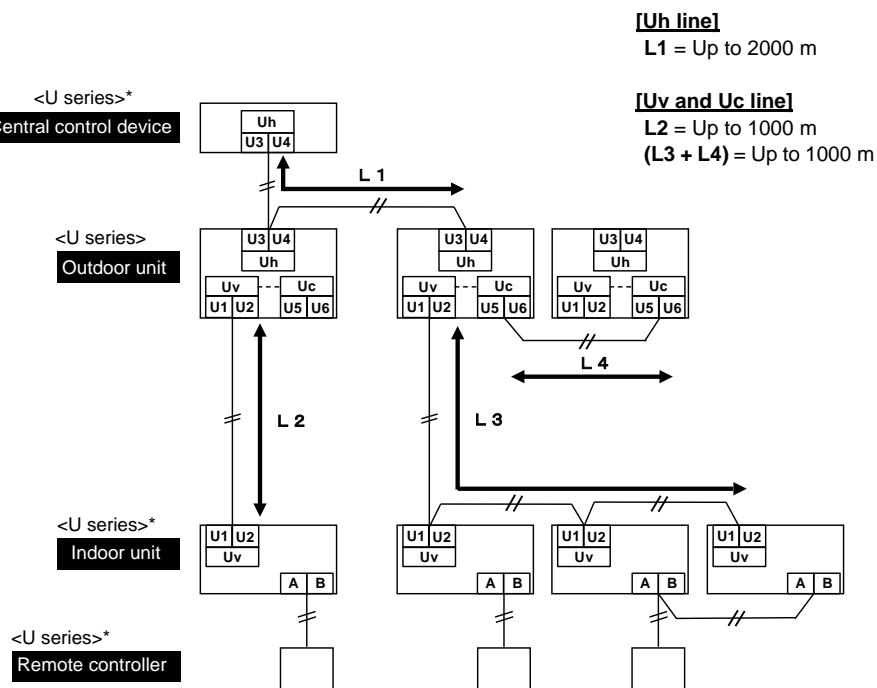

*Even if the indoor units, the remote controllers, and the central control device are models other than U series, their system diagrams for the wiring specifications are the same as the system diagram above.

<In the case of combining with outdoor units other than U series outdoor unit>

Control wiring between indoor units, and outdoor unit (L2, L3) (2-core shield wire, non-polarity)	Wire size: 1.25 mm ² (Up to 1000 m)
Central control line wiring (L1) (2-core shield wire, non-polarity)	Wire size: 2.0 mm ² (Up to 2000 m)
Control wiring between outdoor units (L4) (2-core shield wire, non-polarity)	Wire size: 1.25 to 2.0 mm ² (Up to 100 m)

- The length of the communication line (L1+L2+L3) means the total length of the inter-unit wire length between indoor and outdoor units added with the central control system wire length.

REQUIREMENT

For connection of between indoor and outdoor units line / between outdoor and outdoor units line or central control line, wire each line using wires with the same type and size. If different wire types and size are mixed and used in a system, communication trouble is caused.

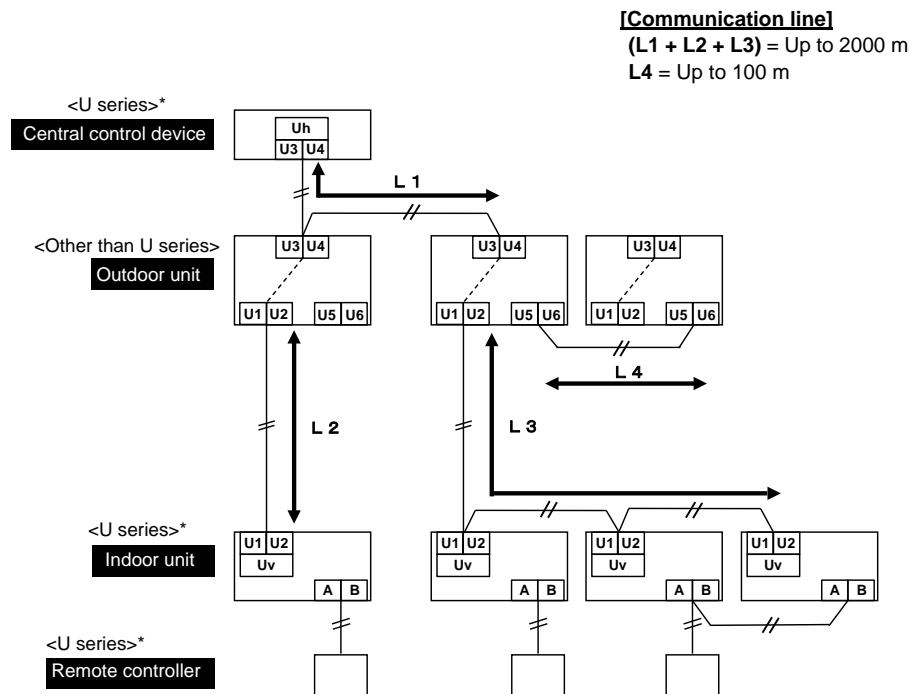

*Even if the indoor units, the remote controllers, and the central control device are models other than U series, their system diagrams for the wiring specifications are the same as the system diagram above.

Remote controller wiring

- 2-core with non-polarity wire is used for the remote controller wiring and group remote controllers wiring.

Remote controller wiring, remote controller inter-unit wiring	Wire size: 0.5 to 2.0 mm ²	
Total wire length of remote controller wiring and remote controller inter-unit wiring = L + L1 + L2 + ... Ln	In case of one remote controller	Up to 500 m
	In case of two remote controller	Up to 400 m
Max. length of each remote control wiring between indoor units = L1, L2, ..., Ln	Up to 200 m	

CAUTION

- The remote controller wire (Communication line) and AC 208 to 240 V wires cannot be parallel to contact each other and cannot be stored in the same conduits. If doing so, a trouble may be caused on the control system due to noise or other factor.
- If U series models (TU2C-Link) are combined with models other than U series (TCC-Link), the wiring specifications and maximum number of connect-able indoor units will be changed. Pay attentions to their communication specifications when carrying out the installation, maintenance, or repair. For its details, refer to the "Communication line" in 7 Electrical connection.

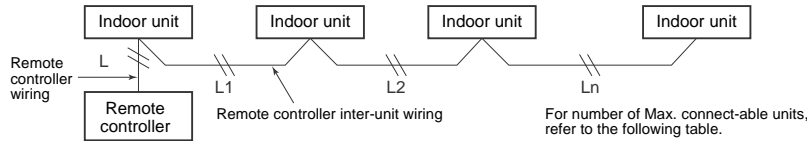

Max. number of connect-able indoor units, and communication type

Outdoor unit	Unit type							
	U series	U series	U series	U series	*	*	*	*
Indoor unit	U series	U series	*	*	U series	U series	*	*
Remote controller	U series	*	U series	*	U series	*	U series	*
Remote sensor	U series	*	U series	*	U series	*	U series	*
Communication type	TU2C-Link				TCC-Link			
Max. number of connect-able units	16				8			

*: Other than U series

REQUIREMENT

After carrying out installation of additional indoor unit, relocation, or repairing, set the addresses again. For its detail, refer to the Installation Manual attached to the outdoor unit.

Wiring between indoor and outdoor units

NOTE

A wiring diagram below is an example for connection to SMMS-u series. For connecting to other outdoor unit series, refer to the Installation Manual attached to the outdoor unit to be connected.

Wiring example

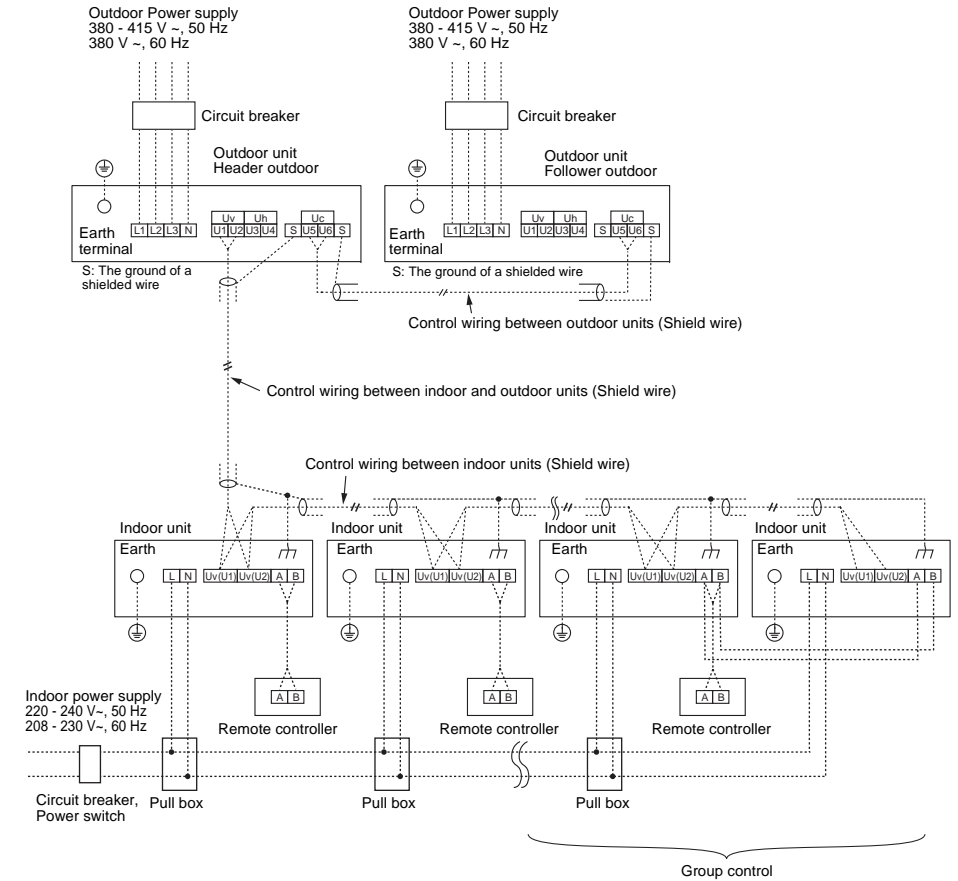

■ Wire connection

REQUIREMENT

- Connect the wires matching the terminal numbers. Incorrect connection causes a trouble.
- Route the wire through the wire connection port of the indoor unit.
- The low-voltage circuit is provided for the control wire and remote controller wire. (Do not connect the high-voltage circuit.)

1. Remove the two screws used to mount the cover of the electrical parts box, and slide the cover to open it. (The cover of the electric parts box remains hanged to the hinge.)
2. Connect the power supply wire, control wiring and remote controller wire to the terminal block of the electrical parts box.
3. Tighten the screws of the terminal block, and fix the wires with cord clamp attached to the electric parts box. (Do not apply tension to the connecting section of the terminal block.)
4. Using the attached thermal insulation material, seal the pipe connecting port. Otherwise, dewing may be caused.
5. Mount the cover of the electric parts box without pinching wires. (Mount the cover after wiring on the ceiling panel.)
6. Pass the wires underneath the flashing protrusion of the drain pan, and stow them inside the wiring guide of the electrical parts box cover.

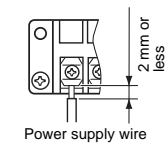
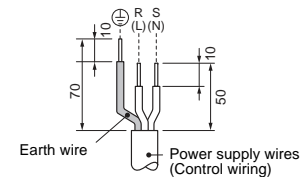
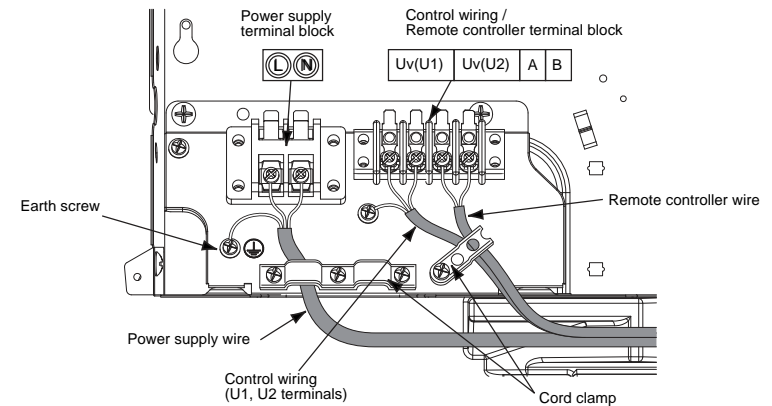
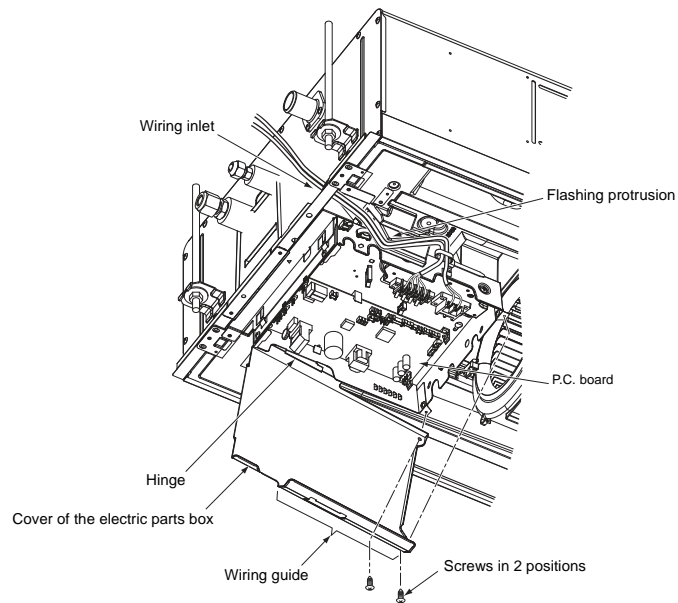
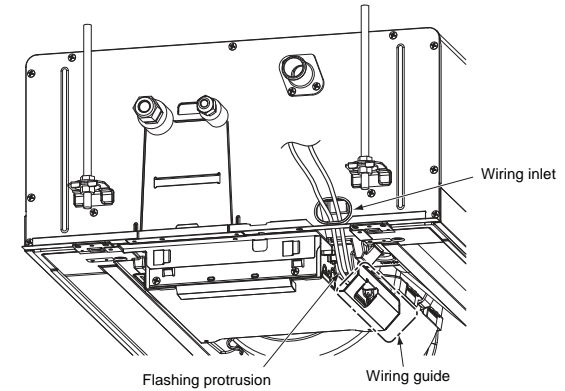

See the figure on the left for system interconnection wires to the terminal block.

Remote controller wiring

Strip off approx. 9 mm the wire to be connected.

Wiring diagram

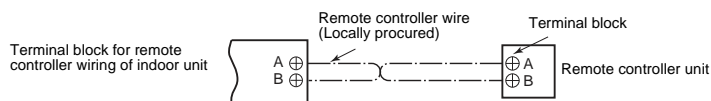

Address setup

Set up the addresses as per the Installation Manual supplied with the outdoor unit.

Wiring on the ceiling panel

According to the Installation Manual of the ceiling panel, connect the connector (20P: White) of the ceiling panel to the connector (CN510: White) on P.C. board of the electrical control box.

Wiring of other optional parts

For the wiring method of other optional parts, refer to the optional parts Installation Manual.

8 Applicable controls

REQUIREMENT

When the air conditioner is used for the first time, it will take some moments after the power has been turned on before the remote controller becomes available for operations: This is normal and is not indicative of trouble.

- Concerning the automatic addresses (The automatic addresses are set up by performing operations on the outdoor interface circuit board.)
While the automatic addresses are being set up, no remote controller operations can be performed. Setup takes up to 10 minutes (usually about 5 minutes).
- When the power is turned on after automatically address setup, it takes up to 10 minutes (usually about 3 minute) for the outdoor unit to start operating after the power has been turned on.

Before the air conditioner was shipped from the factory, all units are set to [STANDARD] (factory default). If necessary, change the indoor unit settings.

The settings are changed by operating the wired remote controller.

* The settings cannot be changed using only a wireless remote controller and simple remote controller by itself so install a wired remote controller separately as well.

Applicable controls setup (settings at the site)

Remote controller model name:

RBC-ASCU11-*

Basic procedure

Be sure to stop the air conditioner before making settings.

(Change the setup while the air conditioner is not working.)

CAUTION

Set only the Code No. shown in the following table: Do NOT set any other Code No.

If a Code No. not listed is set, it may not be possible to operate the air conditioner or other trouble with the product may result.

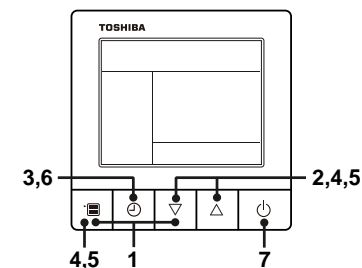

1 Push and hold menu button and [▽] setting button simultaneously for 10 seconds or more.

- After a while, the display flashes as shown in the figure. "ALL" is displayed as indoor unit numbers during initial communication immediately after the power has been turned on.

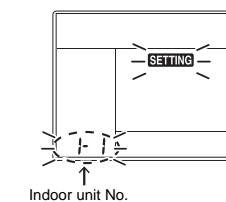

2 Each time [▽][△] setting button is pushed, indoor unit numbers in the group control change cyclically. Select the indoor unit to change settings for.

- The fan of the selected indoor unit runs and the louvers start swinging. The indoor unit can be confirmed for which to change settings.

3 Push OFF timer button to confirm the selected indoor unit.

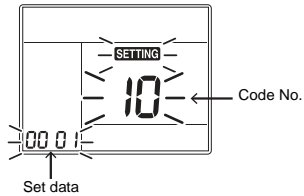

4 Push the menu button to make Code No. [**] flash. Change Code No. [**] with [▽][△] setting button.

5 Push the menu button to make Set data [****] flash. Change Set data [****] with [▽][△] setting button.

6 Push OFF timer button to complete the set up.

- To change other settings of the selected indoor unit, repeat from Procedure 4.

7 When all the settings have been completed, push ON/OFF button to finish the settings. (Return to the normal mode)

"SETTING" flashes and then the display content disappears and the air conditioner enters the normal stop mode. (The remote controller is unavailable while "SETTING" is flashing.)

- To change settings of another indoor unit, repeat from Procedure 1.

■ Installing indoor unit on high ceiling

When an indoor unit is installed on a ceiling higher than the standard height, make the high ceiling setting for fan speed adjustment.

Follow to the basic operation procedure (1 → 2 → 3 → 4 → 5 → 6 → 7).

- Specify [5d] for the Code No. in Procedure 4.
- Select the set data for Procedure 5 from the "Height list of ceiling possible to be installed" table in this manual.

Set data	Ceiling height
0000	Standard (Factory default)
0001	High ceiling (1)
0003	High ceiling (3)

Remote controller-less setting

Change the high-ceiling setting with the DIP switch on the P.C. board.

* Once the Set data has been changed, though it can be freely set to 0001 or 0003, to reset it to 0000 (factory default), it need changing using remote controller (sold separately). After set data change, an air conditioner is operated. After setting has been completed, restart the air conditioner.

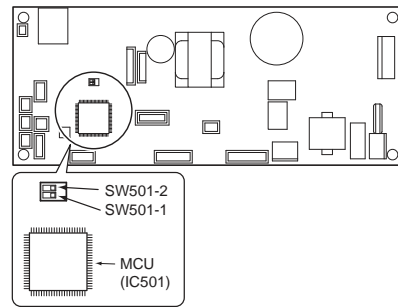

Set data	Ceiling height	SW501-1	SW501-2
0000	Standard (Factory default)	OFF	OFF
0001	High ceiling (1)	ON	OFF
0003	High ceiling (3)	OFF	ON

◆ To restore the factory defaults

To return the DIP switch settings to the factory defaults, set SW501-1 and SW501-2 to OFF, connect a separately sold wired remote controller, and then set the data of Code No. [5d] to "0000".

■ To secure better effect of heating

When it is difficult to obtain satisfactory heating due to installation place of the indoor unit or structure of the room, the detection temperature of heating can be raised. Also use a circulator or other machinery to circulate heat air near the ceiling.

Follow to the basic operation procedure (1 → 2 → 3 → 4 → 5 → 6 → 7).

- Specify [06] for the Code No. in Procedure 4.
- For the set data in Procedure 5, select the set data of shift value of detection temperature to be set up from the following table.

Set data	Detection temperature shift value
0000	No shift
0001	+1°C
0002	+2°C (Factory default)
0003	+3°C
0004	+4°C
0005	+5°C
0006	+6°C

■ Filter sign setting

According to the installation condition, the filter sign term (Notification of filter cleaning) can be changed.

Follow to the basic operation procedure (1 → 2 → 3 → 4 → 5 → 6 → 7).

- Specify [01] for the Code No. in Procedure 4.
- For the set data in Procedure 5, select the set data of filter sign term from the following table.

Set data	Filter sign term
0000	None
0001	150 H
0002	2500 H (Factory default)
0003	5000 H
0004	10000 H

- The filter sign may be unavailable depending on the remote controllers.

■ Remote controller sensor

The temperature sensor of the indoor unit senses room temperature usually. Set the remote controller sensor to sense the temperature around the remote controller.

Select items following the basic operation procedure (1 → 2 → 3 → 4 → 5 → 6 → 7).

- Specify [32] for the Code No. in Procedure 4.
- Select the following data for the set data in Procedure 5.

Set data	0000	0001
Remote controller sensor	Not in use (Factory default)	In use

When flashes, the remote controller sensor is defective.

Select the set data [0000] (not in use) or replace the remote controller.

■ Group control

In a group control, a remote controller can control up to maximum 8 or 16 units. (Depending on the outdoor unit.)

- The wired remote controller only can control a group control. The wireless remote controller is unavailable for this control.
- For wiring procedure and wires of the individual line (Identical refrigerant line) system, refer to "7. Electrical connection" in this Manual.
- Wiring between indoor units in a group is performed in the following procedure.
- Connect the indoor units by connecting the remote controller wires from the remote controller terminal blocks (A, B) of the indoor unit connected with a remote controller to the remote controller terminal blocks (A, B) of the other indoor unit. (Non-polarity)
- For address setup, refer to the Installation Manual attached to the outdoor unit.

9 Test run

■ Before test run

- Before turning on the circuit breaker, carry out the following procedure.
 - 1) By using insulation tester (500 VMΩ), check that resistance of 1 MΩ or more exists between the terminal block L to N and the earth (grounding). If resistance of less than 1 MΩ is detected, do not run the unit.
 - 2) Check the valve of the outdoor unit being opened fully.
- To protect the compressor at activation time, leave power-ON for 12 hours or more for operating.
- Before starting a test run, be sure to set addresses following the Installation Manual supplied with the outdoor unit.

■ Execute a test run

Operate the unit with the remote controller as usual. For the procedure of the operation, refer to the Owner's Manual attached to the outdoor unit. A forced test run can be executed in the following procedure even if the operation stops by thermostat-OFF. In order to prevent a serial operation, the forced test run is released after 60 minutes have passed and returns to the usual operation.

⚠ CAUTION

- Do not use the forced test run for cases other than the test run because it applies an excessive load to the devices.

Wired remote controller

Be sure to stop the air conditioner before making settings.
(Change the setup while the air conditioner is not working.)

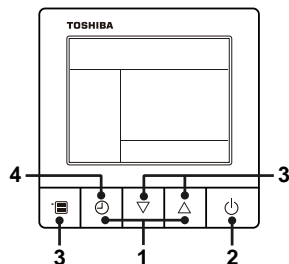

- 1 Push and hold OFF timer button and [△] setting button simultaneously for 10 seconds or more. [TEST] is displayed on the display part and the test run is permitted.

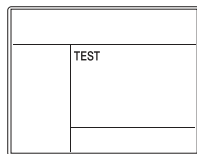

- 2 Push ON/OFF button.
- 3 Push menu button to select the operation mode. Select [Cool] or [Heat] with [▽] [△] setting button.
 - Do not run the air conditioner in a mode other than [Cool] or [Heat].
 - The temperature setting function does not work during test run.
 - The check code is displayed as usual.
- 4 After the test run, push OFF timer button to stop a test run.
([TEST] disappears on the display and the air conditioner enters the normal stop mode.)

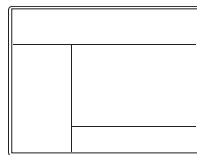

Wireless remote controller

- 1 Turn on the power of the air conditioner. When power is turned on for the first time after installation, it takes approx. 5 minutes until the remote controller becomes available. In the case of subsequent power-on, it takes approx. 1 minute until the remote controller becomes available. Execute a test run after the predetermined time has passed.
- 2 Push "ON/OFF" button on the remote controller, select [Cool] or [Heat] with "MODE" button, and then select [HIGH] with "FAN" button.

- 3

Cooling test run	Heating test run
Set the temperature to 17°C with the temp. setup buttons.	Set the temperature to 30°C with the temp. setup buttons.

- 4

Cooling test run	Heating test run
After confirming a signal receiving sound "beep" immediately set the temperature to 18°C with the temp. setup buttons.	After confirming a signal receiving sound "beep" immediately set the temperature to 29°C with the temp. setup buttons.

- 5

Cooling test run	Heating test run
After confirming a signal receiving sound "beep" immediately set the temperature to 17°C with the temp. setup buttons.	After confirming a signal receiving sound "beep" immediately set the temperature to 30°C with the temp. setup buttons.

- 6 Repeat procedures 4 → 5 → 4 → 5. Indicators "Operation" (green), "Timer" (green), and "Ready" (orange) in the wireless receiver section flash in approx. 10 seconds, and the air conditioner starts operation. If any of these indicators does not flash, repeat procedures 2 to 5.

- 7 Upon completion of the test run, push "ON/OFF" button to stop operation.

<Overview of test run operations using the wireless remote controller>

- ▼ Cooling test run:
ON/OFF → 17°C → 18°C → 17°C → 18°C → 17°C → 18°C → 17°C → (test run) → ON/OFF
- ▼ Heating test run:
ON/OFF → 30°C → 29°C → 30°C → 29°C → 30°C → 29°C → 30°C → (test run) → ON/OFF

10 Maintenance

⚠ CAUTION

- When connecting to an outdoor unit of R32 refrigerant and using a leak detector, be sure to turn on the circuit breaker after maintenance to detect the leakage of refrigerant and take safety measures.
- Do not clean the filter with all the hooks of the center panel disengaged and with only one or two wires still attached to the center panel. Doing so may cause the center panel to fall down, possibly causing injury to any individuals below.

Cleaning of air filter

- Clogging of the air filter reduce cooling / heating performance.

Cleaning of panel and air filter

1 Turn off the air conditioner

Set the circuit breaker to OFF.

2 Open the center panel

- Loosen the screws on the center panel holders fixed to the frame covers by turning them about three times. There is a frame cover on each long side of the panel.
- While removing the center panel, as the panel moves, the panel pushes the center panel holders and makes the holders slide.

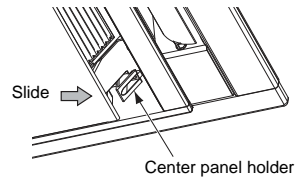
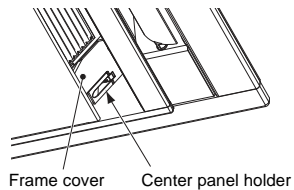
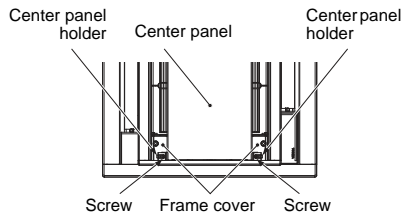

- The direction in which the center panel opens is fixed. The side that moves when the edge of the center panel is pushed upward is the end that opens; the end that barely moves is the hooking side.

- 1) While pushing the edge at the opening side of the center panel upward (1), pull the panel toward the opening side (2).
- 2) When the panel is pulled toward the opening side, the hooking side drops down by one step, and the hooks at the opening side are disengaged.

- * Take hold of the center panel near the hooks at both ends, and disengage the opening side hooks one at a time. If the center panel holders refuse to slide, loosen the screws a little more using the screwdriver.

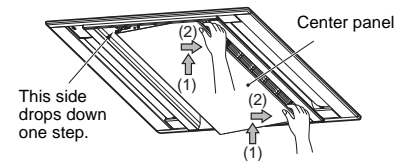

- 3) Once you have checked that the hooking side at both ends has dropped down by one step, slowly rotate the panel downward (3), and open it.

- * The center panel opens until there is no more slack in the wires at both ends.

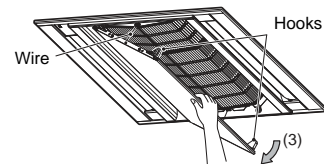

3 Remove the air filter

Take hold of the air filter knobs, and while pushing the filter diagonally (1), pull it downward (2), and remove it from the openings of the center panel.

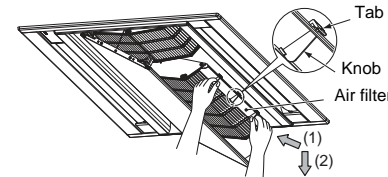

4 Remove the dust using a vacuum cleaner or rinsing it off in water

- When dust has accumulated on the filter, it can be cleaned effectively using lukewarm or cold water into which some neutral detergent has been dissolved.
- After rinsing off the filter, allow it dry out in the shade.

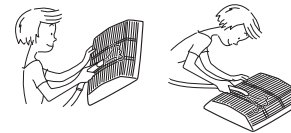

5 Mount the air filter

Insert the air filter until it touches the back surface. Take hold of the knobs, raise the air filter until it touches the back surface, left go of the knobs, and install.

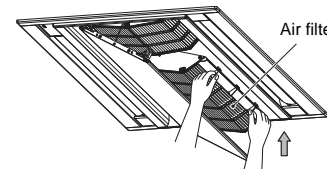

6 Close the center panel

- Slowly rotate the center panel upward (1), and close it.

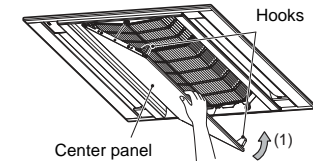

- With the opening side of the center panel now closed, while lifting the step of the hooking side (2), slide the center panel toward the hooking side (3), and secure it.

- * Take hold of the center panel near the hooks at both ends, and engage the hooks one at a time.

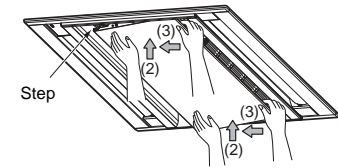

7 Return the center panel holders to their original positions, and tighten the two screws at the left and two screws at the right (total: 4 screws) using the screwdriver.

Make sure that the center panel is securely fixed with the center panel holders and does not open.

8 Check the filter

From the two intakes, check that the filter tabs are not disengaged. If they are, take hold of the knobs, and push the filter in so that the tabs are inserted.

9 Set the circuit breaker to ON.

⚠ CAUTION

Do not start the air conditioner while leaving the panel and air filter removed.

▼ Periodic Maintenance

- For environmental conservation, it is strongly recommended that the indoor and outdoor units of the air conditioner in use be cleaned and maintained regularly to ensure efficient operation of the air conditioner. When the air conditioner is operated for a long time, periodic maintenance (once a year) is recommended. Furthermore, regularly check the outdoor unit for rust and scratches, and remove them or apply rustproof treatment, if necessary.

As a general rule, when an indoor unit is operated for 8 hours or more daily, clean the indoor unit and outdoor unit at least once every 3 months. Ask a professional for this cleaning / maintenance work.

Such maintenance can extend the life of the product though it involves the owner's expense.

Failure to clean the indoor and outdoor units regularly will result in poor performance, freezing, water leakage, and even compressor failure.

Inspection before maintenance

Following inspection must be carried out by a qualified installer or qualified service person.

Parts	Inspection method
Heat exchanger*	Open the air intake grille to remove the bell mouth and the fan, and then check the heat exchanger if there is any clogging or damages.
Fan motor	Check if any abnormal noise can be heard.
Fan	Open the air intake grille and check the fan if there are any waggles, damages or adhesive dust.
Filter	Open the air intake grille and check if there are any stains or breaks on the filter.
Drain pan*	Remove the panel, the bell mouth and the drain pan, and then check if there is any clogging, abnormal smell or drain water pollution.

* Refer to the Service Manual for how to remove.

▼ Maintenance List

Part	Unit	Check (visual / auditory)	Maintenance
Heat exchanger	Indoor / outdoor	Dust / dirt clogging, scratches	Wash the heat exchanger when it is clogged.
Fan motor	Indoor / outdoor	Sound	Take appropriate measures when abnormal sound is generated.
Filter	Indoor	Dust / dirt, breakage	<ul style="list-style-type: none"> Wash the filter with water when it is contaminated. Replace it when it is damaged.
Fan	Indoor	<ul style="list-style-type: none"> Vibration, balance Dust / dirt, appearance 	<ul style="list-style-type: none"> Replace the fan when vibration or balance is terrible. Brush or wash the fan when it is contaminated.
Air intake / discharge grilles	Indoor / outdoor	Dust / dirt, scratches	Fix or replace them when they are deformed or damaged.
Drain pan	Indoor	Dust / dirt clogging, drain contamination	Clean the drain pan and check the downward slope for smooth drainage.
Ceiling panel, louvers	Indoor	Dust / dirt, scratches	Wash them when they are contaminated or apply repair coating.
Exterior	Outdoor	<ul style="list-style-type: none"> Rust, peeling of insulator Peeling / lift of coat 	Apply repair coating.

11 Troubleshooting

■ Confirmation and check

If a problem occurs with the air conditioner, the OFF timer indicator alternately shows the check code and the indoor Unit No. in which the problem occurred.

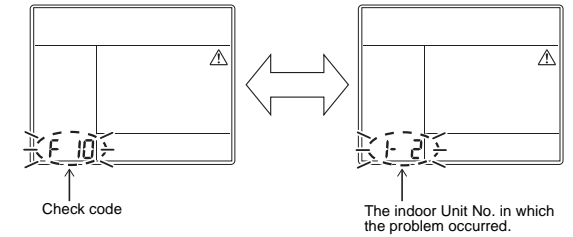

■ Troubleshooting history and confirmation

You can check the troubleshooting history with the following procedure if a problem occurs with the air conditioner. (The troubleshooting history records up to 4 incidents.)

You can check it during operation or when operation is stopped.

- If you check the troubleshooting history during OFF timer operation, the OFF timer will be canceled.

Procedure	Description of operation
1	<p>Push the OFF timer button for over 10 seconds and the indicators appear as an image indicating the troubleshooting history mode has been entered. If [Service check] is displayed, the mode enters in the troubleshooting history mode.</p> <ul style="list-style-type: none"> [01: Order of troubleshooting history] appears in the temperature indicator. The OFF timer indicator alternately shows the [check code] and the [indoor Unit No.] in which the problem occurred.
2	<p>Each time the setting button is pushed, the recorded troubleshooting history is displayed in sequence. The troubleshooting history appears in order from [01] (newest) to [04] (oldest).</p> <p>CAUTION</p> <p>In the troubleshooting history mode, DO NOT push the Menu button for over 10 seconds, doing so deletes the entire troubleshooting history of the indoor unit.</p>
3	<p>After you have finished checking, push the ON/OFF button to return to the regular mode.</p> <ul style="list-style-type: none"> If the air conditioner is operating, it remains operated even after the ON/OFF button has been pushed. To stop its operation, push the ON/OFF button again.

Check method

On the wired remote controller, central control remote controller and the interface P.C. board of the outdoor unit (I/F), a check display LCD (Remote controller) or 7-segment display (on the outdoor interface P.C. board) to display the operation is provided. Therefore the operation status can be known. Using this self-diagnosis function, a trouble or position with trouble of the air conditioner can be found as shown in the following table.

Check code list

The following list shows each check code. Find the check contents from the list according to part to be checked.

- In case of check from indoor remote controller: See "Wired remote controller display" in the list.
- In case of check from outdoor unit: See "Outdoor unit 7-segment display" in the list.
- In case of check from indoor unit with a wireless remote controller: See "Sensor block display of receiving unit" in the list.

○: Lighting, ◻: Flashing, ●: Goes off
 ALT: Flashing is alternately when there are two flashing LED.
 SIM: Simultaneous flashing when there are two flashing LED.
 I/F: Interface P.C. board

Check code		Wireless remote controller				Check code name	Judging device		
Wired remote controller display	Outdoor unit 7-segment display		Sensor block display of receiving unit						
		Auxiliary code		Operation	Timer	Ready	Flash		
E01	—	—		◻	●	●		Communication trouble between indoor unit and remote controller (Detected at remote controller side)	Remote controller
E02	—	—		◻	●	●		Remote controller transmission trouble	Remote controller
E03	—	—		◻	●	●		Communication trouble between indoor unit and remote controller (Detected at indoor unit side)	Indoor unit
E04	—	—		●	●	◻		Communication circuit trouble between indoor / outdoor unit (Detected at indoor unit side)	Indoor unit
E06	E06	No. of indoor units in which sensor has been normally received		●	●	◻		Decrease of No. of indoor units	I/F
—	E07	—		●	●	◻		Communication circuit trouble between indoor / outdoor unit (Detected at outdoor unit side)	I/F
E08	E08	Duplicated indoor unit addresses		◻	●	●		Duplicated indoor unit addresses	Indoor unit • I/F
E09	—	—		◻	●	●		Duplicated master remote controllers	Remote controller
E10	—	—		◻	●	●		Communication trouble between indoor unit MCU	Indoor unit
E11	—	—		◻	●	●		Communication trouble between Application control kit and indoor unit	Indoor unit Application control kit
E12	E12	01: Indoor/Outdoor units communication 02: Outdoor/Outdoor units communication		◻	●	●		Automatic address start trouble	I/F
E15	E15	—		●	●	◻		No indoor unit during automatic addressing	I/F
E16	E16	00: Capacity over 01 -: No. of connected units		●	●	◻		Capacity over / No. of connected indoor units	I/F
E17	—	—		◻	●	●		Communication trouble between indoor unit and Flow Selector unit	Indoor unit
E18	—	—		◻	●	●		Communication trouble between header and follower units	Indoor unit
E19	E19	00: Header is not detected 02: Two or more header units		●	●	◻		Outdoor header units quantity trouble	I/F
E20	E20	01: Outdoor unit of other line connected 02: Indoor unit of other line connected		●	●	◻		Other line connected during automatic address	I/F
E23	E23	—		●	●	◻		Sending trouble in communication between outdoor units Trouble in number of heat storage units (trouble with reception)	I/F
E25	E25	—		●	●	◻		Duplicated follower outdoor addresses	I/F
E26	E26	No. of outdoor units which received signal normally		●	●	◻		Decrease of No. of connected outdoor units	I/F
E28	E28	Detected outdoor unit number		●	●	◻		Follower outdoor unit trouble	I/F
E31	E31	*1 Inverter quantity information		●	●	◻		Inverter communication trouble	I/F
F01	—	—		◻	◻	●	ALT	Indoor unit TCJ sensor trouble	Indoor unit
F02	—	—		◻	◻	●	ALT	Indoor unit TC2 sensor trouble	Indoor unit
F03	—	—		◻	◻	●	ALT	Indoor unit TC1 sensor trouble	Indoor unit
F04	F04	—		◻	◻	○	ALT	TD1 sensor trouble	I/F
F05	F05	—		◻	◻	○	ALT	TD2 sensor trouble	I/F

Check code		Wireless remote controller				Check code name	Judging device	
Wired remote controller display	Outdoor unit 7-segment display		Sensor block display of receiving unit					
		Auxiliary code	Operation	Timer	Ready			Flash
F06	F06	01: TE1 sensor 02: TE2 sensor 03: TE3 sensor	☐	☐	○	ALT	TE1,TE2 or TE3 sensor trouble	I/F
F07	F07	01: TL1 sensor 02: TL2 sensor 03: TL3 sensor	☐	☐	○	ALT	TL1,TL2 or TL3 sensor trouble	I/F
F08	F08	—	☐	☐	○	ALT	TO sensor trouble	I/F
F09	F09	01: TG1 sensor 02: TG2 sensor 03: TG3 sensor	☐	☐	○	ALT	TG1,TG2 or TG3 sensor trouble	I/F
F10	—	—	☐	☐	●	ALT	Indoor unit TA sensor trouble	Indoor unit
F11	—	—	☐	☐	●	ALT	TF sensor trouble	Indoor unit
F12	F12	01: TS1 sensor 03: TS3 sensor 04: TS3 sensor disconnect	☐	☐	○	ALT	TS1 or TS3 sensor trouble	I/F
F13	F13	1*: Compressor 1 side 2*: Compressor 2 side	☐	☐	○	ALT	TH sensor trouble	Compressor inverter
F15	F15	—	☐	☐	○	ALT	Outdoor unit temp. sensor miswiring (TE, TL)	I/F
F16	F16	—	☐	☐	○	ALT	Outdoor unit pressure sensor miswiring (Pd, Ps)	I/F
F22	F22	—	☐	☐	○	ALT	TD3 sensor trouble	I/F
F23	F23	—	☐	☐	○	ALT	Ps sensor trouble	I/F
F24	F24	—	☐	☐	○	ALT	Pd sensor trouble	I/F
F29	—	—	☐	☐	●	SIM	Indoor unit other trouble	Indoor unit
F30	F30	—	☐	☐	○	SIM	Occupancy sensor trouble	Indoor unit
F31	F31	—	☐	☐	○	SIM	Indoor unit EEPROM trouble	I/F
H01	H01	1*: Compressor 1 side 2*: Compressor 2 side	●	☐	●		Compressor break down	Compressor inverter
H02	H02	1*: Compressor 1 side 2*: Compressor 2 side	●	☐	●		Compressor trouble (lock)	Compressor inverter
H03	H03	1*: Compressor 1 side 2*: Compressor 2 side	●	☐	●		Current detect circuit system trouble	Compressor inverter
H04	H04	—	●	☐	●		Compressor 1 case thermostat operation	I/F
H05	H05	—	●	☐	●		TD1 sensor miswiring	I/F
H06	H06	—	●	☐	●		Low pressure protective operation	I/F
H07	H07	—	●	☐	●		Oil level down detective protection	I/F
H08	H08	01: TK1 sensor trouble 02: TK2 sensor trouble 03: TK3 sensor trouble 04: TK4 sensor trouble 05: TK5 sensor trouble	●	☐	●		Oil level detective temp. sensor trouble	I/F
H14	H14	—	●	☐	●		Compressor 2 case thermostat operation	I/F
H15	H15	—	●	☐	●		TD2 sensor miswiring	I/F
H16	H16	01: TK1 oil circuit system trouble 02: TK2 oil circuit system trouble 03: TK3 oil circuit system trouble 04: TK4 oil circuit system trouble 05: TK5 oil circuit system trouble	●	☐	●		Oil level detective circuit trouble	I/F
H17	H17	1*: Compressor 1 side 2*: Compressor 2 side	●	☐	●		Compressor trouble (Step out)	I/F
H25	H25	—	●	☐	●		TD3 sensor miswiring	I/F
J02	—	—	●	☐	☐	SIM	Communication trouble between control boards in Flow Selector unit	Indoor unit

Check code			Wireless remote controller				Check code name	Judging device
Wired remote controller display	Outdoor unit 7-segment display		Sensor block display of receiving unit					
		Auxiliary code	Operation	Timer	Ready	Flash		
J03	—	—	●	□	□	SIM	Duplicated Flow Selector unit addresses	Indoor unit
J10	J10	Detected indoor unit address	●	□	□	SIM	Flow Selector unit overflow trouble	Indoor unit
J11	—	—	●	□	□	SIM	Flow Selector unit temperature sensor (TCS) trouble	Indoor unit
J29	—	—	●	□	□	SIM	Refrigerant leak detection sensor trouble	Indoor unit
J30	J30	Detected indoor unit address *Not displayed depending on the DN code (I.DN) setting	●	□	□	SIM	Refrigerant leak detection	Indoor unit
J31	—	—	●	□	□	SIM	Refrigerant leak detection sensor exceeding its life of the product	Indoor unit
L02	L02	Detected indoor unit address	□	●	□	SIM	Model mismatch of indoor and outdoor unit Indoor unit incompatible with A2L (R32) refrigerant	I/F
L03	—	—	□	●	□	SIM	Indoor unit header unit duplicated	Indoor unit
L04	L04	—	□	○	□	SIM	Outdoor unit line address duplicated	I/F
L05	—	—	□	●	□	SIM	Duplicated indoor units with priority (Displayed in indoor unit with priority)	I/F
L06	L06	No. of indoor units with priority	□	●	□	SIM	Duplicated indoor units with priority (Displayed in unit other than indoor unit with priority)	I/F
L07	—	—	□	●	□	SIM	Group line in individual indoor unit	Indoor unit
L08	L08	—	□	●	□	SIM	Indoor unit group/Address unset	Indoor unit, I/F
L09	—	—	□	●	□	SIM	Indoor unit capacity unset	Indoor unit
L10	L10	—	□	○	□	SIM	Outdoor unit capacity unset	I/F
L11	L11	Detected indoor unit address	□	○	□	SIM	Flow Selector unit not connected	I/F
L12	L12	01: Flow Selector unit installation trouble	□	○	□	SIM	Flow Selector unit system trouble	I/F
L13	L13	Detected indoor unit address	□	○	□	SIM	Safety device setting unmatched	I/F
L14	L14	Detected indoor unit address	□	○	□	SIM	Safety device nonconformity	I/F
L17	L17	—	□	○	□	SIM	Outdoor unit type mismatch trouble	I/F
L18	L18	Detected indoor unit address	□	○	□	SIM	Flow Selector unit trouble	I/F
L20	—	—	□	○	□	SIM	Duplicated central control addresses	Indoor unit
L22	—	—	□	○	□	SIM	There is a DX-kit (heat source capacity command) non-compliant machine in the group (DDC control, TA control and TF control are mixed)	Indoor unit
L24	L24	01: Duplication of Flow Selector unit address 02: Indoor unit operation mode priority setting	□	○	□	SIM	Flow Selector unit setting trouble	I/F
L28	L28	—	□	○	□	SIM	Too many outdoor units connected	I/F
L29	L29	*1 Inverter quantity information	□	○	□	SIM	No. of inverter trouble	I/F
L30	L30	Detected indoor unit address	□	○	□	SIM	Indoor unit outside interlock	Indoor unit
—	L31	—	—	—	—	—	Extended I/C trouble	I/F
P01	—	—	●	□	□	ALT	Indoor fan motor trouble	Indoor unit
P03	P03	—	□	●	□	ALT	Discharge temp. TD1 trouble	I/F
P04	P04	1*: Compressor 1 side 2*: Compressor 2 side	□	●	□	ALT	High-pressure SW system operation	Compressor inverter
P05	P05	1*: Compressor 1 side 2*: Compressor 2 side	□	●	□	ALT	Phase missing detection/Power failure detection Inverter DC voltage trouble (compressor)	I/F
P07	P07	1*: Compressor 1 side 2*: Compressor 2 side ----- 04: Heat sink	□	●	□	ALT	Heat sink overheat trouble ----- Heat sink dew condensation trouble	Compressor inverter, I/F
P10	P10	Detected indoor unit address	●	□	□	ALT	Indoor unit overflow trouble	Indoor unit
P11	P11	—	●	□	□	ALT	Outdoor heat exchanger freezing trouble	I/F
P12	—	—	●	□	□	ALT	Indoor unit fan motor trouble	Indoor unit
P13	P13	—	●	□	□	ALT	Outdoor liquid back detection trouble	I/F
P14	P14	01: Outdoor unit valve is closed	●	□	□	ALT	Another refrigerant cycle protection	I/F

Check code			Wireless remote controller				Check code name	Judging device
Wired remote controller display	Outdoor unit 7-segment display		Sensor block display of receiving unit					
		Auxiliary code	Operation	Timer	Ready	Flash		
P15	P15	01: TS condition 02: TD condition	☐	●	☐	ALT	Gas leak detection	I/F
P16	P16	01: PMV5 02: PMV6 03: SV7	☐	●	☐	ALT	Injection circuit trouble	I/F
P17	P17	—	☐	●	☐	ALT	Discharge temp. TD2 trouble	I/F
P18	P18	—	☐	●	☐	ALT	Discharge temp. TD3 trouble	I/F
P19	P19	0#: 4-way valves 1#: 4-way valve1 2#: 4-way valve2 *Put in outdoor unit No. in [#] mark.	☐	●	☐	ALT	4-way valve inverse trouble	I/F
P20	P20	—	☐	●	☐	ALT	High-pressure protective operation	I/F
P22	P22	1*: Compressor 1 side 2*: Compressor 2 side	☐	●	☐	ALT	Outdoor unit fan inverter trouble	Fan inverter
P26	P26	1*: Compressor 1 side 2*: Compressor 2 side	☐	●	☐	ALT	IPM short protection trouble	Compressor inverter
P29	P29	1*: Compressor 1 side 2*: Compressor 2 side	☐	●	☐	ALT	Compressor position detective circuit system trouble	Compressor inverter
P31	—	—	☐	●	☐	ALT	Other indoor unit trouble (Group follower indoor unit trouble)	Indoor unit

• For details about check codes determined with an Interface P.C. board or an Inverter P.C. board, refer to the Installation Manual of the outdoor unit.

***1 Inverter quantity information**

(SMMS-e, SMMS-7, SMMS-u, SMMS ∞ , SHRM-A)

No.	Compressor Inverter		Fan Inverter		Trouble
	1	2	1	2	
01	○				Compressor 1
02		○			Compressor 2
03	○	○			Compressor 1 + Compressor 2
08			○		Fan1
09	○		○		Compressor 1 + Fan1
0A		○	○		Compressor 2 + Fan1
0B	○	○	○		Compressor 1 + Compressor 2 + Fan1
10				○	Fan2
11	○			○	Compressor 1 + Fan2
12		○		○	Compressor 2 + Fan2
13	○	○		○	Compressor 1 + Compressor 2 + Fan2
18			○	○	Fan1 + Fan2
19	○		○	○	Compressor 1 + Fan1 + Fan2
1A		○	○	○	Compressor 2 + Fan1 + Fan2
1B	○	○	○	○	All
○: Inverter trouble					

Trouble detected by central control device

Central control device indication	Check code		Wireless remote controller				Check code name	Judging device
	Outdoor unit 7-segment display		Sensor block display of receiving unit					
		Auxiliary code	Operation	Timer	Ready	Flash		
C05	—	—	—				Sending trouble in central control device	Central control device
C06	—	—	—				Receiving trouble in central control device	Central control device
C12	—	—	—				Batch alarm of general-purpose equipment control interface	General-purpose equipment I/F
P30 (L20)	Differs according to trouble contents of unit with occurrence of alarm		Group control follower unit trouble				<ul style="list-style-type: none"> • Duplication addresses of indoor units in central control device • With the combination of air conditioning system, the indoor unit may detect the check code of L20 	Central control device
	—	—	(L20 is displayed.)					
S01	—	—	—				Receiving trouble in central control device	Central control device

12 Specifications

Model	Sound pressure level (dBA)		Weight (kg) Main unit (Ceiling panel)
	Cooling	Heating	
MMU-UP0071WH-E	*	*	18 (10)
MMU-UP0091WH-E	*	*	18 (10)
MMU-UP0121WH-E	*	*	18 (10)
MMU-UP0151WH-E	*	*	18 (10)
MMU-UP0181WH-E	*	*	26 (14)
MMU-UP0241WH-E	*	*	26 (14)
MMU-UP0271WH-E	*	*	26 (14)
MMU-UP0301WH-E	*	*	26 (14)
MMU-UP0361WH-E	*	*	36 (14)
MMU-UP0481WH-E	*	*	36 (14)
MMU-UP0561WH-E	*	*	36 (14)

* Under 70 dBA

Product information of ecodesign requirements. (Regulation (EU) 2016/2281)
<http://ecodesign.toshiba-airconditioning.eu/en>

13 Notice code

- Notice code is a function only in TC2U-Link communication.
- When the outdoor or indoor unit detects its conditions requiring caution or maintenance, this function notices you to check your units with the spanner mark (Notice code mark) on the wired remote controller or central controller display.
- Even while the notice code mark is displayed, the air conditioner can operate normally.
- A maximum of 5 notice codes can be issued simultaneously in one system (line).

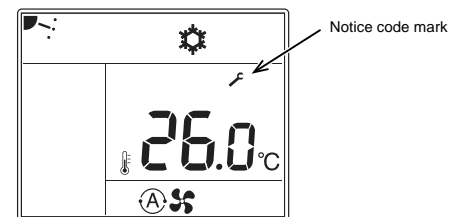

■ How to check Notice code No.

- 1 Stop the operation of the air conditioner and push the Menu button and OFF timer button at the same time for 10 seconds or more.
- 2 The unit number of the indoor unit is displayed at the bottom left of the screen. Change it with the [▽][△] setting button and push the OFF timer button to confirm.
- 3 The history number is displayed in the center of the screen, and the Notice code No. is displayed in the lower left. [▽][△] You can switch the history with the setting button (a maximum of 5 notice codes).
- 4 Push the ON / OFF button to return to the operation stop screen.

■ Notice code list

Notice code No.	Item	Content
203	Flow Selector unit battery dead	The battery kit connected to the Flow Selector unit has reached the end of its life.
204	Leak detector life advance display	The leak detector will soon reach the end of its life.

Declaration of Conformity

Manufacturer: Carrier Japan Corporation
336 Tadehara, Fuji-shi, Shizuoka-ken 416-8521 JAPAN

TCF holder: Carrier RLC Europe S.A.S
Immeuble Le Cristalia 3 rue Joseph Monier
92500 Rueil-Malmaison FRANCE

Hereby declares that the machinery described below:

Generic Denomination: Air Conditioner

Model / type: MMU-UP0071WH-E, MMU-UP0091WH-E, MMU-UP0121WH-E,
MMU-UP0151WH-E, MMU-UP0181WH-E, MMU-UP0241WH-E,
MMU-UP0271WH-E, MMU-UP0301WH-E, MMU-UP0361WH-E,
MMU-UP0481WH-E, MMU-UP0561WH-E

Commercial name: Super Modular Multi System Air Conditioner
Super Heat Recovery Multi System Air Conditioner
Mini-Super Modular Multi System Air Conditioner (MiNi-SMMS series)

Complies with the provisions of the “Machinery Directive 2006 / 42 / EC” and the regulations transposing into national law

Name: Masaya Seito
Position: Senior Manager, Quality Assurance Dept.
Date: 1 May, 2024
Place Issued: Japan

NOTE

This declaration becomes invalid if technical or operational modifications are introduced without the manufacturer's consent.

Declaration of Conformity

Manufacturer: Carrier Japan Corporation
336 Tadehara, Fuji-shi, Shizuoka-ken 416-8521 JAPAN

TCF holder: Carrier Solutions UK Ltd.
Porsham Close, Belliver Industrial Estate,
PLYMOUTH, Devon,
PL6 7DB, United Kingdom

Hereby declares that the machinery described below:

Generic Denomination: Air Conditioner

Model / type: MMU-UP0071WH-E, MMU-UP0091WH-E, MMU-UP0121WH-E,
MMU-UP0151WH-E, MMU-UP0181WH-E, MMU-UP0241WH-E,
MMU-UP0271WH-E, MMU-UP0301WH-E, MMU-UP0361WH-E,
MMU-UP0481WH-E, MMU-UP0561WH-E

Commercial name: Super Modular Multi System Air Conditioner
Super Heat Recovery Multi System Air Conditioner
Mini-Super Modular Multi System Air Conditioner (MiNi-SMMS series)

Complies with the provisions of the Supply of Machinery (Safety) Regulations 2008

Name: Masaya Seito
Position: Senior Manager, Quality Assurance Dept.
Date: 1 May, 2024
Place Issued: Japan

NOTE

This declaration becomes invalid if technical or operational modifications are introduced without the manufacturer's consent.

WARNINGS ON REFRIGERANT LEAKAGE

Check of Concentration Limit

The room in which the air conditioner is to be installed requires a design that in the event of refrigerant gas leaking out, its concentration will not exceed a set limit.

Refrigerant R32

The refrigerant R32 which is used in the air conditioner is mildly flammable. In Europe and areas where IEC standards apply, EN/IEC 60335-2-40 is the applicable standard. The refrigerant R32 does not have the toxicity of ammonia, and is not restricted by laws to be imposed which protect the ozone layer. If this appliance is connected with the outdoor unit containing R32 refrigerant, refer to the Installation and Owner's Manual attached to the outdoor unit.

Refrigerant R410A

The refrigerant R410A which is used in the air conditioner is safe, without the toxicity or combustibility of ammonia, and is not restricted by laws to be imposed which protect the ozone layer. However, since it contains more than air, it poses the risk of suffocation if its concentration should rise excessively. Suffocation from leakage of R410A is almost non-existent. With the recent increase in the number of high concentration buildings, however, the installation of multi air conditioner systems is on the increase because of the need for effective use of floor space, individual control, energy conservation by curtailing heat and carrying power etc.

Most importantly, the multi air conditioner system is able to replenish a large amount of refrigerant compared with conventional individual air conditioners. If a single unit of the multi conditioner system is to be installed in a small room, select a suitable model and installation procedure so that if the refrigerant accidentally leaks out, its concentration does not reach the limit (and in the event of an emergency, measures can be made before injury can occur).

In a room where the concentration may exceed the limit, create an opening with adjacent rooms, or install mechanical ventilation combined with a gas leak detection device.

The concentration is as given below.

$$\frac{\text{Total amount of refrigerant (kg)}}{\text{Min. volume of the indoor unit installed room (m}^3\text{)}} \leq \text{Concentration limit (kg/m}^3\text{)}$$

Refrigerant Concentration Limit shall be in accordance with local regulations.

▼ NOTE 1

If there are 2 or more refrigerating systems in a single refrigerating device, the amounts of refrigerant should be as charged in each independent device.

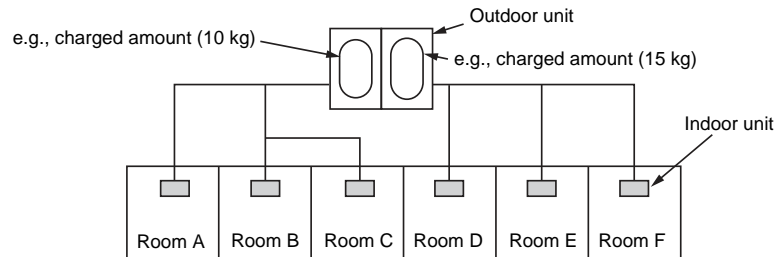

For the amount of charge in this example:

The possible amount of leaked refrigerant gas in rooms A, B and C is 10 kg.

The possible amount of leaked refrigerant gas in rooms D, E and F is 15 kg.

■ Important

▼ NOTE 2

The standards for minimum room volume are as follows.

- 1) No partition (shaded portion)

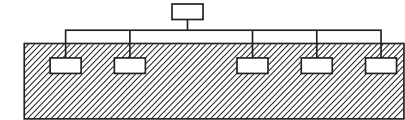

- 2) When there is an effective opening with the adjacent room for ventilation of leaking refrigerant gas (opening without a door, or an opening 0.15% or larger than the respective floor spaces at the top or bottom of the door).

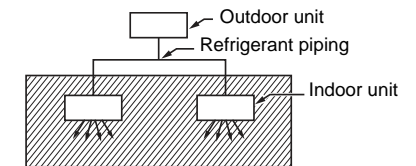

- 3) If an indoor unit is installed in each partitioned room and the refrigerant piping is interconnected, the smallest room of course becomes the object. But when a mechanical ventilation is installed interlocked with a gas leakage detector in the smallest room where the density limit is exceeded, the volume of the next smallest room becomes the object.

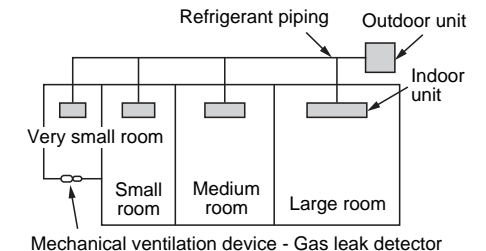

Confirmation of indoor unit setup

Prior to delivery to the customer, check the address and setup of the indoor unit, which has been installed in this time and fill the check sheet (Table below). Data of four units can be entered in this check sheet. Copy this sheet according to the No. of the indoor units. If the installed system is a group control system, use this sheet by entering each line system into each Installation Manual attached to the other indoor units.

REQUIREMENT

This check sheet is required for maintenance after installation. Fill this sheet and then pass this Installation Manual to the customers.

Indoor unit setup check sheet

Indoor unit		Indoor unit		Indoor unit		Indoor unit		
Room name	Room name	Room name	Room name	Room name	Room name	Room name	Room name	
Model	Model	Model	Model	Model	Model	Model	Model	
Check indoor unit address. (For check method, refer to Service Manual of outdoor unit.) *In case of a single system, it is unnecessary to enter the indoor address. (CODE NO.: Line [12], Indoor [13], Group [14], Central control [03])								
Line	Indoor	Group	Line	Indoor	Group	Line	Indoor	Group
Central control address		Central control address		Central control address		Central control address		
Various setup		Various setup		Various setup		Various setup		
Have you changed high ceiling setup? If not, fill check mark [x] in [NO CHANGE], and fill check mark [x] in [ITEM] if changed, respectively. (For check method, refer to APPLCABLE CONTROLS in this manual.) * In case of replacement of jumper blocks on indoor microcomputer P.C. board, setup is automatically changed.								
High ceiling setup (CODE NO. [5d]) <input type="checkbox"/> NO CHANGE <input type="checkbox"/> STANDARD <input type="checkbox"/> HIGH CEILING 1 <input type="checkbox"/> HIGH CEILING 3		High ceiling setup (CODE NO. [5d]) <input type="checkbox"/> NO CHANGE <input type="checkbox"/> STANDARD <input type="checkbox"/> HIGH CEILING 1 <input type="checkbox"/> HIGH CEILING 3		High ceiling setup (CODE NO. [5d]) <input type="checkbox"/> NO CHANGE <input type="checkbox"/> STANDARD <input type="checkbox"/> HIGH CEILING 1 <input type="checkbox"/> HIGH CEILING 3		High ceiling setup (CODE NO. [5d]) <input type="checkbox"/> NO CHANGE <input type="checkbox"/> STANDARD <input type="checkbox"/> HIGH CEILING 1 <input type="checkbox"/> HIGH CEILING 3		
Have you changed lighting time of filter sign? If not, fill check mark [x] in [NO CHANGE], and fill check mark [x] in [ITEM] if changed, respectively. (For check method, refer to APPLCABLE CONTROLS in this manual.)								
Filter sign lighting time (CODE NO. [01]) <input type="checkbox"/> NO CHANGE <input type="checkbox"/> NONE <input type="checkbox"/> 150 H <input type="checkbox"/> 2500 H <input type="checkbox"/> 5000 H <input type="checkbox"/> 10000 H		Filter sign lighting time (CODE NO. [01]) <input type="checkbox"/> NO CHANGE <input type="checkbox"/> NONE <input type="checkbox"/> 150 H <input type="checkbox"/> 2500 H <input type="checkbox"/> 5000 H <input type="checkbox"/> 10000 H		Filter sign lighting time (CODE NO. [01]) <input type="checkbox"/> NO CHANGE <input type="checkbox"/> NONE <input type="checkbox"/> 150 H <input type="checkbox"/> 2500 H <input type="checkbox"/> 5000 H <input type="checkbox"/> 10000 H		Filter sign lighting time (CODE NO. [01]) <input type="checkbox"/> NO CHANGE <input type="checkbox"/> NONE <input type="checkbox"/> 150 H <input type="checkbox"/> 2500 H <input type="checkbox"/> 5000 H <input type="checkbox"/> 10000 H		
Have you changed detected temp. shift value? If not, fill check mark [x] in [NO CHANGE], and fill check mark [x] in [ITEM] if changed, respectively. (For check method, refer to APPLCABLE CONTROLS in this manual.)								
Detected temp. shift value setup (CODE NO. [06]) <input type="checkbox"/> NO CHANGE <input type="checkbox"/> NO SHIFT <input type="checkbox"/> +1°C <input type="checkbox"/> +2°C <input type="checkbox"/> +3°C <input type="checkbox"/> +4°C <input type="checkbox"/> +5°C <input type="checkbox"/> +6°C		Detected temp. shift value setup (CODE NO. [06]) <input type="checkbox"/> NO CHANGE <input type="checkbox"/> NO SHIFT <input type="checkbox"/> +1°C <input type="checkbox"/> +2°C <input type="checkbox"/> +3°C <input type="checkbox"/> +4°C <input type="checkbox"/> +5°C <input type="checkbox"/> +6°C		Detected temp. shift value setup (CODE NO. [06]) <input type="checkbox"/> NO CHANGE <input type="checkbox"/> NO SHIFT <input type="checkbox"/> +1°C <input type="checkbox"/> +2°C <input type="checkbox"/> +3°C <input type="checkbox"/> +4°C <input type="checkbox"/> +5°C <input type="checkbox"/> +6°C		Detected temp. shift value setup (CODE NO. [06]) <input type="checkbox"/> NO CHANGE <input type="checkbox"/> NO SHIFT <input type="checkbox"/> +1°C <input type="checkbox"/> +2°C <input type="checkbox"/> +3°C <input type="checkbox"/> +4°C <input type="checkbox"/> +5°C <input type="checkbox"/> +6°C		
Remote controller sensor (CODE NO. [32]) <input type="checkbox"/> NO CHANGE <input type="checkbox"/> NOT IN USE <input type="checkbox"/> IN USE		Remote controller sensor (CODE NO. [32]) <input type="checkbox"/> NO CHANGE <input type="checkbox"/> NOT IN USE <input type="checkbox"/> IN USE		Remote controller sensor (CODE NO. [32]) <input type="checkbox"/> NO CHANGE <input type="checkbox"/> NOT IN USE <input type="checkbox"/> IN USE		Remote controller sensor (CODE NO. [32]) <input type="checkbox"/> NO CHANGE <input type="checkbox"/> NOT IN USE <input type="checkbox"/> IN USE		
Incorporation of parts sold separately		Incorporation of parts sold separately		Incorporation of parts sold separately		Incorporation of parts sold separately		
Have you incorporated the following parts sold separately? If incorporated, fill check mark [x] in each [ITEM]. (When incorporating, the setup change is necessary in some cases. For setup change method, refer to Installation Manual attached to each part sold separately.)								
<input type="checkbox"/> Others ()		<input type="checkbox"/> Others ()		<input type="checkbox"/> Others ()		<input type="checkbox"/> Others ()		

Carrier Japan Corporation

336 TADEHARA, FUJI-SHI, SHIZUOKA-KEN 416-8521 JAPAN

**EB99840701-2
(DH91307203)**