

AQUAEDGE®

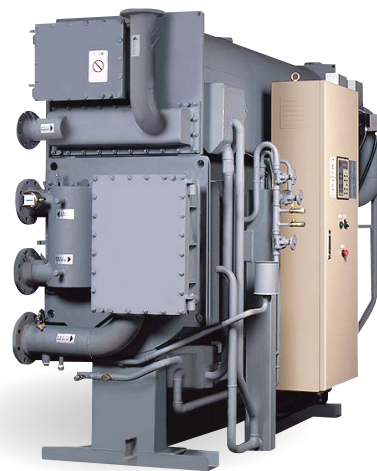

16TJ

Single-effect steam-fired
absorption chillers
Super absorption

Nominal cooling capacity:
350 - 2500 kW

Complete range 350 to 2500 kW
HFC-refrigerant free
Steam supply pressure 50 to 100
kPa

The Carrier Corporation has more than 100 years experience in providing HVAC systems and equipment around the world and offers a complete product solutions for many different type of applications: From residential to industrial.

For all cases where power grid is not available on site or either not extensively developed, or where thermal energy sources (water or steam) are available on site, Carrier offers a complete range of absorption chillers.



Physical data

Single effect steam-fired absorption chillers

16TJ		11	12	13	14	21	22	23	24
Cooling capacity	kW	352	422	527	633	738	844	985	1125
Chilled water system^①									
Flow rate	l/s	15,1	18,2	22,7	27,3	31,7	36,4	42,5	48,3
Pressure drops	kPa	50	51	64	67	60	64	42	45
Connection (ANSI)	in	4	4	4	4	5	5	6	6
Retention volume	m ³	0,12	0,13	0,15	0,17	0,22	0,25	0,29	0,31
Cooling water system^①									
Flow rate	l/s	22,7	27,3	34,2	40,8	47,8	54,4	63,6	72,8
Pressure drops	kPa	34	37	32	36	32	35	65	70
Connection (ANSI)	in	5	5	5	5	6	6	8	8
Retention volume	m ³	0,33	0,37	0,41	0,45	0,58	0,63	0,69	0,76
Steam system									
Consumption	kg/h	780	940	1170	1410	1640	1880	2190	2500
Steam inlet (ANSI)	in	5	5	5	5	6	6	8	8
Drain outlet (ANSI)	in	1-1/2	1-1/2	1-1/2	1-1/2	1-1/2	1-1/2	1-1/2	1-1/2
Control valve	in	2	2	2-1/2	2-1/2	2-1/2	3	3	4
Shutoff valve	in	2	2	2-1/2	2-1/2	2-1/2	3	3	4
Dimensions									
Length	mm	2690	2690	3690	3690	3790	3790	4850	4850
Height	mm	2200	2200	2200	2200	2350	2350	2370	2370
Width	mm	1400	1400	1400	1400	1560	1560	1560	1560
Tube removal space	mm	2400	2400	3400	3400	3400	3400	4500	4500
Weight									
Operating weight	kg	4000	4300	5100	5400	6700	6900	7900	8300
Max shipping weight ^②	kg	3500	3700	4500	4700	5800	6000	6900	7200
Power supply	V-ph-Hz	400-3-50							
Apparent power	kVA	4,0	4,0	4,0	4,0	5,8	5,8	5,9	5,9
Total electric current	A	6,1	6,1	6,1	6,1	8,8	8,8	8,9	8,9
Absorbent pump, power input	kW	1,1	1,1	1,1	1,1	2,2	2,2	2,2	2,2
Absorbent pump, electric current	A	2,8	2,8	2,8	2,8	5,5	5,5	5,5	5,5
Refrigerant pump, power input	kW	0,2	0,2	0,2	0,2	0,2	0,2	0,3	0,3
Refrigerant pump, electric current	A	1,3	1,3	1,3	1,3	1,3	1,3	1,4	1,4
Purge pump, power input	kW	0,4	0,4	0,4	0,4	0,4	0,4	0,4	0,4
Purge pump, electric current	A	1,1	1,1	1,1	1,1	1,1	1,1	1,1	1,1
PD cell heater	kW	0,038	0,038	0,038	0,038	0,038	0,038	0,038	0,038
Control circuit	kW	0,3	0,3	0,3	0,3	0,3	0,3	0,3	0,3

① In accordance with ARI 560 - 2000
 12.2 / 6.7 °C (fouling factor = 0.0176 m² K/kW)
 29.4 / 38.4 °C (fouling factor = 0.044 m² K/kW)
 Saturated steam 100 kPa

② All sizes shipped as one-piece

Notes: These performance data are provided to support early design activity. For selection outside ARI operating conditions contact Carrier.

Physical data

16TJ		31	32	41	42	51	52	53
Cooling capacity	kW	1266	1407	1582	1758	1969	2215	2461
Chilled water system^①								
Flow rate	l/s	54,4	60,6	68,1	75,8	84,7	95,3	106,1
Pressure drops	kPa	48	51	44	39	35	47	61
Connection (ANSI)	in	6	6	8	8	8	8	8
Retention volume	m ³	0,35	0,38	0,49	0,56	0,7	0,77	0,83
Cooling water system^①								
Flow rate	l/s	81,7	90,8	102,2	113,6	127,2	143,1	158,9
Pressure drops	kPa	54	57	59	63	39	52	68
Connection (ANSI)	in	8	8	10	10	12	12	12
Retention volume	m ³	0,98	1,05	1,31	1,41	1,98	2,13	2,28
Steam system								
Consumption	kg/h	2810	3120	3510	3900	4370	4920	5460
Steam inlet (ANSI)	in	8	8	8	8	10	10	10
Drain outlet (ANSI)	in	2	2	2-1/2	2-1/2	2-1/2	2-1/2	2-1/2
Control valve	in	4	4	4	4	4	5	5
Shutoff valve	in	4	4	4	4	4	5	5
Dimensions								
Length	mm	4940	4940	4990	4990	5060	5600	6100
Height	mm	2610	2610	2860	2860	3210	3210	3210
Width	mm	1630	1630	1700	1700	1990	1990	1990
Tube removal space	mm	4500	4500	4500	4500	4600	5200	5700
Weight								
Operating weight	kg	10300	10600	12500	12800	17500	18900	20200
Max shipping weight ^②	kg	8900	9100	10700	10900	14800	16000	17100
Power supply	V-ph-Hz	400-3-50						
Apparent power	kVA	7,3	7,3	7,3	7,3	7,3	7,3	7,3
Total electric current	A	10,9	10,9	10,9	10,9	10,9	10,9	10,9
Absorbent pump, power input	kW	3	3	3	3	3	3	3
Absorbent pump, electric current	A	7,5	7,5	7,5	7,5	7,5	7,5	7,5
Refrigerant pump, power input	kW	0,3	0,3	0,3	0,3	0,3	0,3	0,3
Refrigerant pump, electric current	A	1,4	1,4	1,4	1,4	1,4	1,4	1,4
Purge pump, power input	kW	0,4	0,4	0,4	0,4	0,4	0,4	0,4
Purge pump, electric current	A	1,1	1,1	1,1	1,1	1,1	1,1	1,1
PD cell heater	kW	0,038	0,038	0,038	0,038	0,038	0,038	0,038
Control circuit	kW	0,3	0,3	0,3	0,3	0,3	0,3	0,3

① In accordance with ARI 560 - 2000
 12.2 / 6.7 °C (fouling factor = 0.0176 m² K/kW)
 29.4 / 38.4 °C (fouling factor = 0.044 m² K/kW)
 Saturated steam 100 kPa

② All sizes shipped as one-piece

Notes: These performance data are provided to support early design activity. For selection outside ARI operating conditions contact Carrier.

Nomenclature

16TJ - 11

Capacity code

Unit type: Single-effect, steam-fired absorption chillers

Component identification

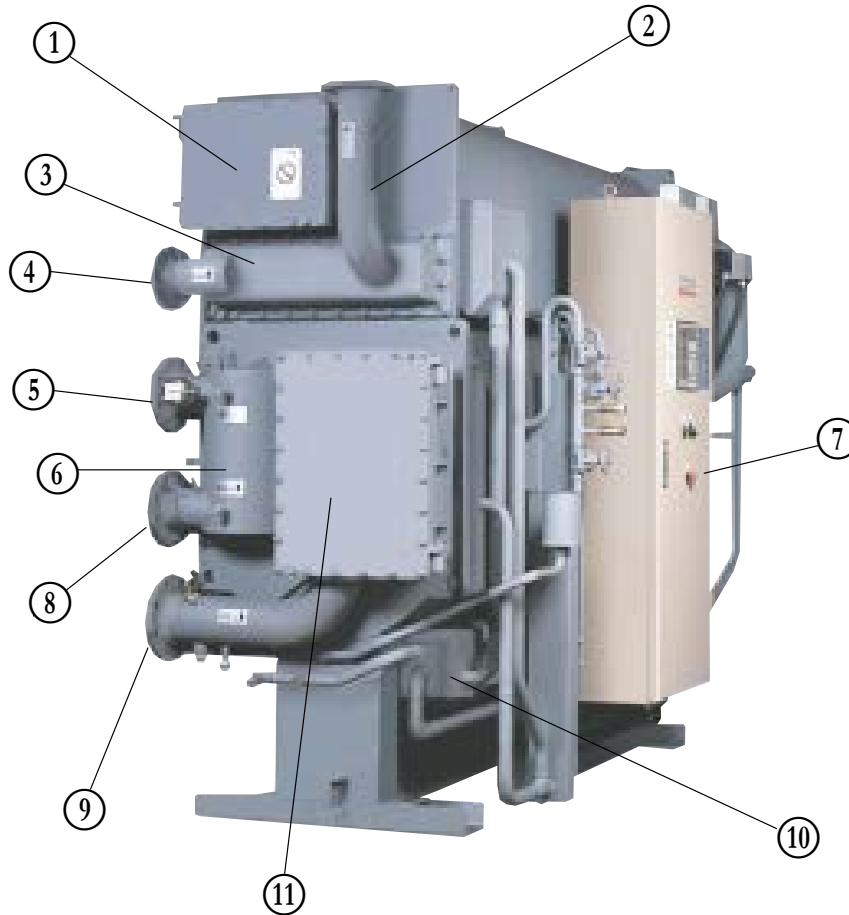

Legend

- ① Condenser
- ② Steam inlet
- ③ Generator
- ④ Chilled-water outlet
- ⑤ Control panel
- ⑥ Evaporator
- ⑦ Chilled-water inlet
- ⑧ Cooling water inlet
- ⑨ Heat exchanger
- ⑩ Heat reclaimer
- ⑪ Absorber

Scope of supply

1. Standards met

The units comply with the following standards:

- ARI 560-2000.
- 2006/42/EC (machine directive).
- 2006/95/EC (low-voltage directive).
- 2004/108/EC (electromagnetic compatibility directive).
- 97/23/EC (pressure equipment directive).

2. Absorption chiller, comprising

1. Lower shell:
 - Evaporator and refrigerant dispersion tray.
 - Absorber and absorbent dispersion tray with eliminators.
 - Bases.
2. Upper shell:
 - Generator with eliminators.
 - Condenser with eliminators.
 - Rupture disk.
3. Heat exchangers with refrigerant drain heat reclaimers.
4. Pumps:
 - Absorbent pump with isolating valves.
 - Refrigerant pump with isolating valves.
 - Purge pump.
5. Purge unit:
 - Purge tank with ejector device.
 - Diaphragm valves and piping with liquid trap.
 - Pressure sensor.
 - Palladium cell with heater.
6. Control panel:
 - Controller with data display.
 - LEDs and operation buttons.
 - Inverter for absorbent pump (option)
 - Circuit breaker.
 - Transformer.
 - Relays and terminal blocks.
 - Purge pump operation switch.
7. Locally mounted parts:
 - Temperature sensors.
 - Chilled-water flow switch.
8. Interconnecting piping and wiring:
 - Refrigerant and absorbent piping.
 - Internal power and control wiring.
9. Initial charge:
 - Absorbent (lithium bromide).
 - Refrigerant (water).
 - Inhibitor (lithium molybdate).
10. Painting:
 - Main unit: Rust-preventive paint.
 - Control panel: Finish paint.
11. Accessories:
 - Operation manual.
 - Washer (for fixing foundation bolts).
 - Gasket and sealant for rupture disk.
 - Purge pump oil.
 - Matching flanges, gaskets, bolts and nuts.

3. Factory test

1. Check of external dimensions.
2. Hydraulic pressure test of water headers Test pressure is 1.5 times of maximum working pressure.
3. Vacuum-side leak test.
4. Electric insulation resistance test.
5. Dielectric breakdown test.
6. Function test of electric circuit and safety devices.

4. Scope of supply of the purchaser

1. Building and foundations.
2. External chilled water, cooling water and steam piping work including various safety valves, isolation valves, mating flanges, gaskets, bolts and nuts, etc.
3. External wiring and piping for the chillers including necessary parts.
4. Insulation for the chillers including necessary parts.
5. Finish painting of the chillers (if needed).
6. Cooling water entering temperature control device.
7. Cooling water treatment device.
8. Various temperature/pressure gauges for steam and water lines.
9. Cooling tower(s), chilled-water pump(s) and steam control valve and steam shut-off valve.
10. Electric power supply (as specified).
11. Supply of chilled water, cooling water, steam and air[ⓐ] at rated conditions.
12. Maintenance of the chiller.
13. Necessary tools, labour and materials for installation and site test operation.
14. Any other item not specifically mentioned in the scope of supply.

ⓐ If pneumatic steam valve control is used.

Scope of order

Item	Standard	Option
Chilled water		
Temperature	Entering: 12,2 °C, leaving: 5 °C through 12 °C Leaving: 6,7 °C, temperature difference 3 K through 10 K	
Flow rate	0,043 l/s x kW - Changes depending on chilled water temperature difference (min 50%)	
Max. working pressure	1034 kPa	1540 kPa, 2068 kPa
Hydraulic test pressure Fouling factor Tube material Water quality Structure of water header Manufacturing standard of water header	Max.working pressure x 1,5 0,018 m ² K/kW Max. 0,18 m ² K/kW Copper tube Refer to JRA-GL02E-1994 Removable type and epoxy treated Flanged ANSI	Max working pressure x 1,5 Cu Ni tube No option No option No option
Cooling water		
Temperature	Entering: 29,4 °C Leaving: 38,4 °C, entering: 20 °C through 33 °C	
Flow rate	0,065 l/s per kW. Within the water flow rate range of each model	
Max. working pressure Hydraulic test pressure Fouling factor Tube material Water quality Structure of water header Manufacturing standard of water header	1034 kPa Max. working pressure x 1,5 0,044 m ² K/kW. Max. 0,18 m ² K/kW Copper tube Refer to JRA-GL02E-1994 Hinged type and epoxy treated Flanges ANSI	1540 kPa, 2068 kPa Cu Ni tube No option No option No option
Steam		
Supply pressure Specific steam consumption	100 kPa, 50 kPa through 100 kPa, max. 5 K superheat 2,22 kg/h/kW. Changes depend on the specifications.	
Max. working pressure Hydraulic test pressure Tube material Steam quality Manufacturing standard of water header	146 kPa Max. working pressure x 1,5 9/1 Copper nickel tube Refer to JIS-B-8223 Flanged ANSI	No option No option No option No option No option
Electricity		
Power supply	400 V - 3 phase - 50Hz (Voltage control within ±10%, frequency control within ±5%)	Contact the Carrier representative
Shipment	One section	Multi-shipment
Control		
Safety functions	Refrigerant temperature Chilled water freeze protection Chilled water flow switch Cooling water temperature HT generator temperature HT generator pressure HT generator solution level Crystallisation protection Motor protection	Cooling water flow switch
Capacity control	Digital PID control by chilled-water temperature	Inverter control of #1 absorbent pump
Parts	Selected by Carrier	No option

Scope of order

Item	Standard	Option
Control panel		
Painting	Munsell 5Y-7/1	No option
Indication lights	Operation Stop Alarm	No option No option No option
Display	LED	No option
External terminals (volt-free normally open contact)	Operation indication Stop indication Alarm indication Feedback indication Cooling mode indication	No option
Structure Parts	Indoor type Selected by Carrier	No option No option
Electrical wiring and piping	Wire: 600 V polyvinyl grade (chloride-insulated wires) Pipe: Plicatube (flexible metal conduits)	No option No option
Insulation condition		
Place Ambient temperature Ambient humidity	Indoor 5 °C through 40 °C Relative humidity: Max. 90 % at 45 °C	No option No option No option
Atmosphere	Be sure the following are not present: - Corrosive gas - Explosive gas - Poisonous gas	No option

Features and advantages

- The Carrier 16TJ single-effect absorption chillers are designed for cooling applications where low-pressure steam is available as waste heat.
- They can tie into district steam systems.
- Carrier absorption chillers allow diversification of critical cooling requirements. Critical cooling loads are met with minimal electrical power input.
- They allow smaller emergency generators compared to an electrical driven chiller.
- The units are ozone-safe and CFC-free. Cooling requirements are met without chlorine-based refrigerants.
- They reduce the contribution to global warming and minimise the global impact by greatly reducing electricity consumption and production of greenhouse gases.
- The solution inhibitor has no impact on the environment.
- An absorption chiller does not utilise mechanical moving parts, and this leads to quiet, vibration-free operation.
- The use of high-efficiency heat transfer surfaces has reduced the space required for installation of the absorption chiller, resulting in a smaller footprint.

Controls

Expert self-diagnosis function

- The expert function is provided to monitor operating conditions, predict chiller information and maintain stable operation.

Predictive maintenance information

Graph 1 - Fouling of heat transfer tubes in cooling water system

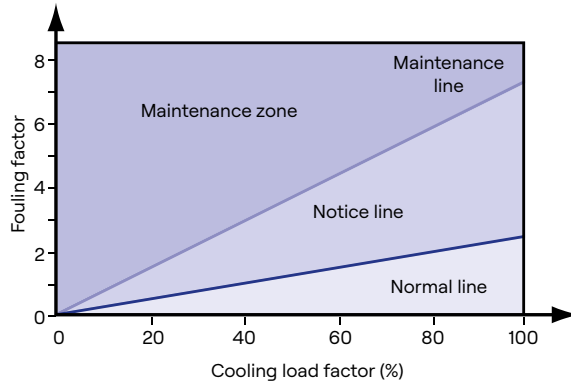

Graph 2 - Trend of absorbent concentration

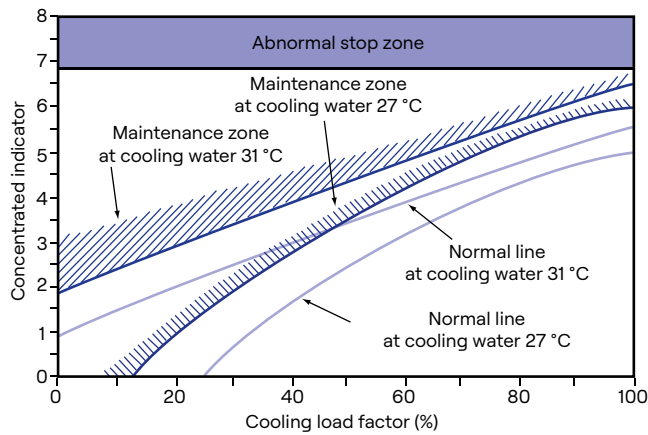

Graph 3 - Vacuum condition monitoring

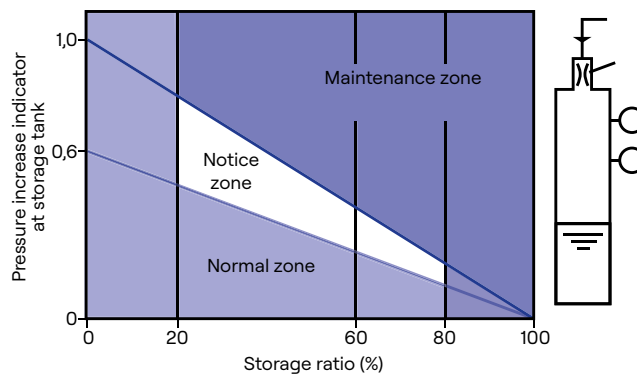

Legend

- ① Storage tank
- ② Diluted solution
- ③ Purge nozzle
- ④ Pd cell
- ⑤ Pressure sensor

Controls

Carrier control system

- The Carrier control system surpasses other proportional only control systems available today. The digital PID (proportional plus integral plus derivative) control maximises unit performance by maintaining a ± 0.5 K variance in leaving chilled-water temperature from the set-point. Proportional controls can typically only maintain a ± 1 K variance from the set-point. The controller's innovative design also incorporates the ability to start and stop the system chilled and cooling water pumps. During shutdown these pumps are sequenced to ensure a complete dilution cycle.
- The leaving chilled-water temperature is measured every five seconds and steam input is changed according to the gradient of the leaving chilled-water temperature curve. System temperatures, set-points, and operational records are displayed along with indicator lights for the chiller and pumps.
- The Carrier control system offers its users selfdiagnostics by constantly monitoring the chiller status and will automatically shut the chiller down if a fault occurs. The cause of shutdown will be retained in the memory and can be displayed for immediate operator review. The controller's memory will also retain and display the cause of the last three system fault conditions. This method of retaining fault conditions is extremely useful for maintaining an accurate record of unit performance and fault history.

Display and control board
Figure 2 - Indication lights

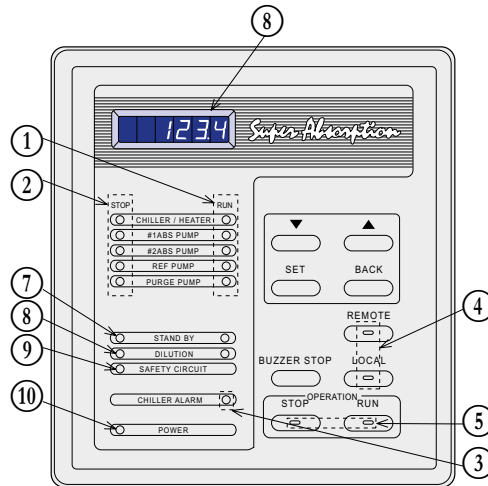

Legend

Name

- ① Operation indication light
- ② Stop indication light
- ③ Alarm indication light
- ④ Remote/local select button with LED
- ⑤ Operation select button with LED
- ⑥ Data display
- ⑦ Stand-by indication light
- ⑧ Dilution indication light
- ⑨ Safety circuit indication light
- ⑩ Power indication light
- GL. Purge indication light
- 43P. Purge pump on-off switch
- 43ES. Emergency stop switch

LED colour

- Green
- Orange
- Red
- Green
- Green
- 7 segment LED (red)
- Green
- Green
- Green
- Orange
- Green

Controls

Fast digital PID control

The introduction of new digital PID control stabilises the chilled water temperature with high accuracy. It quickly responds to the load fluctuation and supplies stable chilled water temperature. It is suitable for air-conditioning intelligent buildings which require sophisticated control.

Saving energy with the inverter (option)

Balancing the load and flow rate with the absorbent pump's inverter control enables efficient and energy-saving operation. As a result, it reduces input energy and electric power consumption. Running cost is decreased by 5% compared to non-inverter control.

Graph 4 - Running cost curve

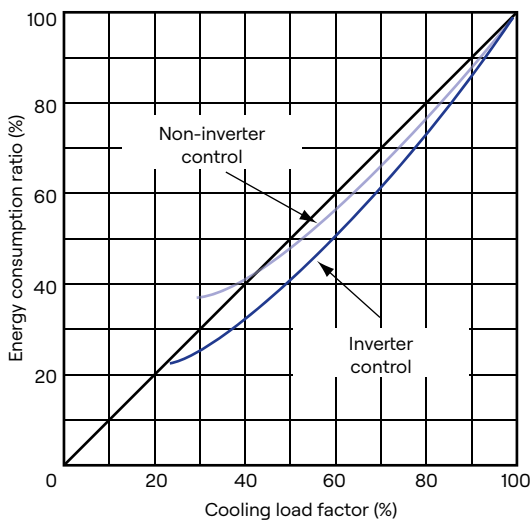

Notes:

- 1. Chilled-water leaving temperature 7 °C constant
- 2. Cooling water entering temperature:

Load factor (%)	Temperature (°C)
100	32
50	27
30	25

Purge system

- The high-performance purge system maintains the required operating pressure, preserves chiller performance characteristics, minimises chiller maintenance to one purge operation per season (for year-round operation).

Steam valve opening control

- At the start-up, the opening angle of the steam control valve is controlled in three stages, reducing the amount of steam and the time needed to reach the desired level, compared with the previous model.
- Adjusting the opening speed of the steam control valve at the second and third stage, it is possible to set up the most suitable conditions for the site auxiliary equipment.

Graph 5 - Steam valve opening control

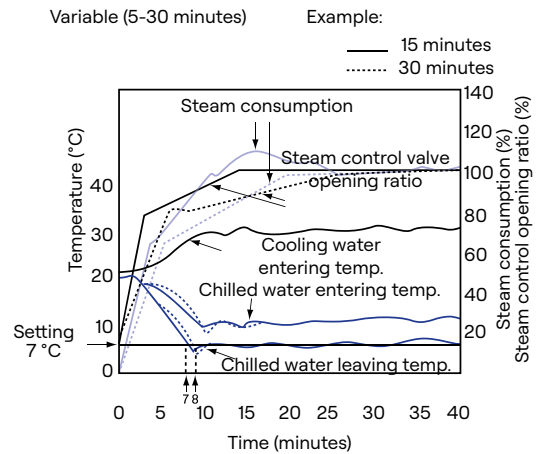

Expansion of safe operating zone

- This ensures quick response to rapid changes and maintains stable operation.
- The safe operating zone is between 19 °C and 34 °C cooling water temperature (for a nominal cooling water entering temperature of 32 °C).

Graph 6 - Safe operating zone chart

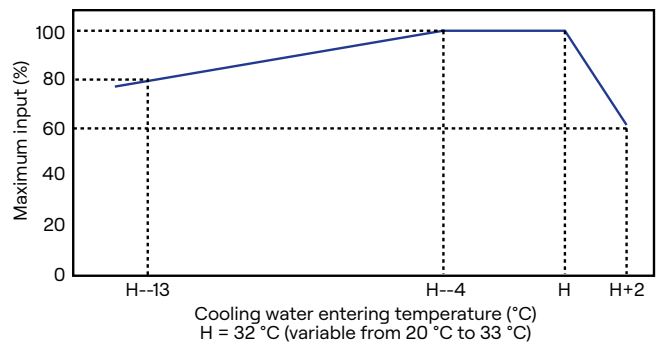

Crystallisation protection

- A microprocessor monitors the absorbent concentration. Steam supply is stopped, and the unit is returned to normal operation, when the concentration is over a certain limit, to prevent the crystallisation of absorbent.

Foundation dimensions, mm

Figure 3 - 16TJ-11 through 16TJ-42

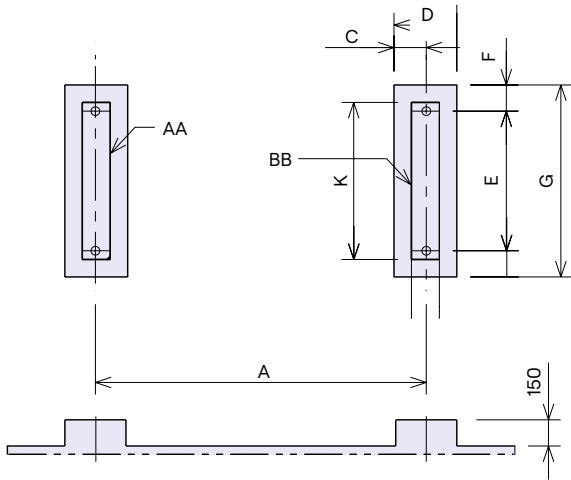

Figure 5 - 16TJ-51 through 16TJ-53

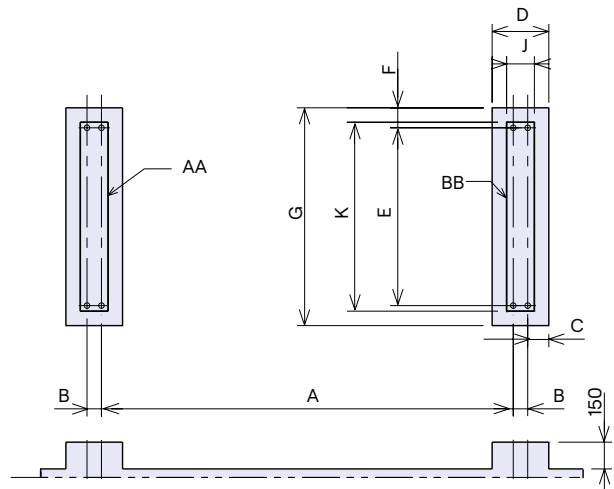
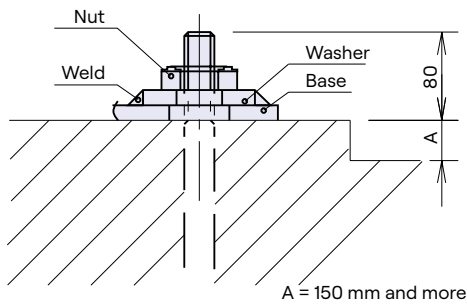

Figure 4 - Details of weld



Notes:

1. The machine base has $\varnothing 50$ -mm hole for the anchor bolt.
2. The anchor bolt should be fixed as shown in the detail drawing. Washer should be welded to the base (see Fig. 4)
3. There should be a drain channel around the foundation.
4. The floor surface should be made waterproof to facilitate maintenance work.
5. The surface of the foundation should be made flat.
6. Anchor bolts and nuts are to be supplied by customer.

Dimensional data

16TJ	Weight, kg			Dimensions, mm								
	AA + BB	AA	BB	A	B	C	D	E	F	G	J	K
11	3800	1900	1900	1890	--	175	360	800	150	1100	160	900
12	4000	2000	2000	1890	--	175	360	800	150	1100	160	900
13	4900	2450	2450	2916	--	175	360	800	150	1100	160	900
14	5100	2550	2550	2916	--	175	360	800	150	1100	160	900
21	6200	3100	3100	2866	--	200	400	1000	150	1300	200	1100
22	6500	3250	3250	2866	--	200	400	1000	150	1300	200	1100
23	7600	3800	3800	3886	--	200	400	1000	150	1300	200	1100
24	8000	4000	4000	3886	--	200	400	1000	150	1300	200	1100
31	9800	4900	4900	3836	--	225	450	1100	150	1400	250	1200
32	10 200	5100	5100	3836	--	225	450	1100	150	1400	250	1200
41	11 800	5900	5900	3836	--	225	450	1150	150	1450	250	1250
42	12 300	6150	6150	3836	--	225	450	1150	150	1450	250	1250
51	16 900	8450	8450	3706	130	190	510	1600	180	1960	250	1700
52	18 300	9150	9150	4248	130	190	510	1600	180	1960	250	1700
53	19 600	9800	9800	4746	130	190	510	1600	180	1960	250	1700